

J. BALDERMANN.
Lime and Other Kilns.

No. 210,834.

Patented Dec. 17, 1878.

Fig. 5.

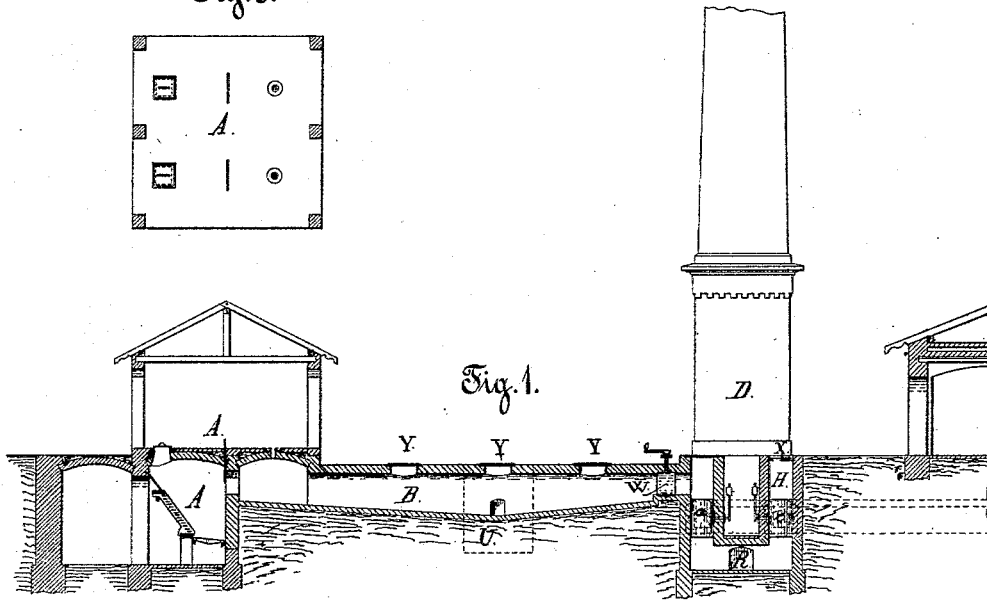
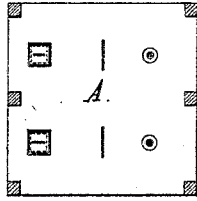

Fig. 1.

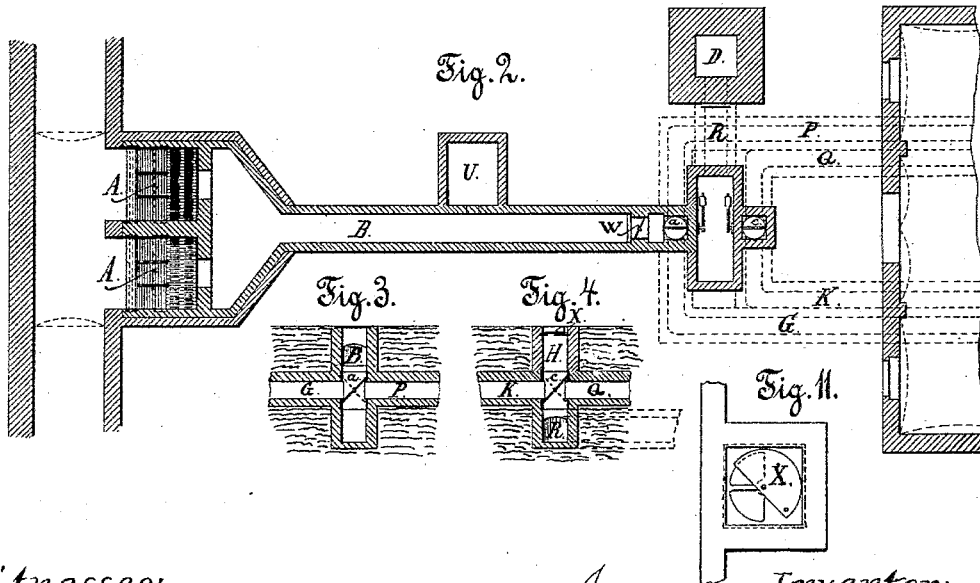

Fig. 2.

Fig. 3.

Fig. 4.

Fig. 11.

Witnesses:
John C. Fairbridge.
T. B. Kosher

Inventor:
Johann Baldermann
by his attorney
W. Briesen

J. BALDERMANN.
Lime and Other Kilns.

No. 210,834.

Patented Dec. 17, 1878.

Fig. 6.

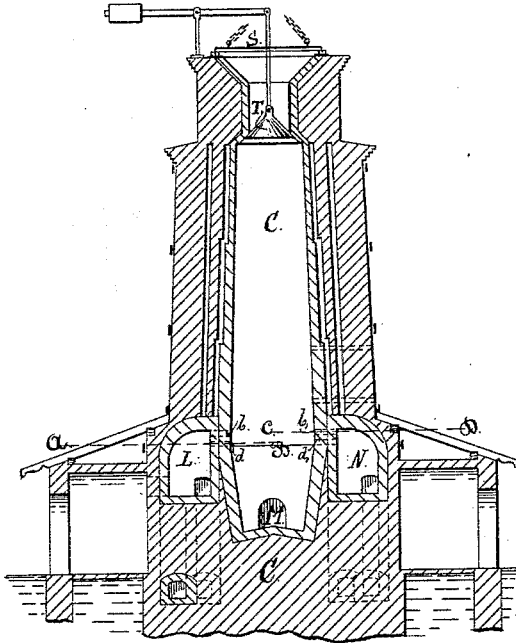

Fig. 8.

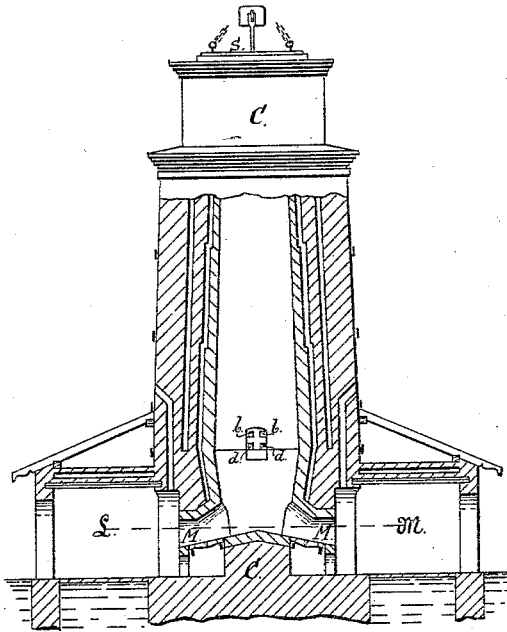

Fig. 7.

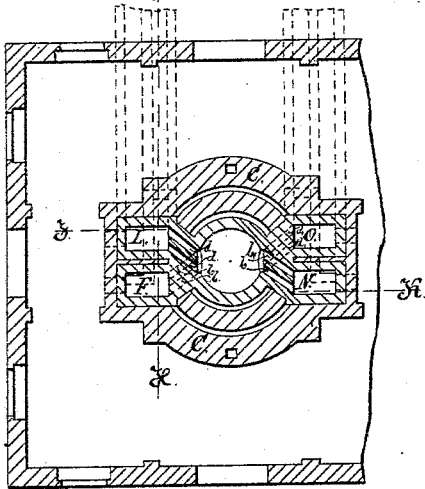

Fig. 9.

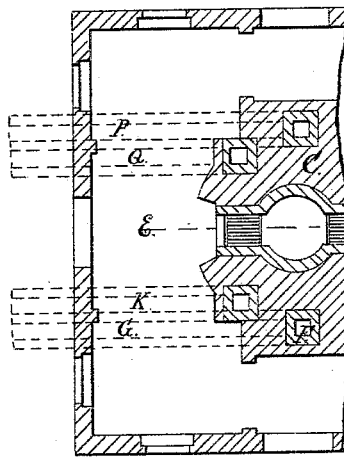
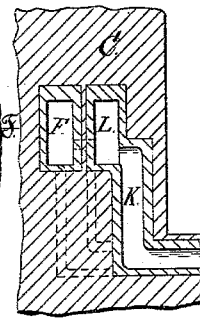

Fig. 10.



Witnesses:

John C. Tunbridge.
T. B. Mosher

Inventor:

Johann Baldermann
by his attorney
A. J. Driesen

UNITED STATES PATENT OFFICE.

JOHANN BALDERMANN, OF FINKENHEERD, ASSIGNOR TO HIMSELF AND
PAUL BERNDT, OF FUERSTENBERG, PRUSSIA.

IMPROVEMENT IN LIME AND OTHER KILNS.

Specification forming part of Letters Patent No. **210,834**, dated December 17, 1878; application filed
October 16, 1878.

To all whom it may concern:

Be it known that I, JOHANN BALDERMANN, of Finkenheerd, in the Kingdom of Prussia and German Empire, have invented Improvements in Lime and other Kilns, of which the following, with reference to the accompanying drawings, is a full and clear specification, enabling those skilled in the art to use and work the same.

Figure 1 is a vertical longitudinal section of the flues and the furnace. Fig. 2 is a horizontal section of the same; Figs. 3 and 4, vertical sections of the reversing-valves; Fig. 5, a plan of the furnace-room; Fig. 6, a vertical section of the kiln in the line I K; Fig. 7, a horizontal section on the lines A B and C D, Fig. 6; Fig. 8, a vertical section in the line E F, Fig. 7; Fig. 9, a horizontal section in the line L M, Fig. 8; Fig. 10, a partial vertical section on the line G H, Fig. 7; Fig. 11, detail view of the air regulator or register.

Similar letters of reference indicate corresponding parts in all the figures.

The invention relates to kilns for lime, plaster-of-paris, bricks, glass, and other substances; and the object is to run them continuously, not to bring the fuel in contact with the substances to be heated, but to generate gas from the former, which, by means of peculiarly-constructed regenerators, is heated, and in this hot state mixed with air, which is heated also, to ignite this mixture, and to use the flames thus produced for heating the substances within the kiln.

The object is also to utilize the fuel to its greatest advantage, to obtain the condensable products of the distilled fuel, to burn all carboniferous parts of the lime, plaster-of-paris, &c., and to avoid the smoking of such kilns, which is annoying, and in some instances poisonous, to the neighborhood.

The invention consists in first distilling in a separate furnace the fuel itself by the heat of that part of it which is burning on a grate; also, in carrying the products of this distillation a certain distance through a condensing channel or chamber, where the tar, peat, and other condensable parts are separated from the gas; thirdly, in introducing this gas, after being heated in a very hot chamber, termed the

"regenerator," through small openings, into the burning-room of the kiln. Leaving these small openings, it is mixed with hot air issuing from the openings of a similar regenerator. In the kiln the gas burns not only the air, but all the oxygen and carbon, &c., of the lime, plaster-of-paris, &c., and heats these substances; and it consists, fourthly, in carrying the hot gaseous products of the combustion into a second set of regenerators, opposite to the above-mentioned, to which they give a very high temperature, and from whence they pass through the chimney into the open air without generating any smoke.

Each set of regenerators consists in one regenerator for the gas and in one for the air, and gas and air meet only in leaving the apertures of the openings that lead to the hearth of the kiln. By this arrangement a premature ignition inside of the regenerators is avoided. The burnt substances are continuously, or at least in very short intervals, drawn from the bottom of the kiln, while fresh material is supplied at the top, which is provided with an air-lock, to prevent the gases of combustion from leaving the kiln on top, instead of passing to the second set of regenerators and the chimney. After having run the kiln about half an hour in this way the course of the gases and the air is reversed by turning a reversing-valve on the end of the condenser, and also one below the air-register, so that the gases first enter the second set of regenerators, pass on across to the first set of regenerators, and to the chimney. Half an hour afterward the gases are caused to take their first course, and so on. The regenerators are by this means alternately heated, and raise in their turn alternately the temperature of the gas and the air before the same can enter the burning-room of the kiln.

In the drawing is represented a limekiln constructed according to these principles and dispositions; but it must be remarked that the details or the arrangement of the parts in themselves or to each other may be altered as circumstances may require, and that the invention is equally applicable to the treatment of plaster-of-paris, bricks, or other substances.

A is the furnace, in which the fuel is, through

two funnels, supplied to two step-grates, in such quantity that the fuel burning upon them heats the remainder of the fuel, and distills it without forming flames. The products of the distillation enter the condensing-chamber B, which is fitted with safety plates or valves Y Y, to allow, in case of explosion, an escape of gas.

The bottom of the chamber B slopes to the center, so that the tar, peat, &c., may be collected at this point in a separate chamber, U. After having passed the damper W, arranged to regulate the quantity of the passing gas, the gas is directed by the reversing-valve *a* to the flue G, into the regenerator F, Fig. 7, and from there through the openings *b b* into the hearth of the kiln C. At the same time atmospheric air enters, through the register X, the canal H, and passes, directed by the reversing-valve *c*, to the flue *k*, and goes into the regenerator L, Fig. 7, and from there, through the openings *d d*, also into hearth of the kiln C. As the walls of the regenerators have a very high temperature, both gas and air are also heated, and unite readily to flames the moment they leave the apertures *b b* and *d d*, which cross each other, for the purpose of better mixing gas and air.

The contents of the kiln (the limestones) are thus heated to the desired degree, and the lime, properly calcined, is drawn off through the working-holes M M.

In the meantime the limestones in the upper part of the kiln gradually sink as the lime is drawn, and are heated and then calcined, and thus the drawn-off lime is replaced at the top by cold stones. At the top of the kiln is a cover, S, made air-tight by means of sand or water, and a little lower in the gorge of the kiln is a counterbalanced cone, T, both together forming an air-lock to admit a new charge without leaving the kiln open for a moment.

As the exit of the products of combustion is shut off at the top, they have to take their way into the chimney D and the open air, by means of openings *b b* and *d d*, through the regenerators N and O, and flues P, Q, and R.

The regenerators N and O, constructed exactly like F and L, are heated by the escaping flames, and the regenerators F and L cooled down by the proportionally cold coal-gases and the atmospheric air.

The reversing-valves *a* and *c* are reversed,

after a half-hour's work, to the position shown by dotted lines in Figs. 3 and 4, so that the gas and air enter first the regenerators N and O, and the hot products of combustion take their exit through the regenerators F and L, which are now reheated to a high temperature. After half an hour the valves *a* and *c* are turned into their first position, reversing the draft again, and so on.

I know that kilns have heretofore been operated by gas. I do not claim the use of a regenerator or heating-chamber for the gas in general; but

What I do claim is—

1. The arrangement herein described of double sets of regenerators F L and N O, that connect with the same kiln, C, for the purpose of permitting the current of gas and air and of the products of combustion to be reversed from time to time, substantially as specified.

2. In a lime and other kiln operated by gas, two or more sets of regenerators, which are worked alternately, substantially as described, and for the purpose set forth.

3. The reversing-valves *a* and *c*, in combination with two or more regenerators on gas-kilns for lime, plaster-of-paris, and other substances, substantially as shown.

4. A gas-kiln for lime, plaster-of-paris, bricks, and other substances, closed on top, substantially as shown, in combination with a chimney, a gas-generator, two or more alternately-working sets of regenerators, and the necessary flues, with reversing-valves, substantially as shown and described, and for the purpose set forth.

5. The arrangement and disposition of a limekiln, C, with alternately-working regenerators F L and N O, in combination with gas-generator A, condenser B, reversing-valves *a* and *c*, damper W, register X, air-lock S and T, and chimney D, as shown and described, and for the purpose set forth.

6. In combination with a kiln constructed and operated substantially as specified, the damper W and register X, arranged substantially as set forth.

This specification signed by me this 18th day of July, 1878.

JOHANN BALDERMANN.

Witnesses:

CARL T. BURRHARDT,
PAUL BERNDT.