

E. FERRET.  
Seal-Lock.

No. 210,844.

Patented Dec. 17, 1878.

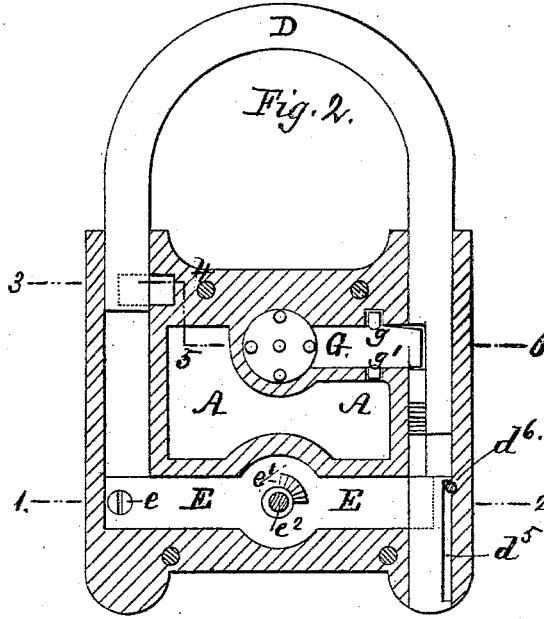
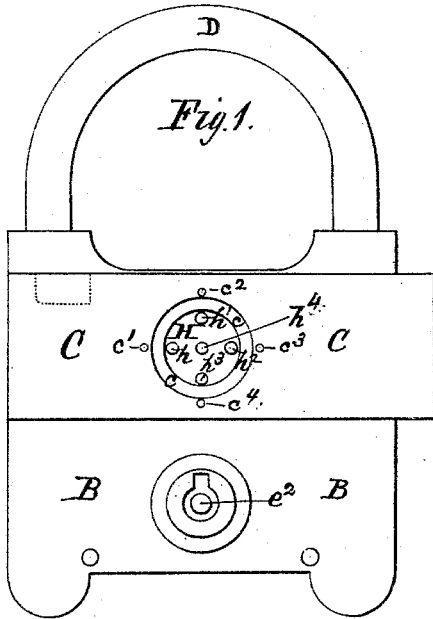

Fig. 5.

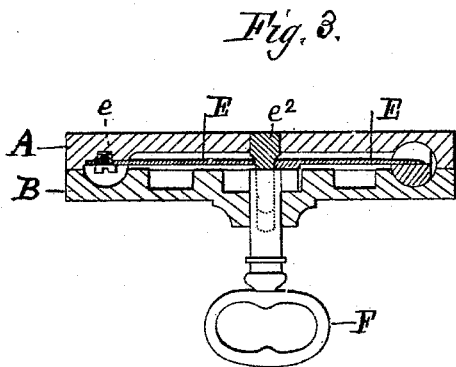

Fig. 3.

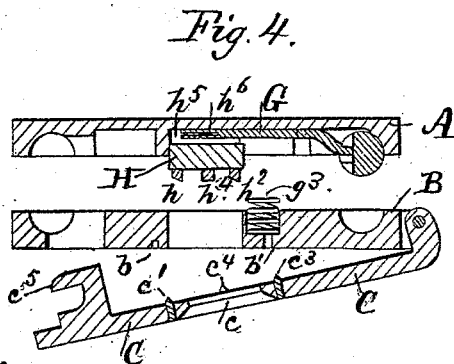

Fig. 4.

Fig. 6.

Fig. 8.

Witnesses

*Emile Barault*  
*Aug. Vireck*

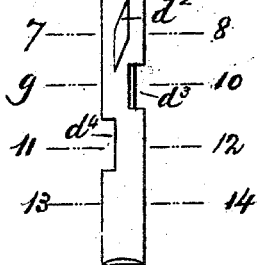

Fig. 7.

Fig. 9.

Inventor:  
*E. Ferret*

# UNITED STATES PATENT OFFICE.

EUGENE FERRET, OF PARIS, FRANCE.

## IMPROVEMENT IN SEAL-LOCKS.

Specification forming part of Letters Patent No. 210,844, dated December 17, 1878; application filed October 28, 1878.

*To all whom it may concern:*

Be it known that I, EUGENE FERRET, of Paris, in the Republic of France, have invented certain new and useful Improvements in Padlocks, of which improvements the following is a full, clear, and exact description.

The safety-padlock, subject-matter of this patent, is composed of two recessed plates, which are firmly riveted together to inclose certain movable organs and a curved rod of circular section having two branches of uneven length. A hinged perforated plate is designed to keep in place a piece of paper, which may, if desired, bear a signature or any particular or conventional sign or mark. This paper is designed to be forcibly punctured or destroyed in such a way as to be visible at the first glance of the padlock if it should have been opened.

It is hardly necessary to state that my invention consists in this particular means of control. The padlock itself may be constructed in any other convenient or suitable manner, with or without combinations or other safety appliances to prevent the picking of the lock.

In order that my invention may be fully understood, I have shown the same in detail in the annexed drawing, in which—

Figure 1 is a general elevation of the padlock; Fig. 2, a section of the same, showing the bottom or rear plate, together with the pieces of the movement, the padlock being locked. Figs. 3 and 4 are sections on lines 1 2, 3 4, 5 6 in Fig. 2, the two plates of the padlock being in juxtaposition in the former figure and slightly separated in the other figure. Fig. 5 is a side view of the curved rod; and Figs. 6, 7, 8, and 9 are cross-sections on lines 7 8, 9 10, 11 12, and 13 14.

In all these figures the same letters of reference are used to indicate the same parts.

In these figures, A is the rear plate, in the recesses of which are located the parts of the movement, as well as half of the curved rod before referred to. B is the top plate, which is riveted to the rear plate, A, and is provided with corresponding recesses to those in plate A, in which recesses is located the other half of the curved rod. C is a movable plate, being hinged to one side of plate B. It is provided with a circular orifice, *c*, on the interior

of which four small points, *c*<sup>1</sup>, *c*<sup>2</sup>, *c*<sup>3</sup>, and *c*<sup>4</sup>, are designed to traverse the marked paper and to maintain it in place behind the opening *c*. Four small holes corresponding to these points are for this purpose provided in the plate B, as shown at *b b'*.

Upon the interior face of the hinged plate C, and upon the side opposite to the hinge, is a hook, *c*<sup>5</sup>, which is designed to lock in with the shorter arm or branch of the curved rod. D is this curved rod, whose shorter arm is notched, as shown at *d*, while the longer arm is notched at different heights, as indicated in the sectional Figs. 6, 7, 8, and 9 at *d*<sup>1</sup> (having a projection, *d*<sup>2</sup>, on the face of the notch) and at *d*<sup>3</sup>, *d*<sup>4</sup>, and *d*<sup>5</sup>, the latter limiting the up-and-down play of the rod by means of a traverse-pin, *d*<sup>6</sup>.

E is a steel spring, held at one of its extremities by means of a screw, *e*, and having toward the center a segmental inclined plane, *e*<sup>1</sup>. The other extremity of this spring rests in the notch *d*<sup>4</sup> of the curved rod. This spring is furthermore traversed by a spindle, *e*<sup>2</sup>, with which the barrel of the key F engages, and upon which it revolves.

G is a transmission-lever, having two pivots, *g g'*, lodged in suitable bearings on the bottom plate, A. One of the extremities of this lever is actuated in either the one or the other direction by means of the lozenge-shaped projection *d*<sup>2</sup> when the rod D rises or falls. A helical spring, *g*<sup>2</sup>, placed in a circular opening in the plate B, keeps this lever in the bottom of a recess for it provided in the rear plate, A.

H is a cylinder, carrying at its front end five bevel-edged pins, *h h*<sup>1</sup> *h*<sup>2</sup> *h*<sup>3</sup> *h*<sup>4</sup>, and is provided at its rear end with projections *h*<sup>5</sup>, between which is placed a small pin, *h*<sup>6</sup>, which unites said cylinder with the split extremity of the transmission-lever G.

These are the different parts of mechanism of which my padlock is composed, and now it will be easy to understand its operation.

Suppose the padlock be closed, and consequently that all the pieces are in the position shown in Fig. 2. Suppose, further, that a piece of paper marked in a particular manner is held between the movable plate, C, and the top plate, B, opposite to the circular opening *c*. When the key F is introduced in the lock and turned

to the position shown in Fig. 3, then the inclined plane, against which the ward of the key presses in rotating or in turning, forces the spring E into its recess and out of the recess or notch  $d^4$  in the long arm of the rod D, thus releasing and enabling it to rise, during which movement the lozenge-shaped projection  $d^2$ , pressing against the extremity of transmission-lever G, will cause the bevel-pointed pins of the cylinder A to pierce the paper in five different places, which will be perfectly visible on inspection of the lock. After the passage of the lozenge-shaped projection the transmission-lever G, actuated by the helical spring  $g^3$ , will resume its position. It follows, therefore, that if the padlock had been opened the pierced paper would tell the tale, and it could not be replaced without detection, owing to the particular sign or mark the paper is intended to bear.

Having thus described my said invention, what I claim, and desire to secure by Letters Patent, is—

1. The combination, in a padlock, with a

mechanism for piercing paper which is held exposed to view on the face of the lock, of a curved rod or hasp, the longer arm of which is capable of sliding and rotating in its bearing, said arm being notched, as described, to actuate said mechanism, substantially as herein shown and set forth.

2. A padlock composed of two recessed plates and a hinged movable plate, in combination with a curved rod provided with recesses and projections, and also with spring-plate and a transmission-lever, as hereinbefore described, the latter actuating, when the padlock is opened, a cylinder provided with piercing-points, all substantially as herein shown and set forth.

In testimony whereof I have signed my name to this specification before two subscribing witnesses.

EUG. FERRET.

Witnesses:

EMILE BARRAULT,  
AUG. VINCK.