

A. S. HALLIDIE.
Clip for Rope Tramways.

No. 210,851.

Patented Dec. 17, 1878.

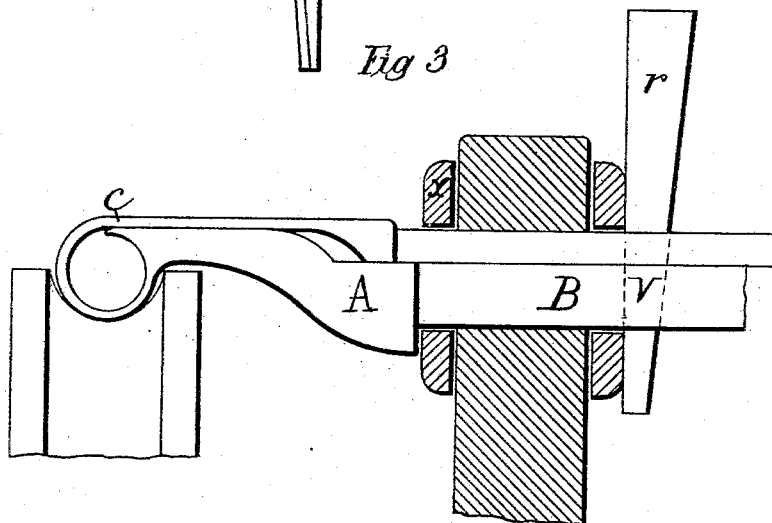
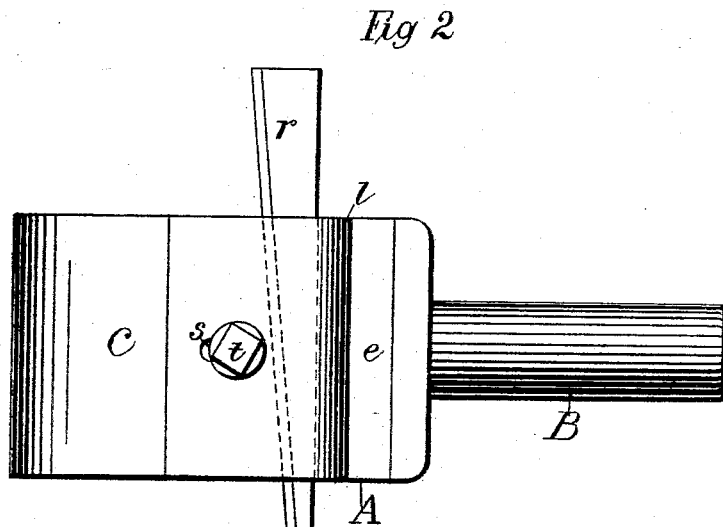
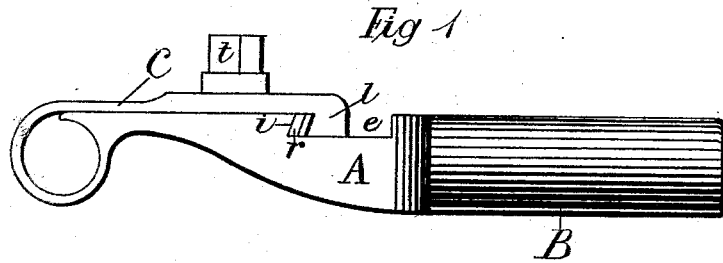

Witnesses
D. B. Lawler
W. P. Clark

Inventor
Andrew S. Hallidie
per J. L. Boone
Attorney

UNITED STATES PATENT OFFICE

ANDREW S. HALLIDIE, OF SAN FRANCISCO, CALIFORNIA.

IMPROVEMENT IN CLIPS FOR ROPE TRAMWAYS.

Specification forming part of Letters Patent No. 210,851, dated December 17, 1878; application filed September 11, 1878.

To all whom it may concern:

Be it known that I, ANDREW S. HALLIDIE, of the city and county of San Francisco, State of California, have invented an Improved Clip for Rope Tramways; and I do hereby declare that the following is a full, clear, and exact description thereof, reference being had to the accompanying drawings.

My invention has reference to an improved arrangement for tightening clips on wire ropes, and it applies more especially to such clips as are used on endless ropeways for sustaining and carrying the bucket or other load which is to be transported by the rope.

My invention is an improvement upon the device for which Letters Patent No. 110,971, dated January 17, A. D. 1871, and No. 115,310, dated May 30, A. D. 1871, were granted to me.

Referring to the accompanying drawings, Figure 1 is a side view. Fig. 2 is a plan view. Fig. 3 is a side view of variation of Figs. 1 and 2.

A represents the body of the clip, and B the shaft, from which the bucket or other body is suspended by means of a hanger. C is the thin metallic leaf, which forms a part of the body A, and is bent around so as to encircle the rope and lap back over the body of the clip, as shown.

The body A, I make considerably thicker toward the outer end, from which the shaft B projects; and at a short distance from the base of the shaft I make a wide transverse groove, *e*, entirely across it. This groove is wider at one end than the other, so that its inner edge or shoulder *i* is slightly diagonal; and this inner edge or shoulder is inclined inward, so as to form an acute angle.

The portion of the leaf C which encircles the rope, and also for a short distance along the lap is made thin, so as to be flexible, while the remaining portion is made thicker, so as to be comparatively inflexible. The extremity of this leaf is bent downward into the transverse groove *e*, so as to form a lug, *l*, the inner edge of which is inclined or beveled in the same direction that the edge *i* is inclined. I then insert a wedge-shaped key, *r*, into the space between the shoulders *i* and lug *l*. The opposite edges of this wedge are inclined, to correspond with the inclines of the edges *i* *l*,

so that it has a tendency to draw the two parts together. Now, by driving this wedge farther in, the lap is drawn forward and the coiled portion is tightened upon the rope.

To prevent the lapped portion C from being displaced by the strain, I make a slotted hole, *s*, in the re-enforced or thickened part, and insert a screw or bolt, *t*, through the slot, and secure it in the body-piece A. The head of the bolt or screw prevents the leaf from lifting, while the slot allows it to move end-wise as far as the wedge will draw it, thus tightening it up.

Fig. 3 is a similar device for obtaining the same result, on which I intend to make application for Letters Patent. The thin metallic leaf C is continued and forms a part of the shaft B, which is divided into two parts parallel with its axis, the lower portion being a part of the body A, and the upper portion a part of the leaf C, both together forming the shaft B. A slotted keyway, V, is cut in each part of the shaft B, so that a wedge-shaped key, *r*, inserted therein will draw the upper part of the shaft over the lower part, so as to tighten the band or leaf C over the rope. A collar, *x*, is fitted on the shaft B, so as to form a shoulder for the hanger of the bucket, and in order to keep the two parts of the shaft B together. The wedge-shaped key *r* has an intervening washer, which acts as a shoulder on the outer portion or end of the shaft B, and prevents the hanger of the bucket slipping off.

This arrangement provides a simple, cheaply made, and effective tightening device for clips for wire-rope ways, and which can be tightened by the simple stroke of a hammer.

Having thus described my invention, what I claim, and desire to secure by Letters Patent, is—

1. A clip for wire ropes, having the transverse groove *e*, and the extremity of the lapped portion C bent downward into the groove, so as to form a lug, *l*, in combination with the wedge or key *r*, substantially as and for the purpose described.

2. The body A of a rope-clip, made gradually thicker toward its outer end, and provided with a transverse groove, *e*, the inner edge or shoulder of which is made inclined and diagonal, as described, and having the

extremity of the overlapped leaf C provided with a lug, *l*, the inner edge of which is inclined in the same direction, in combination with the wedge-shaped key *r*, with its correspondingly-inclined edges, substantially as and for the purpose described.

3. The overlapping leaf C of a rope-clip, provided with the slotted hole *s*, and having the screw or bolt *t*, passing through the slotted hole, and secured in the body-piece A, in combination with a wedge-shaped tightening device, substantially as and for the purpose described.

4. The wedge-shaped key *r*, as described, for acting upon and varying the binding or griping strain of the leaf C upon the wire-rope, substantially as and for the purpose described.

In witness whereof I have hereunto set my hand and seal this 10th day of August, A. D. 1878.

ANDREW S. HALLIDIE. [L. S.]

Witnesses:

WILLIAM HARNEY,
H. R. COUSINS.