

W. A. KNOWLTON & A. RUTLEDGE.
Cultivator.

No. 210,861.

Patented Dec. 17, 1878.

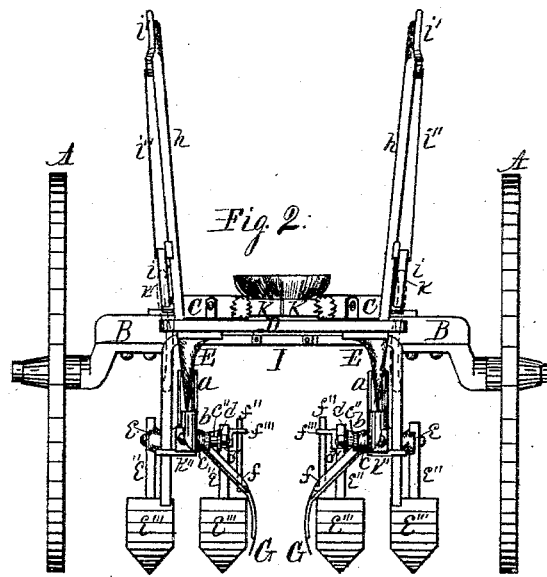
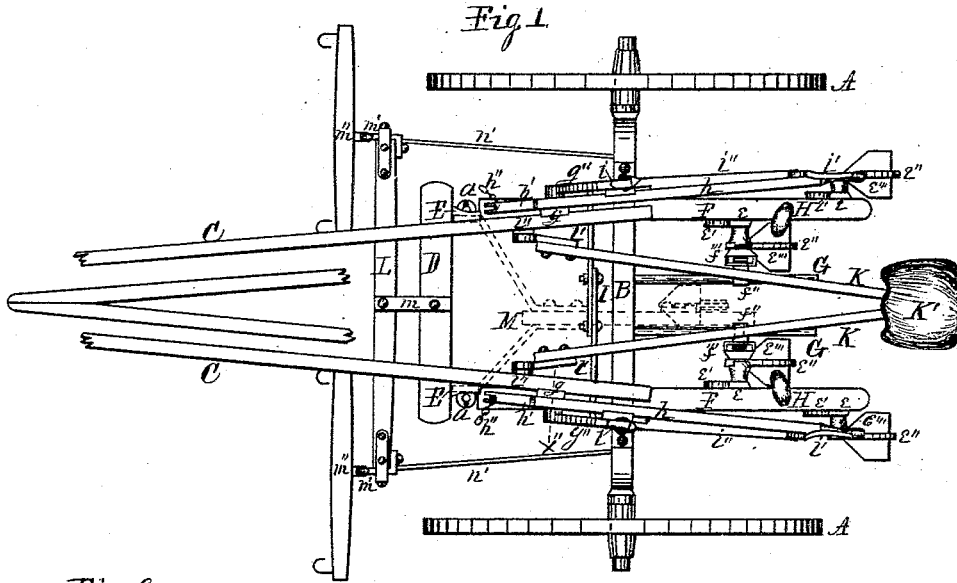

Witnesses.
A. O. Behl
Sovereign

Inventor.
William A. Knowlton.
Andrew Rutledge.
Per. Jacob Behl
Atty.

W. A. KNOWLTON & A. RUTLEDGE.
Cultivator.

No. 210,861.

Patented Dec. 17, 1878.

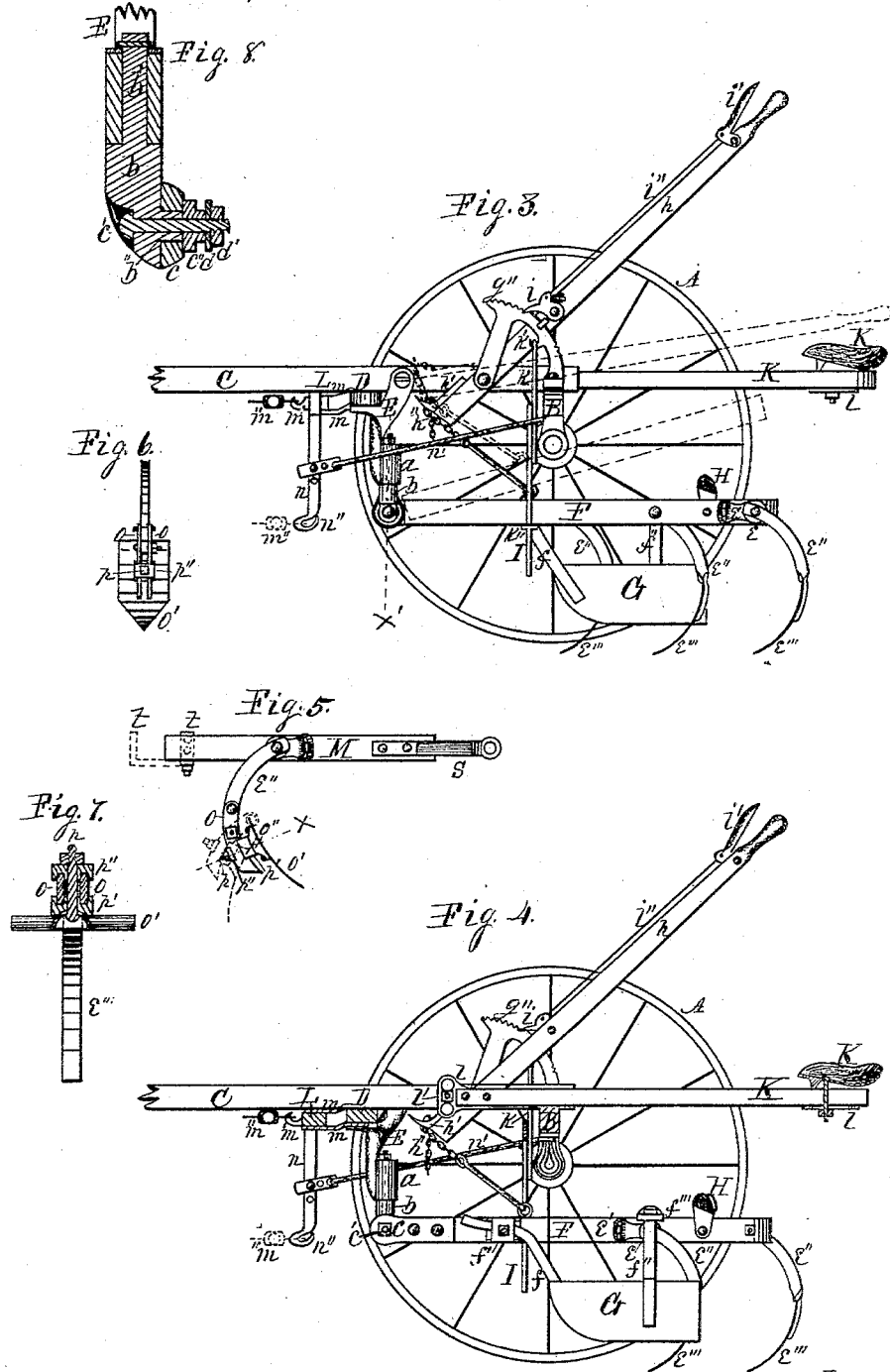

Witnesses.
J. O. Behl
Edouard

Inventor.
William A. Knowlton,
Andrew Rutledge,
Per. Jacob Behl,
Atty.

UNITED STATES PATENT OFFICE.

WILLIAM A. KNOWLTON AND ANDREW RUTLEDGE, OF ROCKFORD, ILLINOIS.

IMPROVEMENT IN CULTIVATORS.

Specification forming part of Letters Patent No. 210,861, dated December 17, 1878; application filed April 30, 1878.

To all whom it may concern:

Be it known that we, WILLIAM A. KNOWLTON and ANDREW RUTLEDGE, of the city of Rockford, in the county of Winnebago and State of Illinois, have invented a new and useful Improvement in Cultivators, of which the following is a specification:

This invention relates to that class known as "straddle-row sulky-cultivators," designed for use on the farm mainly in the cultivation of such crops as are usually grown in hills, check-rows, or in drills.

The object of our improvement is to produce at a reduced cost a more efficient machine, and one that is capable of all the uses to which this class of machines is applicable. To this end we have designed and constructed the machine represented in the accompanying drawings, in which—

Figure 1 is a plan view of the machine embodying our invention, of which Fig. 2 is a front elevation; Fig. 3, a side elevation, in which the rear carrying-wheel is omitted, and Fig. 4 is a lengthwise vertical central section. Fig. 5 is a side elevation of the center or fifth shovel and shovel-beam. Fig. 6 is a rear view of the shovel-standard with the shovel thereto attached. Fig. 7 is a transverse section of the parts on dotted line *x*, Fig. 5. Fig. 8 is a transverse vertical section of the front joint on dotted line *x'*, Fig. 3. Fig. 9 is a transverse vertical section on dotted line *x''*, Fig. 1.

In the figures, A are carrying-wheels fitted to revolve on axle-arms, secured to the under side and ends of the axle-tree B. The tongue is composed of two beams, C, having their rear ends secured to the upper side of the axle-tree toward its outer ends. These beams converge as they extend forward and meet at their forward ends, where they are fixed to each other and fitted to receive the neck-yoke. These beams are connected by a transverse bar, D, bolted to their under sides about on line with the forward portion of the carrying-wheels, and its ends extend beyond the outside of the tongue-beams. These parts constitute the main carrying-frame, and are substantially the same as in some other machines now in common use.

E are pendants fitted with a shoulder-plate adapted to receive the under side of the outer

ends of the transverse bar connecting the tongue-beams, and are firmly bolted thereto. These pendants are provided with a bracing-arm extending rearward and upward to meet the outer face of the tongue-beams rearward of the transverse beam, and are firmly bolted thereto. The lower ends of these pendants are fitted with a vertical socket, *a*, to receive the journal-arm of the central portion of the joint, which connects the drag-bar to the pendant.

b is the center portion of the joint connecting the forward end of the drag-bar with the pendant. Its upper portion, *b'*, is of journal form, fitted to oscillate freely in the socket *a* in the pendant. The lower end of this center portion of the hinge is of disk form, provided with a stud, *b''*, which projects from the center of its face side at right angles thereto. The center of this stud is bored to receive a bolt.

c represents a joint-plate fitted to receive the forward end of the drag-bar, to which it is firmly bolted. Its forward end extends beyond the forward end of the drag-bar, and is of disk form, centrally bored to receive the stud *b''* of the center portion *b*.

e' is a screw-bolt, which is passed through the center of the stud. *e''* is a tubular washer having a disk-like base, and is placed on the screw-bolt against the end of the stud *b''*. *d* is an ordinary washer of large size, placed on the screw-bolt against the end of the tubular washer. The screw-nut *d'* is then turned up against the washers, which force them against the stud *b''*, and holds the parts in position in such a manner as to permit of a free up-and-down movement of the rear end of the drag-bar, and at the same time prevent any axial or rolling motion thereof, and the oscillation of the journal-arm *b'* in the socket *a* in the pendant will permit of the required lateral movement of the rear ends of the drag-bars.

F are the drag-bars, to which the joint-plates are secured that connect them by hinge-joint to the pendants. *e* are shovel-standard brackets, consisting of a stud slotted on its outer end to receive the upper end of the standards, to which the shovels are attached, which, with the stud, is bored to receive a screw-bolt, to pass through the drag-bar, stud, and shovel-

standards to fix them in place thereon. The inner ends of these studs are provided with a plate-like arm, e' , which extends lengthwise of the drag-bars. Their forward ends are slotted radially, and their outer faces are serrated to receive serrated washers.

Suitable screw-bolts are passed through the drag-bars, the slotted ends of the arms, and through the serrated washers, and receive screw-nuts, by which the parts are held in position on the drag-bars, to hold the shovels attached to the standards in working position.

By means of the radially-slotted arms and the clamping screw-bolts, the working-angle of the shovels may be changed by raising or lowering the slotted end of the arm. These standard-brackets, with standards having shovels thereto attached, are fixed to the rear portion of the drag-bars on their opposite sides, and at proper intervals, to insure the complete working of the shovels.

e'' represents the shovel-standards, which are made from rectangular bars, curved as represented, having the shovels e''' , of the usual form, attached to their lower ends. G are shields, made from plate material, and of the form represented, provided at their forward ends with an upward-rising arm, f , of such form as to meet the inner face of the drag-bar in advance of the shield-plate, at which point it is received on a pivot-bolt in a lengthwise X-formed slot in the plate-bracket f' , which is secured in place on the drag-bar by the pivot screw-bolt passed through the drag-bar, the bracket f' , and the shield-arm f . The edges of the X-formed slot furnish inclined shoulders to limit the downward movement of the shields. These shield-plates are provided toward their rear ends with an upward-rising guide-arm, f'' , the upper end of which is received in a lengthwise slot in the inward-projecting arm of the bracket f''' , secured to the shovel-standard bracket by the same bolt that secures the bracket and shovel-standard to the beam. This arm and its connection with the slotted bracket gives lateral support to the shields, and permits of their free vertical movement to override obstructions.

H are foot-rests secured to the drag-bars, and are designed to receive the feet of the operator when mounted in the seat, and furnish the means by which to impart the lateral movements to the drag-bars, to cause the shovels to conform to the sinuosities of the rows of plants. g are flanged plates fitted to embrace the tongue-beams, and are provided with a center tubular stud, g' , adapted to serve as a fulcrum, on which the raising and lowering levers h are pivoted. g'' are segment-ratchets provided with a foot-plate to rest on the upper face of the axle-tree, to which they are firmly bolted. The forward upper portions of these ratchets are provided with a radius-bar, having their lower ends fitted to receive the end of the tubular studs g' , and a sufficient screw-bolt is passed outward through the tongue-beams, tubular studs, and the lower

end of the radius-bar, provided with a screw-nut, by means of which the parts are firmly clamped to each other and held in place.

The segment-ratchets g'' are of that class known as the "saw-toothed ratchet," and are provided near their base with a few such teeth, and at their upper forward ends with a series of similar teeth, leaving a blank between the toothed portions.

The forward ends of the levers h , pivoted on the tubular studs g' , are provided with slotted hook-plates h' , fitted to engage the links of the suspension-chain h'' , the rear ends of which are connected to the drag-bars, rearward of their connections with the forward ends of the levers, and in connection with the levers are employed to raise and lower the drag-bars and the shovels thereto attached. The levers h are fitted with a spring-pawl, i , fitted to engage the teeth of the ratchet, and are operated by a thumb-lever, i' , pivoted to the handle end of the levers, and connected with the spring-pawl by a linked rod, i'' . These parts are of such construction that in depressing the hand end of the lever the pawl will override the ratchet-teeth, but will engage them to prevent the lever rising, and when disengaged from the teeth, near the base of the segments, will freely slide upward over the blank portion of the segment until it comes in contact with the teeth on the upper forward portion of the ratchet.

From the foregoing it will be seen that by means of the slotted hook h' and the links of the chain h'' , the parts may be adjusted to cause the plows to run at a proper working depth when the pawl engages the first rearward tooth on the upper portion of the segment, which will furnish a ready method of adjusting the plows to a proper working depth; but this depth may be increased by changing the pawl to any of the teeth higher on the segment, or its working depth may be lessened by hooking the chain higher in the slotted hooking-plate on the lever. By depressing the lever until the spring-pawl engages the ratchet-teeth at the base of the segments, the drag-bars and their attachments will be held in an elevated position, for the purpose of transportation, or for any other purpose requiring their elevation.

In this construction of our improved cultivator, the points on which the drag-bars are supported as the pivotal points of their lateral swinging movements are so nearly in the same vertical line that the lateral swinging movements of the shovels in the cultivation of crops will be practically in the same horizontal plane. I is a sway-bar composed of two like halves made from bar material bent edgewise, each half forming two sides of a rectangle, and placed in such a manner that one leg of each half shall overlap each other in such a manner that the bent bars shall form three sides of a rectangle, and the overlapping portions forming the crowning portion of the sway-bar are provided with a series of holes in corresponding pairs to receive

screw-bolts to hold them firmly connected, and by means of which, in connection with the corresponding pairs of holes, are made adjustable to increase or lessen the distance between their depending legs. The sway-bar I, as described, is suspended in front of the axle-tree to swing parallel thereto on radius-links *k*, pivoted to its depending legs and supported on hooks *k'*, which project from the lower side of the segment-ratchets outside of the lifting-levers to swing freely without interfering with the levers. The depending legs of this sway-bar pass through guide-loops *k''*, secured to the drag-bars, which permit of an independent vertical movement of the drag-bars, but control their lateral movements to cause them to move in unison, and, by means of the screw-bolts and the corresponding pairs of holes in the overlapping parts of the crowning portion of the sway-bar, the rear ends of the drag-bars may be adjusted toward or from each other to plow closer to or farther from the plants. The seat-frame is composed of beams *K*, bolted to each other at their rear ends, and diverge as they extend forward over the axle-tree to meet the inner faces of the tongue-beams forward thereof, and are provided with a lengthwise-slotted plate, *l*, to receive the screw-bolt, which secures the seat *K'* to the seat-frame, and is made lengthwise adjustable thereon by means of the lengthwise-slotted plate to balance the machine and accommodate different operations. The forward ends of these diverging beams *K* are provided with metallic plates *U*, the outer faces of which are parallel lengthwise, and adapted to meet the inner faces of the angle-blocks *U''*, secured to the inner faces of the tongue-beams. The forward ends of the plates *U* are provided with a series of holes in a vertical line to receive the bolts which are passed through the tongue-beams and through blocks *U'*, and furnish the means for the vertical adjustment of the seat, and hold the seat-frame pivoted on the axle-tree, and the parallel faces of the plates on the forward ends of the seat-frame permit it to be turned forward on the tongue-frame, when the machine is used as a walking-cultivator, or for any other purpose, without strain on the bolts which connect it with the frame of the machine.

L represents an evener, which is centrally pivoted to draft-bars *m*, connected to transverse bar *D*. The outer ends of the evener are provided with hooks *m'* to receive the whiffletrees *m''*. These parts constitute the evener as commonly employed; but to adapt it for use on the machine when employed as a walking-cultivator or as a stalk-cutter, I have provided the vertical eveners *n*, pivoted at their upper ends to the outer ends of the horizontal evener, and centrally to the axle-trees by draft-rods *n'*. The lower ends of these vertical eveners are provided with a hook, *n''*, to receive the whiffletree *m''*, and when so employed in use will relieve the downward draft of the tongue on the necks of the team. These

vertical eveners and their connections with the horizontal evener and axle-tree are of such construction as to admit of their removal and application as circumstances may require, and in each instance in use, either single or compound, to be a complete operating evener.

M represents the beam of the center or fifth shovel frame, with a three-part shovel-standard thereto attached, in which *o* are curved plates, of any suitable material, fitted one to each side of the main standard *e''*. These plates are provided with holes near the center of their length that correspond with the hole in the lower end of the standard, and receive a screw-bolt or rivet, which fixes them in position on the standard in such a manner as to permit them to turn as on a pivot. The upper ends of these plates are provided with a hole, which meets a corresponding hole in the standard, and are provided with a frangible pin sufficient to bear the resistance of ordinary cultivation.

o' is the shovel, fitted with a hollow shovel-back, *o''*, having convex outer surface slotted transversely to permit the shovel to be turned to the right or left on a bolt, *p*, passed from its inner side outward. A block, *p'*, having its outer face concave to receive the convex outer surface of the shovel-back, is grooved vertically on its opposite side to receive the forward edges of the plates *o*, and a block, *p''*, is grooved vertically on its forward side to receive the rear edges of the plates *o*. These blocks *p'* and *p''* are provided centrally with holes to receive the screw-bolt *p* from the shovel-back, which passes through them and between the plates *o*, and is provided with a screw-nut on its outer end, by means of which the parts are clamped together to hold the shovel in position on the standard. By means of this device the shovel may be turned to the right or left, to throw the earth to or from the plants. It may be adjusted up or down on the standard to regulate its relative working depth, and the frangible pin in its upper end will be broken under severe strain, and permit the shovel to turn back to pass rigid obstructions, and prevent breaking the shovels. To the forward end of the drag-bar *M* are secured bracing-like arms *s*, the forward ends of which are bored to receive the necking of the tubular washer *e''* on the center screw-bolt *e'*, and inside of the common washer *d*. The rear end of the drag-bar *M* is fitted with the right-angled arm *t*, bolted to its under side. Its upward-projecting arm is provided with holes to receive the inner end of the bolt that connects the forward shovel-standard to the drag-bar, which serves to give steadiness to the center shovel, and puts it under the control of the movements of the drag-bar, to which it is connected. This center or fifth shovel is represented in position in dotted lines in the plan view at Fig. 4, and is designed for use in the preparation of the soil, preparatory to planting, seeding in, and other purposes for which a cultivator is applicable on a farm.

We claim as our invention—

1. A pendant provided with bracing-arms adapted to be secured to the side of the tongue-beam and to the under side of the cross-bar connecting the tongue-beams, the lower end of said pendant provided with a socket, in combination with a joint-bar having a journal, *b'*, which turns within the socket on the pendant, the lower end of the joint-bar provided with a stud, *b''*, and the plate of the drag-bar journaled on said stud and secured by a bolt, substantially as set forth.

2. The evener having end hooks rigidly secured thereto for the attachment of the whiffletrees, in combination with removable vertical eveners pivoted to the straps of the end hooks, the lower ends of said vertical eveners provided with hooks to receive the whiffletrees, and draft-links secured at their rear ends to the axle-tree, while their forward ends are attached to the vertical eveners, substantially as set forth.

3. The combination, with the herein-described three-part shovel-standard, of grooved blocks adapted to receive the forward and rear

edges of the side plates of the standard, and adapted to receive a shovel on the front side of the forward block, held in place thereon and made vertically adjustable on the standard by a screw bolt or bolts passed from the front through the parts between the side plates of the standard.

4. The combination, with the three-part shovel-standard herein described, of grooved blocks adapted to receive the forward and rear edges of the side plates of the standard, the front face of the forward block adapted to receive the convex surface of the shovel-block secured to the shovel, and held in place and made adjustable on the standard by means of the screw-bolt in the slot of the shovel-back passing through the grooved blocks and between the side plates of the shovel-standard, substantially as and for the purpose hereinbefore set forth.

WILLIAM A. KNOWLTON.
ANDREW RUTLEDGE.

Witnesses:

A. R. ALBERTSON,
A. O. BEHEL.