

V. & F. BECKER Baling-Press.

No. 210,901.

Patented Dec. 17, 1878.

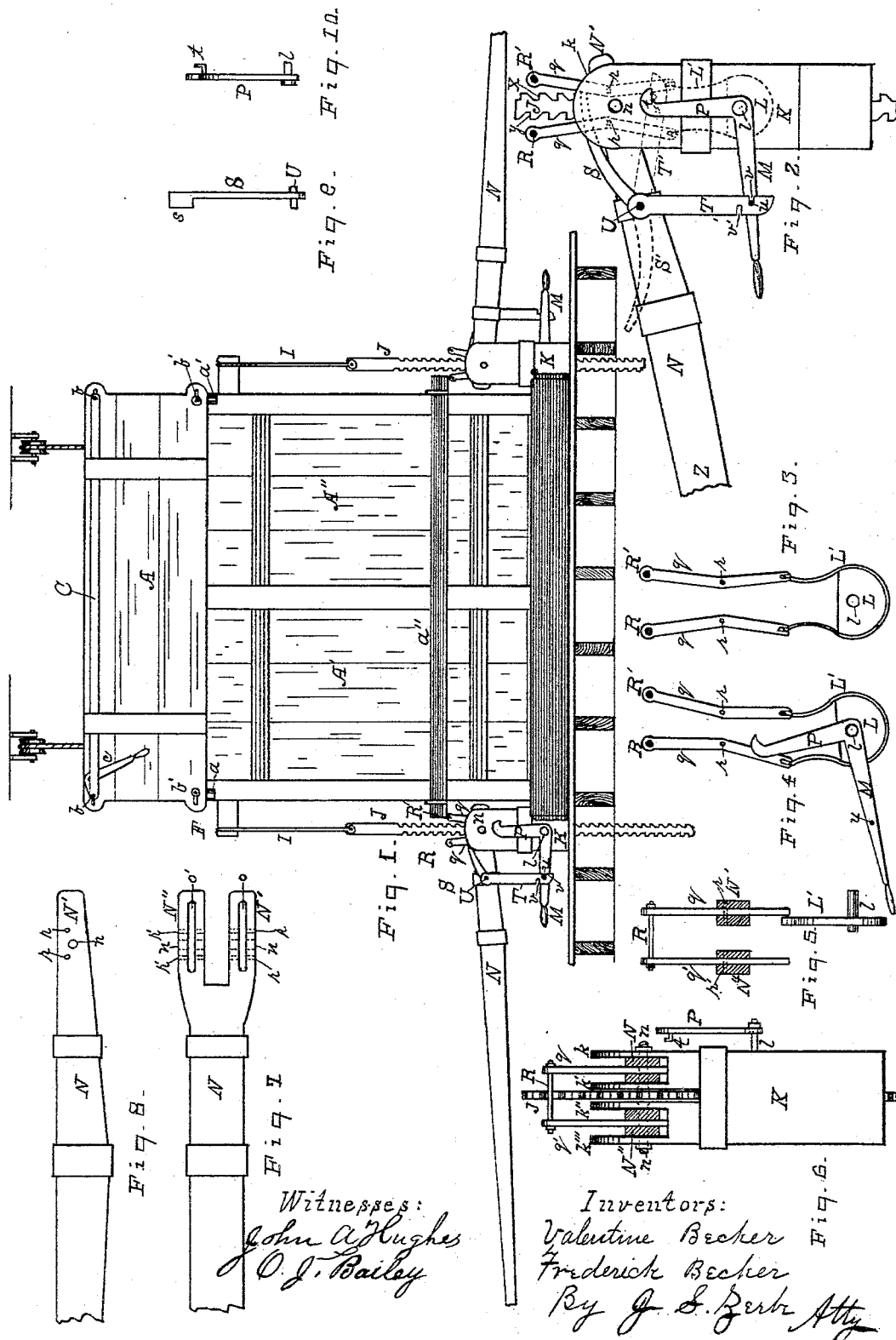

Witnesses:
John A. Hughes
O. J. Bailey

Inventors:
Valentine Becker
Frederick Becker
By J. S. Berke Atty

V. & F. BECKER
Baling-Press.

No. 210,901.

Patented Dec. 17, 1878.

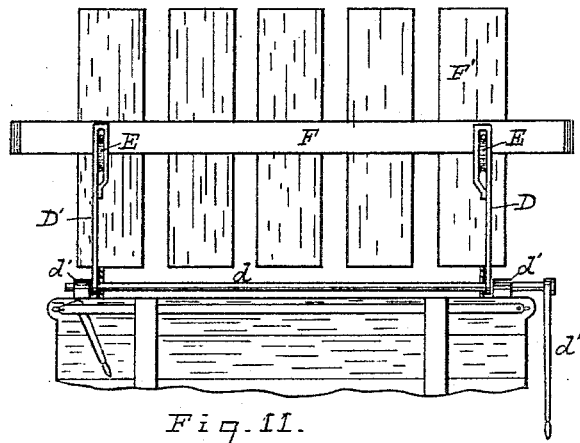

Fig. 11.

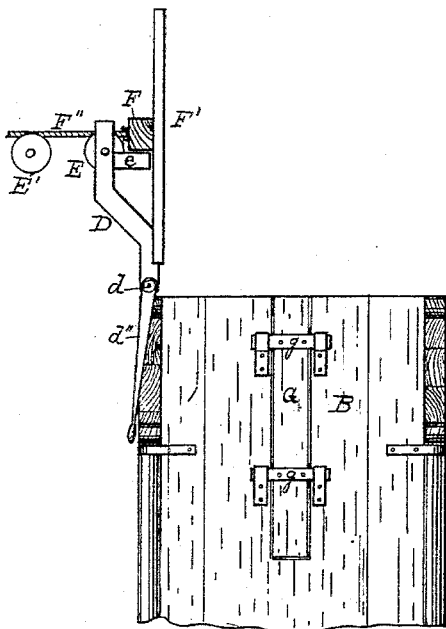

Fig. 12.

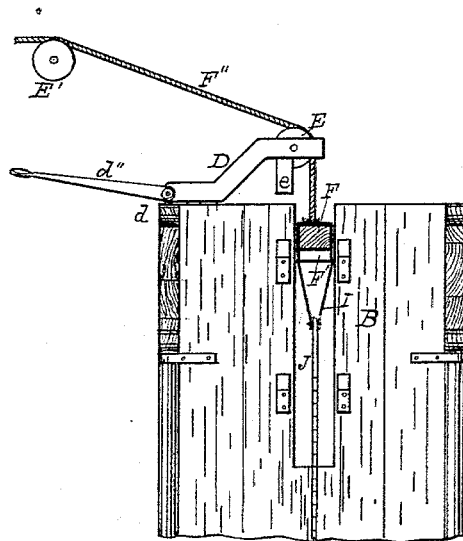

Fig. 13.

Witnesses:
John A. Hughes
O. J. Bailey

Inventors:
Valentine Becker
Frederick Becker
By J. S. Perbe
Atty

UNITED STATES PATENT OFFICE.

VALENTINE BECKER AND FREDERICK BECKER, OF CINCINNATI, OHIO.

IMPROVEMENT IN BALING-PRESSES.

Specification forming part of Letters Patent No. 210,901, dated December 17, 1878; application filed May 6, 1878.

To all whom it may concern:

Be it known that we, VALENTINE BECKER and FREDERICK BECKER, of Cincinnati, in the county of Hamilton and State of Ohio, have invented a new and useful Improvement in Rag Lever-Presses, which improvement is fully set forth in the following specification and accompanying drawing, in which—

Figure 1 represents a side view of our rag-press, with lever and ratchet attachment; Fig. 2, enlarged side view of ratchet and lever; Figs. 3, 4, and 5, detail views of same; Fig. 6, end view of ratchet mechanism; Fig. 7, top view of operating-lever; Fig. 8, side view of same; Figs. 9 and 10, detail drawings of sub-levers for operating ratchets; Fig. 11, side view of upper portion of the press-box, showing elevation of the follow-board; Fig. 12, end view of press-box, with follow-board drawn from the press-box; and Fig. 13, end view of the press-box, showing follow-board adjusted and ready for baling.

This invention relates to that class of presses used for baling purposes, and the object of our invention is to provide a press which shall be so constructed as to easily admit material to be baled, and is also so arranged that the bale can be readily drawn from the press. In addition thereto we have constructed an improved ratchet mechanism, by means of which, in connection with levers operating double ratchet-bars, a powerful pressure can be produced, and also by which pressure is exerted by the upward as well as the downward motion of the power-lever. The ratchet mechanism also provides for automatically retaining the ratchet in any position, and is so constructed that the follow-board can be released from pressure to any degree desired, as will hereinafter be more fully described and set forth.

In the drawing, Fig. 1, A represents the box of our press, having at its side two doors, A' A'', hinged at a a', and held in position by cross-bar a''. The upper side parts, A, of the press are fastened to the end B, Fig. 12, by means of the bolts b b'; but these bolts are loose enough to allow the ends of the press to be thrown out or compressed. C represents a bar or rod connecting the two end pieces, B, of the box; and pivoted at one end thereto is an

elbow-lever, c, for compressing or releasing the said ends.

D D' represent standards attached to rod d, said rod being pivoted at d', and provided with a lever, d'', at one end. The standards D D', have at their upper ends an extension or rest, e, and pulley E. Attached to the ceiling is another pulley, E', arranged in line with pulley E, as shown.

F represents the cross-beam of the follow-board F'. The follow-board when drawn from the press is put in a vertical position, as shown in Fig. 12, the beam F resting on e, the rope F'', for raising the follow-board, being attached to the cross-beam F and passed over pulleys E E'. G represents an end piece for closing the box preparatory to filling, and is held in position by means of cross-pieces g g. I is a loop, which is placed on the ends of the cross-beam F, to which is attached a bar, J, having ratchets on both edges. This bar passes through case K, containing levers and pawls for operating the same. The case K is provided at its upper end with four ears, k k' k'' k'''. Within the lower part of the case, and at one side of the ratchet-bar J, a semicircular block, L, is fixed on a shaft, l, one end of which shaft or journal extends through one side of the case K, and to which is rigidly attached lever M. Around the semicircular block L a spring, L', is bent and firmly attached thereto, the free ends of the spring extending above the block a sufficient distance to give them flexibility. These ends are also slightly bent apart from each other.

The power-lever N is constructed with two ears, N' N'', said ears being provided with longitudinal slots o o'. The lever N is placed in the case, as shown in Figs. 2 and 6, and pivoted by bolt n. We then provide four levers, slightly bent, and pass them through the longitudinal slots in the following manner: Levers q q being placed one on each side of the bolt n, through the aperture or slot o, and lever q' q' in like manner through the slot o', in both instances the convexity of the levers being toward each other, the upper ends of the levers q and q' are now connected by means of bolts R R', which are used as pawls for operating ratchet-bar J. The levers q q' are pivoted to the ears N' N'', as shown at r r', and

the lower ends of q are slotted, and connected by studs or otherwise with the upper end of the spring L' , heretofore described.

The lever M has a right-angled upward extension, P , beyond the fulcrum l . Near the upper end of the extension P , on its reverse side, is a hooked stud or pin, t . At a like distance from the fulcrum l , and on the face side of the lever M , is a similar pin, u .

A slightly-curved arm, S , and a straight arm, T , are attached to lever N at a suitable distance from bolt n by means of bolt U . The arm S , at its free end, is somewhat flattened, terminating in an ear or side projection, s , as shown in Fig. 9. Arm T , at its free end, is provided with notches v v' .

We will now describe the operation of the press and attachments in detail. Figs. 11 and 12 represent the position of the upper part of the press preparatory to filling the box with the material to be baled. This being done, the end piece, G , is taken out. The lever d'' is then thrown upward, which lowers the pulley E , and with it the follow-board F' . The loop I on ratchet-bar J is now adjusted on the ends of beam F , and the press is ready for the operation of the levers to compress the same.

In Fig. 2 we have represented the handle of lever N as being at its lowest point. If, now, the curved arm S be thrown into the position indicated by dotted lines S' , the withdrawal of ear s from between the levers q q will allow the pawls R R' to act against the bar J , the spring L below causing the pawls R R' to near each other. We will therefore suppose that the pawl R' engages the tooth in bar J . (Indicated by X .) At the same time it will be observed that the stud u in lever M has engaged in notch v of arm T . The handle of the lever (indicated by Z) is now raised, which causes the pawl R' to descend, bringing the bar J with it, and also correspondingly raising pawl R . It will also be seen that the upward movement of lever N correspondingly raises lever M , and, since spring L' is rigidly connected with lever M , the movement throws the upper ends of the springs to the right and the upper ends of the levers q to the left, thus preventing the pawl R' from becoming disengaged. When the handle at Z is lowered, the lever M , spring L' , and levers q act in the opposite direction, and the pawl R engages tooth y . It will thus be seen that a downward pressure is exerted on bar J whether the lever N be raised or lowered.

When the material in the press is sufficiently compressed, the bar a'' is removed and the doors A' A'' are opened, and the bale tied. It is now desired to release the pressure from the bale. To accomplish this the arm T is thrown

into the position indicated by the dotted lines T' , the notch v' engaging in the hooked pin t in the upper part of lever P . The change in the position of this arm, it will be perceived, also changes the motion of the spring L' and levers q . We will now suppose that pawl R engages the tooth y , the lever N being at its lowest point. As the lever is raised the arm T , actuating lever P , throws said lever toward the left, and causing the upper ends of levers q to move toward the right, keeping pawl R from disengaging on one side, and preventing pawl R' from engaging on the other side. The upward motion allows the bar J to ascend, relaxing the pressure. As the lever N is again lowered, lever P moves toward the right and pawl R' to the left, until it engages the tooth next below, when the pawl R will become disengaged, and perform the same operation heretofore described. When the pressure on the bale is sufficiently relaxed, the arm S' is thrown into the position indicated at S , the upper part of the levers q are drawn apart, and the ear s placed between them to prevent the pawls from operating against the bar J . The teeth on the bar J are arranged thereon alternately, thereby enabling the operator to exert the same power by a shorter sweep of the lever N .

It will thus be seen that the entire operation of the levers, both in exerting the pressure on the bale and in releasing the same, is automatic.

Having thus described our invention, what we claim as new, and desire to secure by Letters Patent, is—

1. In a lever-press case, K , provided with spring L' , block L , rigidly attached to levers M and P , levers q q' , connected by bolts R R' , and arms S and T , when used in combination with lever N and alternate ratchet-bar J , substantially as herein described.

2. In a lever-press, the combination of lever N , having arms S and T , with ratchet-bar J , case K , provided with levers M P q q' , and spring L' , or its equivalent, substantially as herein described.

3. In a lever-press, the combination of rod d , standards D D' , hinged thereto, beam F , ratchet-bar J , case K , and operating mechanism connected therewith, and lever N , substantially as described and herein set forth.

In testimony that we claim the foregoing we have hereunto set our hands this 27th day of April, 1878, in the presence of witnesses.

VALENTINE BECKER.
FREDERICK BECKER.

Witnesses:

O. J. BAILEY,
F. E. ZERBE.