

T. E. MARTIN.
Wind-Mill.

No. 210,950.

Patented Dec. 17, 1878.

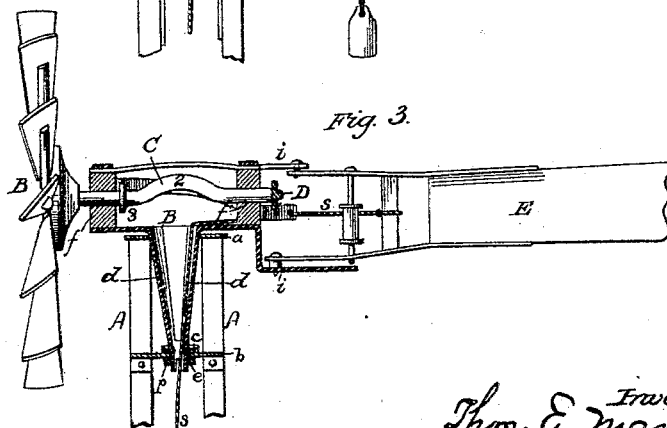
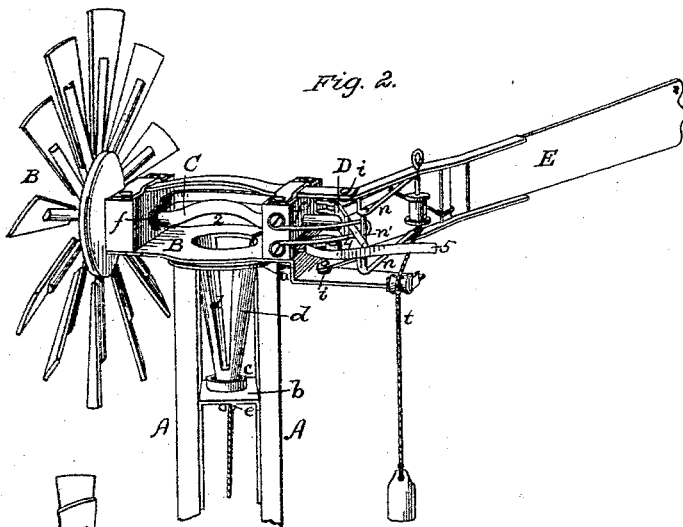
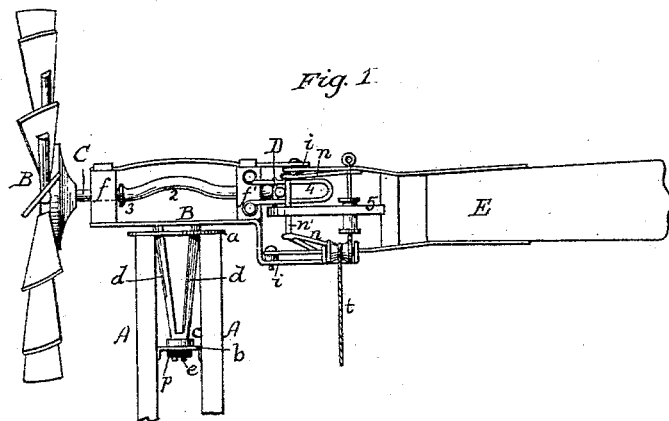

Witnesses:
Clarence Poole
R. K. Evans

Inventor:
Thos. E. Martin
by A. S. Conno, Secy
Atty

UNITED STATES PATENT OFFICE.

THOMAS E. MARTIN, OF SAN JOSÉ, CALIFORNIA.

IMPROVEMENT IN WINDMILLS.

Specification forming part of Letters Patent No. 210,950, dated December 17, 1878; application filed October 29, 1878.

To all whom it may concern:

Be it known that I, THOS. E. MARTIN, of San José and State of California, have invented certain Improvements in Windmills; and I hereby declare the following to be a full, clear, and exact description thereof, reference being had to the accompanying drawings, making part of this specification, in which—

Figure 1 is a side elevation of my windmill with the wheel in the wind. Fig. 2 is a perspective view of my mill with the wheel thrown out of the wind. Fig. 3 is vertical section through the turn-table.

The object of my invention is to provide a wind-wheel which will be automatically adjustable as the force of the wind varies; and it consists in a wheel mounted on a shaft which has lateral play in the turn-table, and abuts against a movable latch, through which means a thrust is made against the vane in such a manner as to change its position and throw the wheel out of the wind as its force increases.

My invention further consists in a spring-adjuster fastened to the turn-table and bearing against the vane, so that it increases in power as it is forced back by the wheel coming into the wind, and the mill is thereby steadied, and in violent storms the wheel will not go entirely off the wind, but will throw off just enough to slow down the speed.

My invention further consists in the details of mounting the turn-table.

In order that those skilled in the art may make and use my invention, I will proceed to describe the manner in which I have carried it out.

In the said drawings, A A are posts supporting the wheel turn-table. On the tops of the posts A A is fastened a metal collar, *a*, and a short distance below it a plate, *b*, provided with a central socket, *c*. The turn-table plate B has an opening corresponding to collar *a*, and from it depends two supports, *d d*, passing through collar *a*, and terminating in a spindle, *e*, which rests in central socket *c*. The turn-table is supported by *d d*, and turns on them, they acting as a spindle. The wind-wheel B is mounted on the end of shaft C, which is journaled at *f f'*, and is provided

with a crank, 2. Between the bearings, and between the crank 2 and wheel B, the shaft C has a fixed collar, 3. This construction gives the shaft a longitudinal play from collar 3 to the wheel. The rear end of shaft C bears against a movable latch, D, which is hinged to journal-block *f'*, for a purpose hereinafter described.

The vane E is hinged to the turn-table on projections *i i*, and has on its side a projecting frame, *n n n'*, one side of said frame being diagonal to the vane, and the side next the turn-table is at right angles to the vane. The vertical bar *n'*, at the angle of said frame when the wheel is directly in the wind, bears against the end of the movable latch D, and keeps it close to the journal-block *f'*. The movement of the end of the latch D is limited by means of a looped stop, in which it moves, the said stop 4 being fastened to the end of journal-block *f'*.

To the rear side of block *f'* is fastened a spring, 5, which curves outward and rearward and bears against bar *n'*, so that as the vane comes up into the wind there is a steady and constantly-increasing pressure kept upon it.

The shut-off rope *s* and the weight-rope *t* are applied in the usual manner.

A nut, *p*, on the end of the supporting-spindle, prevents any tendency the turn-table may have to lift when the wheel is doing heavy work.

Having thus described my invention, what I claim as new, and desire to secure by Letters Patent, is—

1. A windmill provided with a longitudinally-moving shaft, C, in combination with the mechanism shown, for moving the same by means of a thrust from the shaft, substantially as described.

2. The movable shaft C, hinged latch D, and stop 4, in combination with the vane E and frame *n n n'*, as set forth.

3. The curved spring 5, in combination with the vane E and frame *n n n'*, constructed and arranged substantially as described.

THOMAS E. MARTIN.

Witnesses:

H. W. PLATT,
S. W. PLATT.