

W. G. RHOADS.
Siphons.

No. 210,965.

Patented Dec. 17, 1878.

Fig. 1.

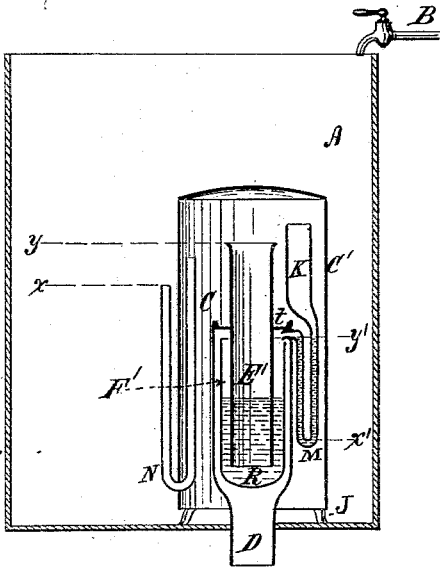

Fig. 2.

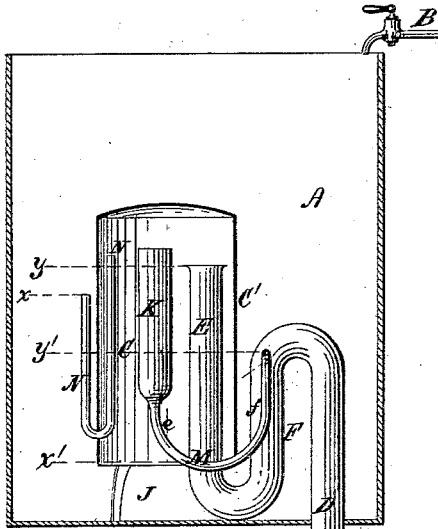

Fig. 3.

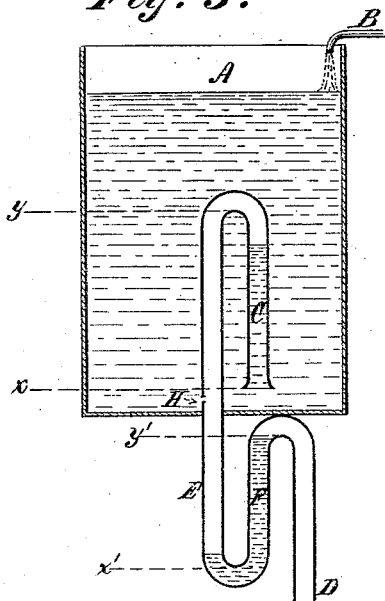
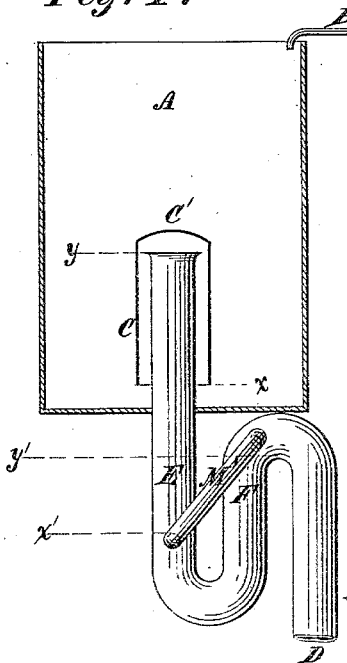

Fig. 4.



Witnesses:

Geo. W. Mott
S. A. Banks

Inventor:

Wm. S. Rhoads
By David A. Burr
att.

W. G. RHOADS.
Siphons.

No. 210,965

Patented Dec. 17, 1878.

Fig. 5.

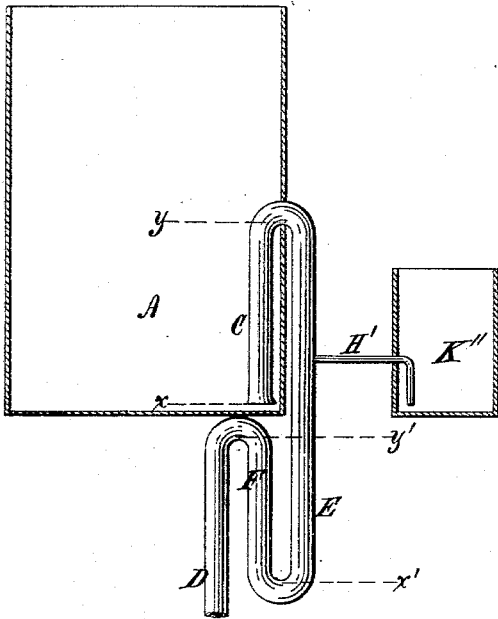

Fig. 6.

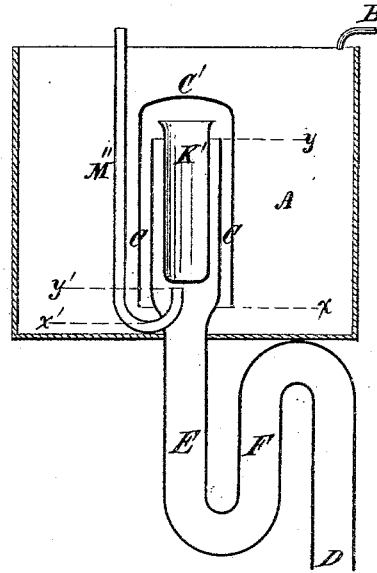

Fig. 7.

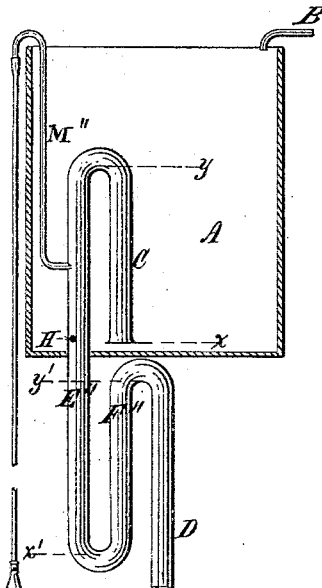
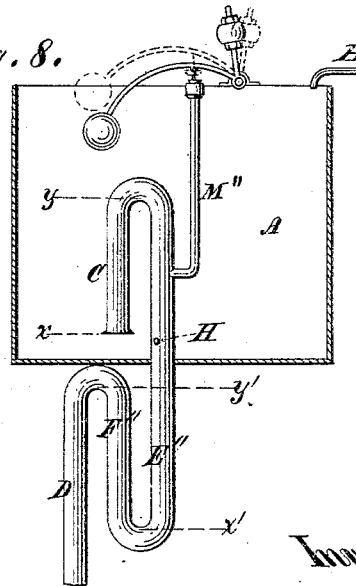

Fig. 8.



Witnesses:

Geo. H. Smith
J. H. Banks

Inventor:

Wm. G. Rhoads.
 By David A. Burr
 atty.

UNITED STATES PATENT OFFICE.

WILLIAM G. RHOADS, OF PHILADELPHIA, PENNSYLVANIA.

IMPROVEMENT IN SIPHONS.

Specification forming part of Letters Patent No. 210,965, dated December 17, 1878; application filed October 12, 1878.

To all whom it may concern:

Be it known that I, WILLIAM G. RHOADS, of the city and county of Philadelphia, and State of Pennsylvania, have invented a new and useful Improvement in Siphons, of which the following is a specification:

My invention relates to that class of siphons which are designed more especially for use in flushing and cleansing drain-pipes, water-closets, sewers, &c., and for similar purposes; and its object is to produce an action of the siphon more simply and effectively than has hitherto been done.

It consists in connecting a trapped siphon of novel construction with a tank or reservoir to be discharged by its action, in such manner as that a column of air shall be automatically confined and compressed within the siphon by the rise of water in the tank as it is filled, so as to produce a difference of the fluid-level within and without its intaking-leg when the tank is full; and in the subsequent release of this confined air to permit a rise of the depressed level, and thereby charge the siphon and bring it into action.

It consists, moreover, in the combination, with the trapped siphon, of devices for automatically maintaining the seal in its trap by refilling the same when it is exhausted by the discharge of the siphon, and also of devices for accomplishing and facilitating the release of the air at the proper moment, as desired.

In the accompanying drawings, Figures 1 and 2 illustrate my invention in its most complete automatic form. Figs. 3 and 4 illustrate the same in simplest form. Fig. 5 illustrates the combination of an external charging-tank with the siphon; Fig. 6, a modification in the combination of vent-tube and charging-cup with the automatic siphon; and Figs. 7 and 8, modifications of the invention, whereby the siphon is brought into action at will by hand, instead of automatically.

My improved siphon, as illustrated in Fig. 2 of the drawings, is constructed of a pipe, D, bent into the form of a trap, E F D, having its upper end inclosed and covered by a cap, C'. A cup, K, is properly supported near to the upper open end of the trapped pipe E D, so as to project slightly above it. A small vent-tube, M, is connected to the bottom of

said cup K, trapped by means of a suitable bend therein, and carried and connected to the upper outer bend of the main trap E F, at a point above its overflow-level, in such manner as that it may discharge into its uptake-arm F.

The dotted lines $x' y'$ indicate, respectively, the sealing and overflow levels of the trap $e f$ in the tube M, which must in all cases be so constructed as to have a less depth of seal than the main trap E F.

The charging-cup K is made of a capacity exceeding that of the traps in the main and vent tubes, so that its contents shall suffice to fill them both.

The covering-cap C', which constitutes, in fact, the shorter intake-leg of the siphon, may be supported by lugs J, serving as feet, to rest upon the bottom of the tank, or be otherwise secured to the siphon; and it is made to inclose the cup K, as well as the end of pipe E, sufficient space being left above each to permit a free flow therinto.

A small tube, N, is inserted with a tight joint through the side of the cap C', near its lower edge, and its two ends are bent upward within and without the cap C', that end which is left lowermost serving to determine the sealing-level x of the siphon or level at which an escape of air from its intake-leg C at ordinary pressure is cut off by an access of water thereto. This sealing-level x must be so adjusted with reference to the capacity of the intake-leg C of the siphon and of the intake side e of the trap $e f$ in tube M as that the capacity of the intake C of the siphon between its said sealing-level x and its overflow-level y shall fully exceed the capacity of the intake side of the said trap between its sealing-level x' and the customary upper level of its sealing-charge, which I denominate its "charge-level," and which ordinarily, although not necessarily, will coincide with its overflow-level y' .

The trapped siphon C D, formed by the bent pipe E F D and concentric cap or cover C', is secured in place within a tank or reservoir, A, by carrying the lower end, D, of the discharge-pipe through the bottom of the tank with a water-tight joint, care being taken that the distance between the top of the siphon and the uppermost fluid-level of the reservoir shall be

greater than the depth $x' y'$ of the trap in the vent-tube M.

The successful operation of the apparatus is promoted in proportion as the discharge-pipe D is lengthened and extended downward.

The reservoir is fed by a supply-pipe, B, the supply being regulated at pleasure by means of a cock in said pipe.

The capacity of the siphon C D is, preferably, made to exceed that of the supply-pipe B, so as to carry off the water and prevent an overflow of the tank when full, even should there be a full flow from said pipe.

In starting this apparatus for the first time the siphon must be flushed so as to overflow, or the traps at F and in M be otherwise filled. When these traps are duly sealed the siphon is ready for action. If water be now allowed to flow into the reservoir A, it will rise on the same level inside and outside the receiving-leg C of the siphon until it begins to run into the stop-tube N at x , and thus prevents any further escape of air from the siphon. The water will then cease rising inside the cover, except slowly as the water-level in the intake of the traps E, F, and M becomes depressed because of increasing pressure thereon, until the water outside the cover C' is high enough above the water inside to force the water out of the vent-tube M, which, because of the small diameter of said tube, will be effectually and instantly accomplished so soon as the column of air forced thereinto from the siphon reaches its lower bend. When this takes place the release of the air in the siphon through said tube M will allow the water within the cover C' to rise toward the level of that in the reservoir, and cause such an overflow of the siphon as to start it into action. The siphon, being now at work, will rapidly lower the water in the tank until the water-level, simultaneously falling in the tube N, passes below its bend, and, permitting an inflow of air, will thus quietly and suddenly stop the action of the siphon before its lower end is uncovered.

The water falling in the discharge-tube D will suck the water out of the traps at M and E F; but the charging-cup K will be left full, and its contents, flowing through the tube M, will refill both traps and leave the siphon in condition to be again brought into action by the filling of the reservoir, as before.

Although it will usually be more desirable to place the trap E F in close proximity to the top of the siphon, the apparatus will operate efficiently with a suitable trap formed at any desired point in the discharge leg or pipe of the siphon, however remote, if it be properly charged and sealed, as set forth.

In Fig. 1, I have illustrated a modification of my invention, in which a concentric trap is substituted for that formed by the bent pipe E F. (Shown in Fig. 2.) In this case the upper end of the discharge-pipe D is enlarged to receive a cup, R, which rests therein upon suitable sup-

porting-lugs, with its upper edge somewhat below the upper edge of said pipe D. The trap is completed by a short open-ended tube, E', supported centrally within the cup R, as shown in the drawing, by means of an encircling flange, t , projecting from the tube E', and screwing into the upper end of the pipe D, so as to close the same. The trapped vent-tube M passes through the side of the pipe D, near its upper end, with a tight joint, and projects over the edge of the cup R, so as to discharge thereinto.

In determining and defining the proper proportions to be observed between the capacity of the intake-leg of the siphon and that of the intake of its trap when an automatic action of the apparatus is required, any level which the water is made to assume or will naturally assume within the trap after the siphon is at rest will constitute what I herein term its "charge-level." Ordinarily the charge-level will coincide with the overflow-level of the trap; but where a charging-cup, K, is used, as shown in Figs. 1 and 2, the volume of the sealing-fluid to be left in the trap when the siphon is at rest, and consequently its charge-level, will be regulated and determined by the size of said cup K, and may be fixed at a point much below that at which the trap will overflow.

In Fig. 3, I have illustrated the simplest form of my invention when adapted for automatic operation. It consists of a plain bent siphon-tube, C D, passing, with a suitable joint, through the bottom of the tank A, and trapped by means of an upward bend, F, in its longer or discharge leg, so that a pneumatic seal will be produced and maintained in said longer leg by means of a charge of water retained in said bend. The capacity of the intaking-leg C of the siphon, between its sealing and overflow levels $x y$, must be made to exceed the capacity of the receiving or intake side E of the trap between its sealing-level x' and its charge-level, which in this case will naturally coincide with the overflow-level y' , so that when a column of air becomes confined in the siphon between the water in the trap and the water rising in the intake-leg of the siphon the volume of air in its intake-leg C below its overflow-point y shall be enough greater than the volume of water then in the receiving side E of the trap above its sealing-point x' as to insure a complete displacement of this water by the air before the water rising in the siphon has reached the overflow-point. (See, for illustration, dotted lines within the siphon and trap in Fig. 3.)

In this, as in all proper forms of my apparatus, the hydrostatic pressure of the column of water in the uptake or discharge side F of the trap or traps of the siphon will operate, through the intervening column of air, to prevent the water entering the siphon from attaining the level of the water outside of it, and this difference of level, maintained so long as

the column of air is confined in the siphon, will, when destroyed by a release of the air, operate to flush and start the siphon.

In view of the fact that the trap E F must be sealed before the siphon begins to fill, in order to insure the confinement of a suitable column of air therein, a very small aperture, H, may be pierced in the siphon above the trap, to communicate either directly with the reservoir A, below the sealing-level x of the siphon, as shown in Fig. 3, or otherwise, by means of a connecting-tube, H', with a separate independent reservoir, K'', as shown in Fig. 5, so that a charge of water sufficient to seal the trap may invariably flow therein before it becomes essential that an escape of air from the siphon shall cease. The use of a charging-cup, K, placed within the siphon above the trap, as shown in Figs. 1 and 2, is preferable where it is found desirable to avoid the slight waste of water which will result from a constant discharge from the tank A through an aperture, H, as in Fig. 3.

In the automatic operation of a trapped siphon constructed in simplest form, without auxiliary air-vent, as shown in Figs. 3 and 5, so soon as the trap E F is supplied with sufficient water to seal it, and the water slowly flowing into the reservoir A from its supply-pipe B has risen far enough therein to cover the mouth of the siphon, the air caught between the column of water rising in the siphon and the water-level in the trap is confined and gradually compressed, and serves to transmit the weight and pressure of the rising column of water in the reservoir to the column of water in the intake side of the trap. As the water gradually rises, therefore, in the reservoir, its increasing pressure gradually forces the water out of the trap, as shown in Fig. 3, (see dotted lines,) and the displacement of the column of water in the intake side E, by depriving the column of water in the uptake or discharge side F of its counterbalancing support, operates to transmit and transfer the entire weight and pressure of this uptake column of water to the water-column in the reservoir. The level of the water in the reservoir must therefore reach a height above the level of the water entering the siphon greater than the height of the uptake column of water in the trap, so as to wholly counterbalance it, before the water in the intake side can all be forced out. So soon as this difference of level between the column in the reservoir and that in the siphon is attained, and the confined column of air in the siphon has, in its forced advance under pressure, displaced the water in the intake side of the trap, it will begin to pass into the uptake and be at once discharged. Its escape and discharge at this point, and the consequent immediate diminution of its volume and pressure within the siphon, will permit a corresponding inflow of water from the reservoir, the which, when the water-level in

the siphon is near the overflow-point, will suffice and serve to produce such an overflow as will bring the siphon into active play.

It will be observed that the functions of the small auxiliary vent-tube M, employed in connection with the siphons shown in Figs. 1 and 2, for effecting a release of the confined air to start the siphon, are performed, in the simple automatic siphon shown in Figs. 3 and 5, directly through the siphon-tube itself.

In Fig. 4 a simple form of concentric siphon properly trapped, as above described, is represented, with an auxiliary vent-tube, M', connecting a point in the intake side of the siphon-trap E F slightly above its sealing-level with the discharge-pipe at the upper bend of said trap. The vent-tube is, in this case, sealed in common with the main trap; but, having a less depth of seal, it will operate to suddenly discharge the air confined in the siphon before it has reached the sealing-level of the trap, substantially as is accomplished by means of the trapped tube M in the apparatus shown in Figs. 1 and 2.

In Fig. 6 a form of my apparatus is illustrated in which an auxiliary trapped vent-tube, M'', is carried immediately to the outer air at top of the tank, instead of mediately to the discharge-pipe, as in Fig. 2, and an independent charging-cup, K', is placed directly within the upper end of the discharge-pipe, the general operation of the device being similar to that of the forms of siphon shown in Figs. 1 and 2.

Figs. 7 and 8 illustrate siphons embodying a modification of my invention, to permit of its being operated at will by hand, instead of automatically, as also by means of a float in the reservoir. In this form of my improved apparatus the discharge-pipe of the siphon is provided with a trap, E'' F'', having an intake, whose capacity between its sealing and overflow levels x' y' exceeds that of the intake x y of the siphon, so as to prevent an automatic discharge of the air confined in the siphon; but the required difference of fluid-level within and without the siphon having been produced by the confinement of air therein through the agency of the sealed trap E'' F'' of the siphon, substantially as is hereinbefore described, the release of the air-column within the siphon required to permit a sudden rise of the water-level therein for the purpose of bringing it into action is produced either by means of an elastic bulb, S, or other equivalent air-exhausting device to be operated by hand, and which is connected with the vent-tube M'', communicating with the air-space in the siphon, as shown in Fig. 7; or else by means of a cock or a valve controlling the vent-tube M'', and which may be opened to permit an escape of the confined air either by means of a cord or other suitable device to be operated at will; or else automatically by means of a float and lever balanced by a weight, and

connected to the valve by a chain, so as to suddenly lift the valve whenever the tank becomes full, as is fully illustrated in Fig. 8.

I contemplate, likewise, adapting the form of apparatus shown in Fig. 4 for operation at will, instead of automatically and intermittently, by dispensing with the vent-tube M', deepening the trap, and so arranging the cap or cover C' as that it may be lifted and dropped again at pleasure by means of any suitable mechanical device for the purpose whenever it may be desired to start the siphon after the tank is full, and a difference of level has been established within and without the intake of the siphon, as hereinbefore described.

I do not claim as new the combination, with a tank or reservoir, of a trapped siphon whose overflow-bend rises above the tank; nor yet a trapped siphon whose trap does not admit of becoming or of remaining sealed after the flow of water through the siphon has ceased.

I claim as my invention and desire to secure by Letters Patent—

1. The combination of a column of water covering the intaking-leg and bend of a siphon with a column of water in the trap of said siphon, and with an intermediate confined and

compressed column of air, to produce a difference of fluid-level within and without said intaking-leg, for the purpose of bringing the siphon into action by the release of the air, and the consequent flow of the water toward a common level, all substantially as herein set forth.

2. The combination, with a reservoir, of a trapped siphon having its top bend below the high level or top of the reservoir, and so constructed as that the capacity of its intaking-leg between its sealing and overflow levels shall exceed the capacity of the intaking side of its trap between its sealing and charge levels, substantially as and for the purpose herein set forth.

3. The combination, with a trapped siphon, of an air-releasing or vent tube, substantially as and for the purpose herein set forth.

4. The combination, with a trapped siphon, of a charging cup or reservoir, for the purpose of refilling and sealing the trap after the action of the siphon has ceased, substantially as herein set forth.

W. G. RHOADS.

Witnesses:

WILLIAM RUDOLPH,
ROBT. G. LOUGHERY.