

J. GERARD.
Fastener for Meeting Rails of Sashes.

No. 211,005.

Patented Dec. 17, 1878.

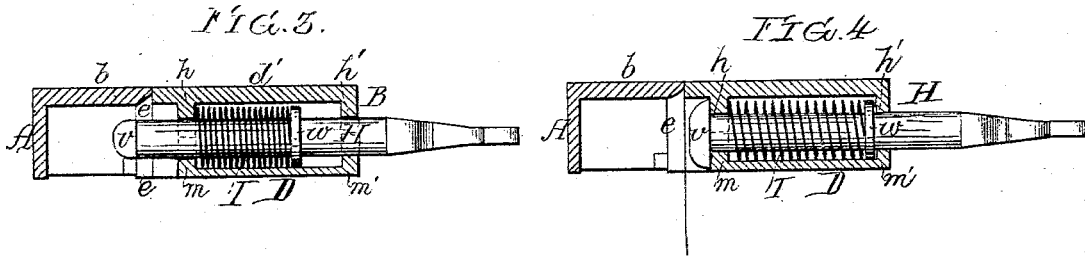
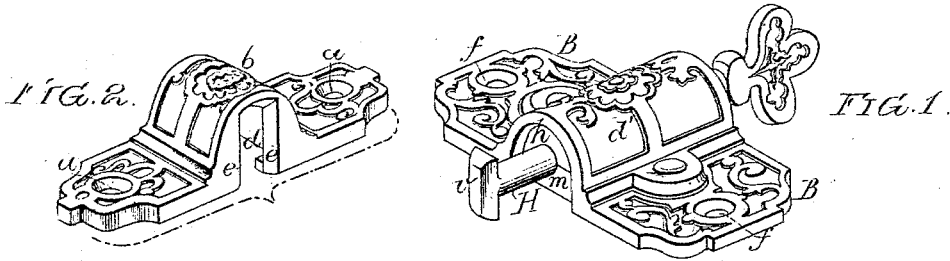

FIG. 5.

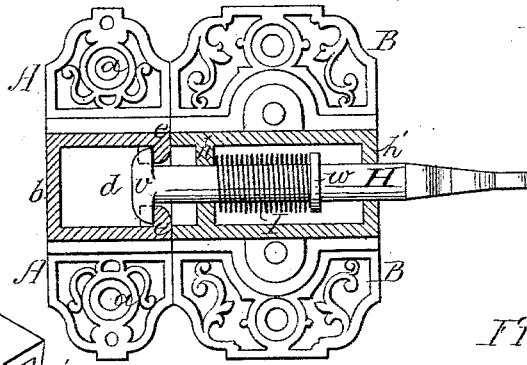

FIG. 7.

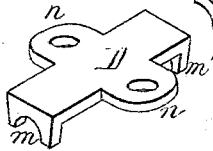

FIG. 6.

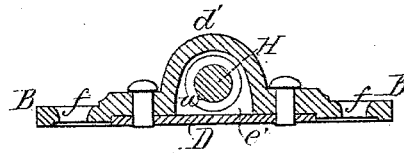
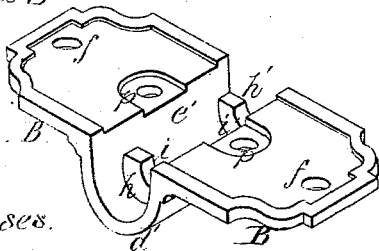

FIG. 8.



Witnesses.

Harry Smith
Henry Bowson Jr.

Inventor,

John Gerard
by his Attorneys
Howson and Son

UNITED STATES PATENT OFFICE.

JOHN GÉRARD, OF TRENTON, NEW JERSEY, ASSIGNOR TO THE TRENTON LOCK AND HARDWARE COMPANY, OF SAME PLACE.

IMPROVEMENT IN FASTENERS FOR MEETING-RAILS OF SASHES.

Specification forming part of Letters Patent No. 211,005, dated December 17, 1878; application filed October 11, 1878.

To all whom it may concern:

Be it known that I, JOHN GÉRARD, of Trenton, New Jersey, have invented a new and useful Improvement in Sash-Fasteners, of which the following is a specification:

The object of my invention is to combine a plate having a cavity and certain partitions with a plate having ribs, and with a bolt and spring, in the manner described hereinafter, so that the whole shall constitute a cheap, efficient, and neat sash-fastening block.

Figures 1 and 2 are perspective views of the lock and keeper of the sash-fastener; Figs. 3 and 4, vertical sections, showing the spring-bolt in different positions; Fig. 5, a sectional plan; Fig. 6, a transverse section; and Figs. 7 and 8, perspective views, showing the parts composing the casing of the lock in inverted positions.

A is the keeper, provided with countersunk holes *a a*, for receiving the screws which secure it to the top of the lower rail of the upper sash of a window. The keeper has an enlargement, *b*, in which is a recess or chamber for receiving the T-head of the bolt, the recess being open below, closed at the rear, and having in the front of the keeper a vertically-elongated opening, *d*, for admitting the T-head of the bolt into the recess, two shoulders, *e e*, being formed, one on each side of the opening, for the head of the bolt to catch against, as shown in Fig. 4.

It will be observed that the vertically-elongated opening passes out through the base of the keeper—an arrangement which facilitates molding, as it permits the ready withdrawal of the pattern from the sand.

The method of constructing the lock will be best understood by referring to the perspective views, Figs. 1, 7, and 8.

A cast-iron plate, B, has a transverse rounded enlargement, *d'*, on its upper surface, and a corresponding cavity, *e'*, on its under side, the plate having countersunk holes *f f*, for receiving the screws which secure it to the top of the upper rail of the lower sash of a window.

Across the cavity in the under side of the plate B extend two partitions, *h h'*, each having a semicircular recess, *i*, adapted to the bolt H; and a plate, D, Fig. 6, arranged to fit in

the cavity *e*, has two ribs, *m m'*, each having a semicircular recess. The plate has also two lugs, *n n*, adapted to corresponding recesses *p* in the under side of the plate B. When this plate D is fitted to the cavity *e* of the plate B the flanges *m m'* coincide, and are in contact, or nearly so, with the partitions *h h'*, and the recesses of the flanges and recesses of the partitions form circular openings for the reception and guidance of the bolt H. Before the bolt is put in place, however, a spring, I, is coiled around it, and this spring has its abutment at one end against a collar, *w*, on the bolt, and at its other end against the flange *m* of the plate D and partition *h* in the cavity of the plate B, the tendency of the spring being to move the bolt outward from the keeper to an extent limited by the contact of its collar with the partition *h'* and the flange *m'* of the plate D. The flange *m* of the latter plate and the partition *h* are at such a distance from the rear edge of the plate B as to form a recess for the T-head *v* of the bolt, the keeper being at liberty to be moved downward with the upper sash, or the lock being at liberty to be moved upward with the lower sash when the T-head occupies a position in this recess, as shown in Fig. 4. When the keeper and lock coincide with each other, however, (and that is when both windows are closed and the bolt is turned to the position Fig. 1,) it can be pushed rearward, the T-head passing through the vertically-elongated slot *d* of the keeper, after which, on turning the bolt one-quarter round and then releasing it, the said bolt will recoil, the projections of the T-head will be brought against the ribs *e e* of the keeper, and the two sashes will be locked together; but on giving the bolt another quarter-turn, and then releasing it, there will be a further recoil, the head escaping from the keeper, and being lodged in the recess of the lock.

There may, if desired, be notches in the inner sides of the ribs *e e* for receiving portions of the T-head of the bolt, so that the latter cannot be turned until the head is pushed far enough within the keeper to be free from the control of the notches.

The vertical and upper edges of the elongated opening of the keeper are preferably made out-

wardly flaring, and the T-head of the bolt is rounded at the ends and transversely, so that if the keeper and lock do not exactly coincide the easy entrance of the head into the opening of the keeper may be assured.

I do not desire to claim, broadly, the combination, in a sash-fastener, of a lock and spring-bolt having a T-head with a keeper adapted to the said head; but

I claim as my invention—

The within-described sash-fastening lock, in

which the plate B, its cavity *e'*, and partitions *h h'*, and a plate, D, with ribs *m m'*, are combined with the bolt H and its collar *w* and spring I, all substantially as set forth.

In testimony whereof I have signed my name to this specification in the presence of two subscribing witnesses.

JOHN GÉRARD.

Witnesses:

W. D. HOLT,
WILLIAM HOLT.