

T. HAGERTY.
Machine for Pressing and Rolling Plastic Material.

No. 211,009.

Patented Dec. 17, 1878.

Fig. 1.

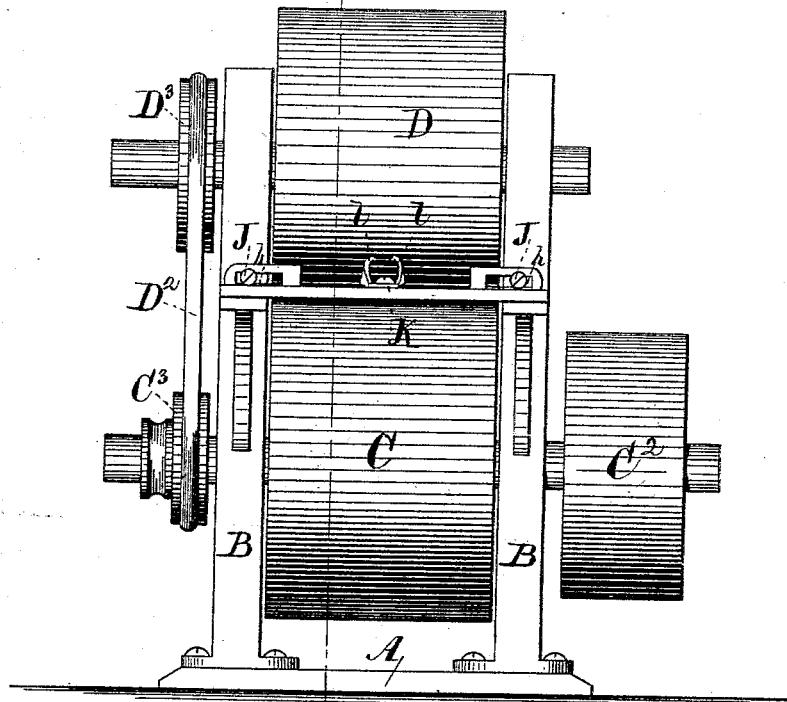

Fig. 2.

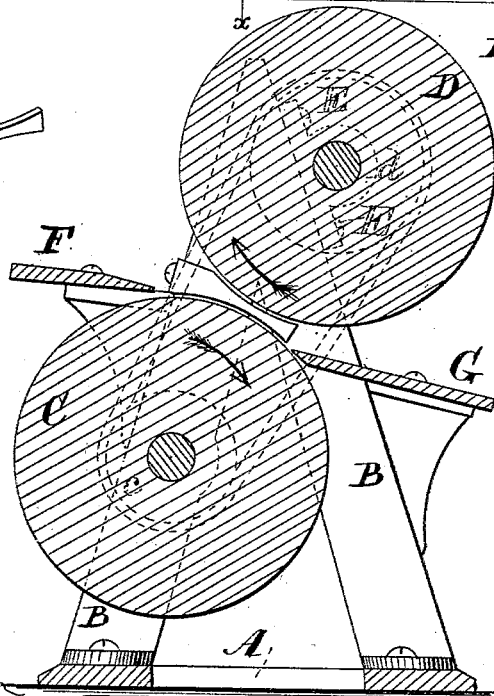
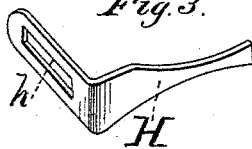

Fig. 3.



WITNESSES:

Henry N. Miller
J. J. Williamson

INVENTOR:

Thomas Hagerty,

BY E. R. Brown

ATTORNEY

UNITED STATES PATENT OFFICE.

THOMAS HAGERTY, OF BROOKLYN, NEW YORK.

IMPROVEMENT IN MACHINES FOR PRESSING AND ROLLING PLASTIC MATERIAL.

Specification forming part of Letters Patent No. 211,009, dated December 17, 1878; application filed September 17, 1878.

To all whom it may concern:

Be it known that I, THOMAS HAGERTY, of Brooklyn, in the county of Kings and State New York, have invented certain Improvements in Machines for Pressing and Rolling Plastic Material; and that the following is a full, clear, and exact description thereof.

This invention has for its object the rolling out, pressing, and forming into sticks or rods, of licorice mass or other plastic material.

The invention consists in a novel combination and arrangement with relation to each other of a pair of smooth-faced rollers running in opposite direction, and at different rates of speed, and a pair of adjustable elastic metallic strips working between said rollers, whereby the plastic material is formed into sticks or rods and the ends are smoothed off at right angles to the length.

The invention consists, further, in a novel construction of a device for centering the plastic material and delivering it to the rollers.

The accompanying drawing represents a machine embodying my improvements, Figure 1 being a front view; Fig. 2, a vertical section, and Fig. 3 a detail view.

The working parts of the machine are supported by a frame consisting of a bed-plate, A, and two standards, B B, which are of triangular form, as shown in Fig. 2.

C represents the lower roller, journaled in stationary bearings *c c* in the standards B B. To one end of the shaft of this roller is attached the driving-pulley C², and on the other end of said shaft is another pulley, C³.

D represents the upper roller, journaled in bearings *d d* on the opposite side of the frame from, and diagonally over, the roller C. The bearings *d d* are secured to the frame by means of set-screws E, passing through slots in the bearings and into the standards B. By this means the roller D may be adjusted higher or lower, so as to increase or diminish the width of the space between the surfaces of the two rollers, according to the desired thickness of the stick to be rolled. On one end of the shaft of the roller D is a pulley, D², which is larger in diameter than the pulley C³. A belt, D³, passes around the pulleys C³ and D².

A feed-board or apron, F, is secured to the front of the frame, over the roller C, and on the

opposite or rear side a delivery-board, G, is secured to the frame in an inclined or slanting position, so that the sticks may readily roll off.

H (see Fig. 3) represents the adjustable end-former, consisting of a strip of elastic sheet metal, bent at a right angle. The two edges of one of the sides of the angle are curved out to conform to and fit into the space between the surfaces of the upper roller, D, and the lower roller, C. The other side of the angle is provided with a slot, *h*.

Each machine may be provided with a number of these end-formers H, of different sizes or width, to correspond with the different widths of the space between the surfaces of the rollers C and D when the upper roller, D, is adjusted higher or lower to correspond with rods or sticks of different thicknesses, as above described.

The end-formers H H are placed in position between the rollers, and are secured to the front side of the standards B B by means of thumb-screws J J, passing through slots *h h* and entering the standards.

On the top of the feed-board F a centering and delivering device, K, is attached, consisting of a thin metallic plate, one end of which is secured to the feed-board, and the other end is formed into two wings, *l l*, which approach each other in an approximate circular form. The metal is cut away from under the wings, which leaves the sides elastic.

The two rollers C D are rotated in the same direction, and at different rates of speed, by means of the belt and pulleys above described. In practice, however, I prefer to use a small gear on roller C, and a larger gear on roller D, with an adjustable intermediate gear large enough to admit of the roller D being adjusted to and from the roller C for the various sizes of sticks. As the two rollers revolve in the same direction, the contiguous portions of their surfaces move in opposite directions.

The operation of the machine is as follows: The end-formers H H are secured at their proper distance apart to form the length of the stick required by means of the thumb-screws J J. The rollers are adjusted to allow free play for the end-formers H H, so that they may not bind. The centering device K is secured equidistant between the end-formers H

H. Motion is imparted to the driving-pulley C² in the direction of the arrows, and from pulley C³ is transmitted by the belt or gear to pulley D². Roller C travels in an opposite direction from roller D, and at a faster rate of speed. The plastic mass is fed to the machine in lumps of irregular shape, but of uniform bulk and weight. Each lump is passed through the centering device K, the wings *l l* of which, being elastic, hold the lump until it is caught by the roller C and drawn forward between the two rollers C and D. The roller C, running faster than roller D, has a drawing effect, and, as the mass revolves by the action of the rollers, it is drawn in toward the narrowest portion of the space between the surfaces of the two rollers, where it is lengthened out until its ends reach the elastic end-formers H H, where they are smoothed off at right angles to the body of the stick and delivered

on the delivery-board. The end-formers yield and accommodate themselves to any inequality in the bulk or weight of the lumps.

Having thus described my invention, what I claim as new, and desire to secure by Letters Patent, is—

1. The combination of the smooth-faced rollers C D, running in the same direction and at different rates of speed, and adjustable elastic metallic strips or end-formers H H, arranged and operating as shown and described, for the purpose specified.

2. The yielding centering and delivering device K, constructed and operating as shown and described, for the purpose specified.

THOMAS HAGERTY.

Witnesses:

C. SEDGWICK,
E. R. BROWN.