

L. HENSEL.
Milk-Boiler.

No. 211,014.

Patented Dec. 17, 1878.

Fig: 2

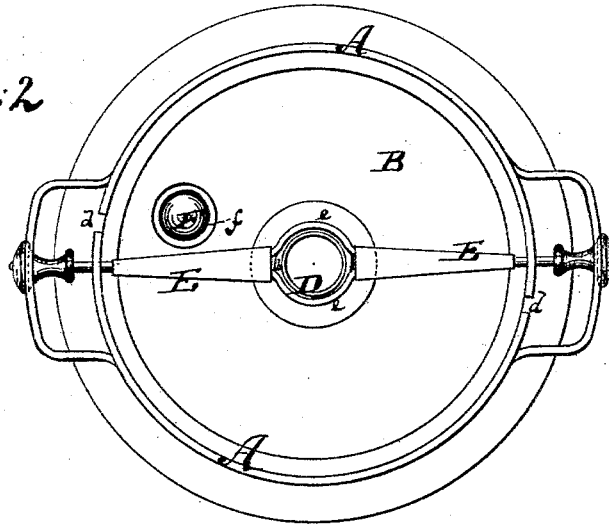

Fig: 1

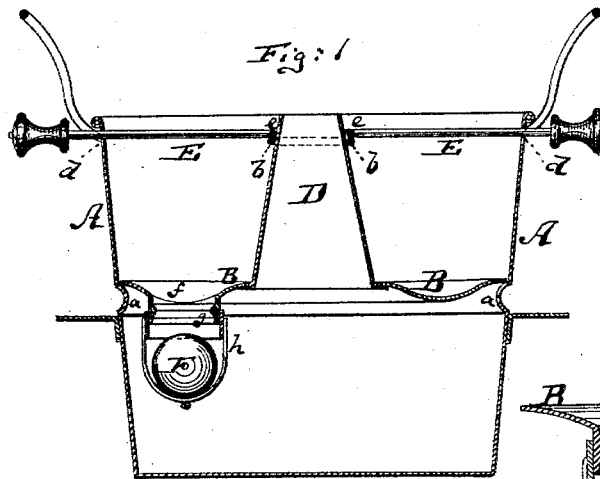
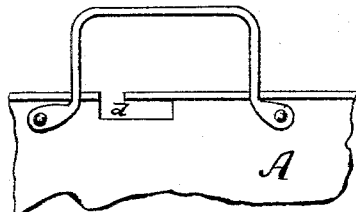
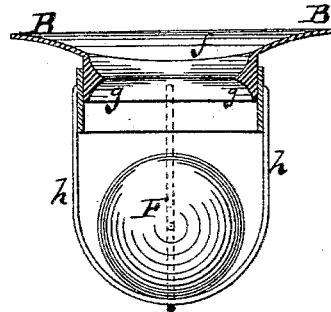

Fig: 3



Witnesses:
John C. Sunbridge
T. B. Mosher

Fig: 4



Inventor:
Louis Hensel
by his attorney
A. J. Driesen

UNITED STATES PATENT OFFICE.

LOUIS HENSEL, OF BERLIN, PRUSSIA, ASSIGNOR OF ONE-HALF HIS RIGHT
TO AUGUST KREFTER, OF SAME PLACE.

IMPROVEMENT IN MILK-BOILERS.

Specification forming part of Letters Patent No. 211,014, dated December 17, 1878; application filed
October 16, 1878.

To all whom it may concern:

Be it known that I, LOUIS HENSEL, of Berlin, Prussia, have invented an Improved Milk-Boiler, of which the following is a specification:

Figure 1 is a vertical section of my improved milk-boiler; Fig. 2, a top view thereof; Fig. 3, a detail side view of the lock thereon; Fig. 4, a detail section, on an enlarged scale, through the valve portion.

Similar letters of reference indicate corresponding parts in all the figures.

The object of this invention is to prevent milk from boiling over, even if left on the fire for an undue period, and to attain this end with the aid of a simple, inexpensive, and easily-cleaned apparatus.

The invention consists, principally, in providing the cover of the boiler with a downwardly-opening valve and with an upwardly-projecting tube, said cover being at a height below the top of the boiler, and locked by peculiar means, as hereinafter more fully described.

In the accompanying drawings, the letter A represents the body of the boiler, made of sheet metal or other suitable material. At about the middle of its height the boiler has an inwardly-projecting shoulder, *a*, which serves as a support for the movable cover B. The cover B carries at its middle portion an upwardly-projecting tube, D, which is open at both ends, and preferably of truncated conical form. The upper end of the tube D is about on a level with the upper edge of the boiler. A short distance below its upper end the tube D has an outwardly-projecting shoulder, *b*.

The rim of the boiler A is at two points, that are diametrically opposite each other, formed with L-shaped incisions *d d*. These slits or incisions serve to receive and lock the ends of a cross-bar, E, of which the central portion forms an eye, *e*, that is large enough to embrace the top of the tube D, but rests on the shoulder *b*, as shown.

The ends of the cross-bar E have suitable handles, so that it may be conveniently moved into or out of the slits *d*, to lock or unfasten the cover B, as occasion may require.

Besides the central aperture that leads to

the tube D, the cover B has another aperture, *f*, whose lower edge is formed to constitute a seat, *g*, for a float-valve, F. Said valve is contained within a wire cage, *h*, which is slid upon the annular flange that forms the valve-seat *g*, as shown in Fig. 4.

The operation is as follows: The cover B is first secured in place by means of the cross-bar E. Milk is then poured into the boiler until the portion below the cover B is wholly or partly filled. If there is much milk in the boiler, the float-valve will at once close the aperture *f*; but if the milk does not reach the valve the said aperture will remain open. As soon as the milk commences to boil and to rise it will close the aperture *f* by raising the float-valve, and will, as it can find no other escape, ascend in the tube D and flow over the top thereof into the upper part of the boiler, upon the cover B. This part of the boiler being cooler, the violent boiling action will cease therein. After enough milk shall have entered the upper part of the boiler to outweigh the floating power of the milk below, the valve F will be forced down, permitting the milk from the upper compartment to flow into the lower. The valve thereupon again closes the aperture *f*, and the boiling process continues as before.

The parts can all be readily taken apart to be cleaned. The valve-cage can be detached from the cover B to give access to the valve and valve-seat for cleaning purposes.

I claim as my invention—

1. The boiler A, combined with the cover B, having upwardly-projecting open-ended tube D and downwardly-opening valve F beneath the aperture *f*, substantially as herein shown and described.

2. The combination of boiler A, having the lock-notches *d d*, with the removable cover B, having tube D, and with the cross-bar E, for operation substantially as specified.

This specification signed by me this 21st day of August, 1878.

LOUIS HENSEL.

Witnesses:

CARL T. BURRHARDT,
AUGUST KREFTER.