

J. E. HUNTER.  
Clutch.

No. 211,019.

Patented Dec. 17, 1878.

Fig. 1.

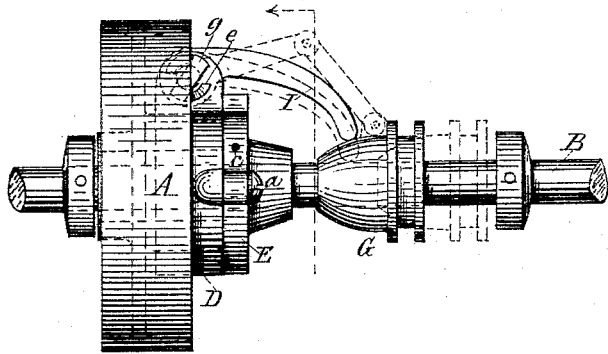

Fig. 2.

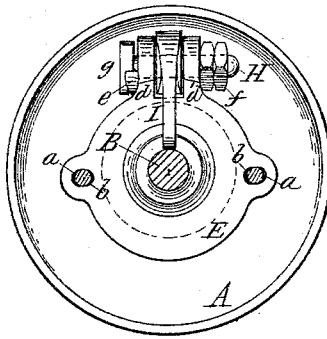

Fig. 3.

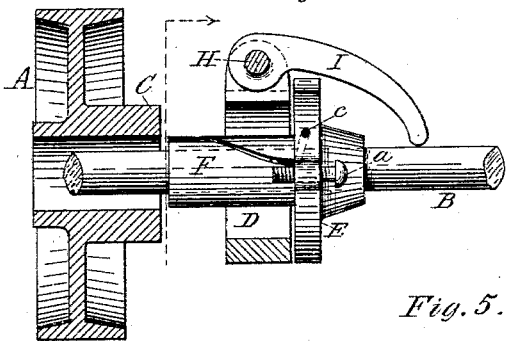

Fig. 4.

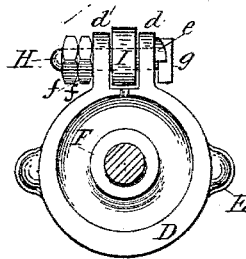
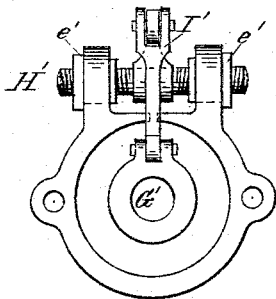

Fig. 5.



Attest:

Chas. M. Higgins.  
Edward H. Wales.

Inventor:

James E. Hunter

by his Attorneys.

S. H. Wales & Son

# UNITED STATES PATENT OFFICE.

JAMES E. HUNTER, OF NORTH ADAMS, MASSACHUSETTS, ASSIGNOR TO  
JAMES HUNTER & SON, OF SAME PLACE.

## IMPROVEMENT IN CLUTCHES.

Specification forming part of Letters Patent No. **211,019**, dated December 17, 1878; application filed  
October 16, 1878.

*To all whom it may concern:*

Be it known that I, JAMES E. HUNTER, of North Adams, Berkshire county, Massachusetts, have invented certain new and useful Improvements in Friction Pulleys and Clutches, of which the following is a specification:

My invention relates to that class of friction-clutches or clutch-pulleys which employ a friction-band; and the aim of my invention is to provide a friction-clutch pulley of this class, which shall possess a simple and durable construction, and a quick and powerful gripe, and which shall admit of the pulley being freely oiled while in motion.

The invention may be stated to consist in the combination, with a friction-band, of a tightening-screw or cam-bolt, which joins together the ends of the band, and is actuated by a projecting lever, by the operation of a sliding collar, to contract the band upon the hub, rim, or other friction-surface of the pulley, and thus effect the clutching action by a combined lever and screw motion, which gives a powerful gripe, with a slight and easy movement.

It also consists in a sustaining plate or collar fixed upon the shaft, in combination with the friction-band mounted and securely connected thereto, and arranged in such manner that the plate forms the driving-connection between the shaft and band, holds the band centrally on the pulley-hub, and permits the expanding and contracting movements thereof.

It further consists in the formation of the sustaining-plate with an elongated hub, which extends through and forms the bearing for the hub of the pulley, by which the pulley is rendered capable of being freely oiled while in motion, as hereinafter set forth.

In the drawings annexed, Figure 1 presents a side elevation of my improved friction-pulley; and Fig. 2 is an end elevation in the direction of the arrow, Fig. 1. Fig. 3 is a disarranged sectional view; and Fig. 4 is an end elevation in the direction of the arrow, Fig. 3; and Fig. 5 is an end elevation of a modification.

In the drawings, A represents a band-pulley, to which motion is imparted by a belt, as

usual, and which, for the purpose of description, may be considered the driver, while the shaft B is the part driven, although the conditions may be reversed, as will be understood. This pulley is constructed with an enlarged and extended hub, C, projecting from one side thereof, as seen best in Fig. 3, which is embraced by an encircling friction-band, D. This band is preferably cast continuous, and of substantial thickness, being first turned to a true and easy fit for the hub of the pulley, and then slit at one side, as seen best in Fig. 4, so as to be capable of being contracted or expanded upon the hub.

The pulley is loose and free to revolve upon the shaft, except when clutched thereto by the tightening of the friction-band, while the band is itself permanently fixed to revolve with the shaft by being mounted on a sustaining plate or collar, E, which is keyed to the shaft.

The friction-band is securely connected with the sustaining-plate at its diametrically opposite sides by pins or screws *a a*, which pass through slightly-elongated holes *b b* in the plate, as seen in Fig. 2, which permit the slight expanding or contracting movement of the band during the clutching or unclutching action thereof. This sustaining-plate, which is of similar outline with the band, as shown, thus forms a double and evenly-distributed driving-connection between the shaft and band, and at the same time holds the band centrally on the hub and in such manner that the band can adjust itself evenly on the hub, so as to equalize the gripe of the band over the cylindrical surface of the hub, as will be readily perceived.

The sustaining-plate is also formed with an elongated central hub, F, which projects rigidly therefrom on the same side as the band, and extends through the central bore or eye of the hub, Figs. 1 and 3, thus forming the bearing on which the pulley freely revolves. An oil-hole, *c*, extends radially through the plate, and opens into an oil-channel on the surface of the hub, as seen in Fig. 3. By this construction of the pulley-bearing, it will be seen that its relative arrangement and position is such as to permit of its being freely

oiled while the pulley is in motion, which is a point of much practical importance in this class of machinery.

The friction-band is formed at the location of the slit with radially-projecting lugs or jaws  $d' d$ , one on each side of the slit, as seen in Figs. 2 and 4, which are joined together by a tightening-screw or cam-bolt, H, a partial rotation of which one way or the other contracts or expands the band upon the pulley-hub, and thus effects the clutching or unclutching action. This bolt H is formed with a T-shaped head,  $g$ , having cam or inclined faces, which work against corresponding cam projections  $e e$  on one of the lugs of the band, as seen in Figs. 1, 2, and 4, and which consist, in effect, of segments of right and left screw-threads, preferably cast solid on the lug of the band, as shown. The opposite end of the bolt, which passes freely through the opposite lug of the band, is threaded to receive the jam-nuts  $f f$ , the screwing up of which against the lug  $d'$  adjusts the tension of the band, to render the gripe of the clutch as sensitive and as powerful as may be required; and this adjustment also allows of wear being taken up, as will be observed. This screw-bolt H is operated by a curved lever, I, which projects rigidly therefrom between the lugs of the band, and its end rests lightly upon the surface of the shaft when the clutch is released, as seen in Fig. 3.

The lever is raised to effect the clutching action by the movement of the grooved collar G on the shaft, which is operated by a forked lever, in the usual manner, as will be understood. This collar G is loose on the shaft, and is formed with a tapering or conical hub of a gently-curved outline, as shown, which, when the collar is slid forward on the shaft, wedges itself under the rounded extremity of the lever, and thus raises it by a wedging action, as shown in Fig. 1.

It will thus be seen that the friction-band is tightened on the hub of the pulley to effect the clutching action by a combined wedge-lever and screw movement, which accomplishes the contraction of the band with great power and ease.

In large clutches I prefer to modify the above-described construction slightly, by employing a toggle-lever, jointed to the sliding collar G, in lieu of the single lever I and conical wedging-collar, as seen in Fig. 5, and indicated by dotted lines in Fig. 1. In the large clutches I also prefer to employ a right and left threaded screw shaft or bolt, I', working in right and left nuts  $e' e'$ , fixed in the lugs of the band, as shown in Fig. 5, instead of the cam-headed bolt and screw-segments or cams shown in the other figures. This, however, is a simple equivalent, and may be used in either the small or large clutches, as desired.

Instead of the friction-band being formed

separate from the sustaining-plate and then securely connected therewith, it may be cast solid with the plate, but isolated therefrom at all parts, except for a portion of the circumference—say, one-eighth—so as to form a driving-connection between the two, and yet admit of the necessary expanding and contracting movement of the band; but the construction described is found best, and is preferred.

I have designed my improved clutch more especially for friction-pulleys; but it may also be used for friction-clutches in general, as may be readily understood.

The advantages claimed for my improved clutch are: a simple, strong, and durable construction; a gripe which may be adjusted to be as sensitive or as quick and powerful as may be required; an adjustment which allows for the wear of the friction-band or hub; and the readiness with which the bearing of the revolving pulley or friction-hub may be oiled while in rapid motion.

What I claim as my invention is—

1. The combination, in a friction clutch or pulley, of a friction-band securely connected with the driven or driving shaft, and having its ends joined together by a tightening-screw or cam-bolt, which is actuated by a projecting lever, by the operation of a sliding collar, to effect the clutching action of the band, in combination with a pulley or clutch-wheel, having a friction hub or surface encircled by the said band, substantially as herein set forth.

2. In a friction clutch or pulley, the combination of a pulley or clutch-wheel having a friction-hub, C, and a friction-band, D, encircling the same, with a sustaining plate or collar, E, carrying the said band and formed with an elongated hub, F, which extends through the hub of the pulley and forms the bearing therefor, substantially as herein shown and described.

3. The combination, in a friction clutch or pulley, of a friction-band, D, fixed to revolve with the driving or driven shaft, a tightening-screw or cam-bolt connecting together the ends of the band, an operating-lever, I, projecting from the said bolt, and a conical wedging-collar, G, arranged to actuate the said lever, in connection with the pulley A or clutch-wheel formed with a friction surface or hub, C, with which the band engages, substantially as set forth.

4. In a friction-clutch, the combination, with a friction-hub, C, and friction-band D, encircling the same, of the sustaining plate or collar E, keyed to the driving or driven shaft, and connected to the friction-band at diametrically opposite sides by the pins  $a a$  engaging in slightly-elongated holes in the plate, or vice versa, by which an evenly-distributed and double driving-connection is formed between shaft and band, which also allows the band to adjust itself evenly on the friction-surface when

contracted, substantially as herein shown and described.

5. In a friction-clutch, the combination, with the friction-band D and tightening-bolt H, or equivalent, joining together the end of the band, of the adjusting-nuts *ff*, arranged substantially as described, for adjusting the ten-

sion of the band, substantially as herein set forth.

JAS. E. HUNTER.

Witnesses:

SHEPHERD THAYER,  
JEREMIAH WILBUR.