

M. LOWENSTEIN.
Buttons.

No. 211,028.

Patented Dec. 17, 1878.

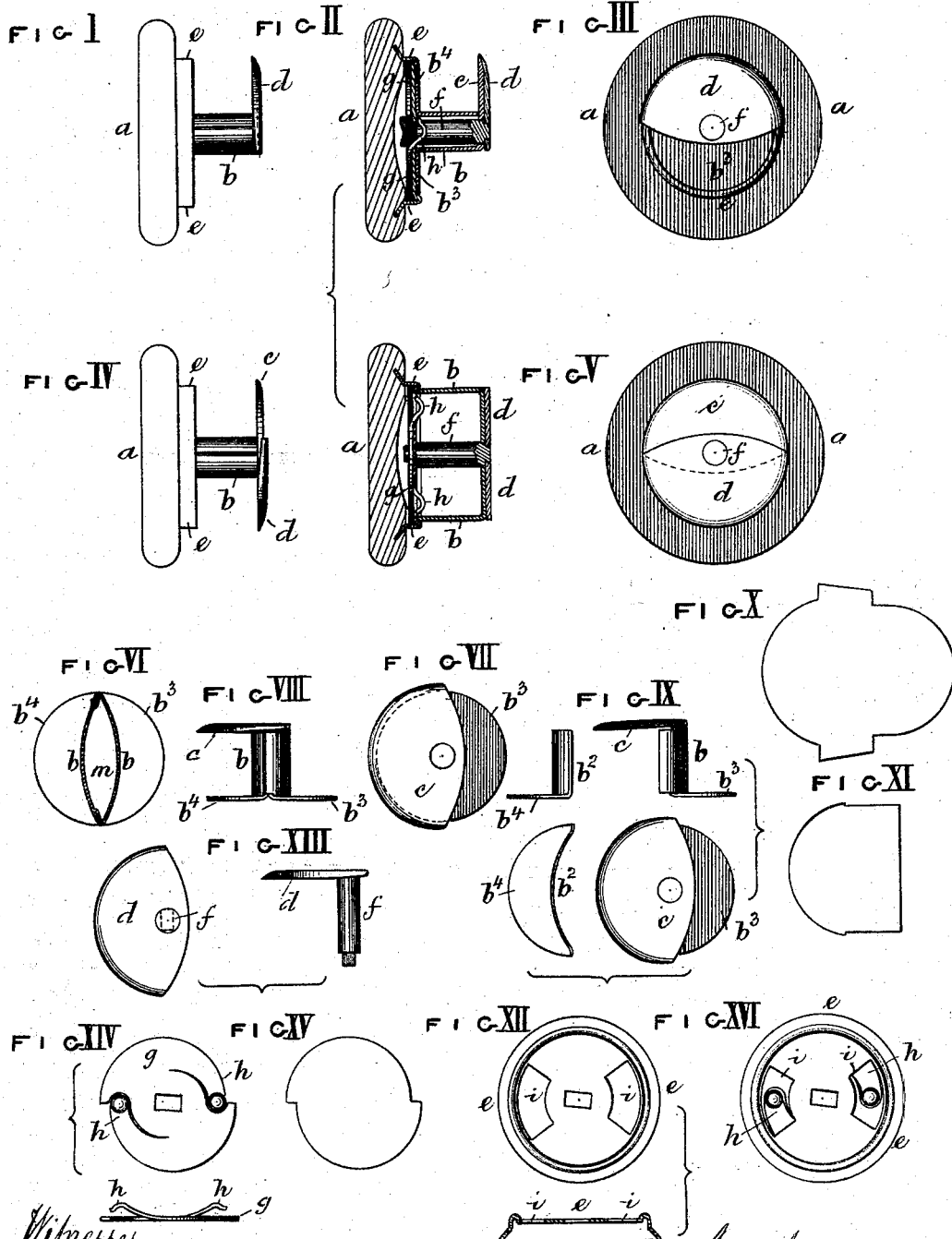

Witnesses,
George Shaw
Richard Bennett

Inventor
Martin Lowenstein

UNITED STATES PATENT OFFICE.

MARTIN LOWENSTEIN, OF BIRMINGHAM, ENGLAND.

IMPROVEMENT IN BUTTONS.

Specification forming part of Letters Patent No. **211,028**, dated December 17, 1878; application filed November 23, 1878; patented in England, September 24, 1878.

To all whom it may concern:

Be it known that I, MARTIN LOWENSTEIN, of Birmingham, in the county of Warwick, England, manufacturing jeweler, have invented new and useful Improvements in Buttons, Solitaires, Sleeve-Links, Studs, and other dress fastenings and ornaments, which improvements are fully set forth in the following specification, reference being had to the accompanying drawing.

My said invention consists in constructing the said buttons, solitaires, and other like articles in the manner hereinafter described, whereby the fastening of the button or solitaire to the article of dress is effected with great facility and the fastening is made very secure.

My invention consists, principally, in constructing the inner or back part of the button or solitaire, by which it is connected to the article of dress.

My invention has reference to those kinds of buttons, solitaires, and other like articles in which the fastening, as ordinarily constructed, consists of an oval-shaped plate or bar on the inner end of the oval shank of the button or solitaire, the said plate or bar being made to cross the button or eyelet hole in the dress to fasten the button or solitaire, and being made to coincide with and lie upon the end of the oval shank in order to unfasten the button or solitaire.

Instead of making the back fastening plate or bar in one piece, I make the back fastening plate or bar in two pieces, constructed and used in the following manner: According to my invention, I make at the inner end of the oval shank of the button or solitaire a fixed semicircular or semi-elliptical or other shaped plate or bar, the said plate or bar being situated at right angles to the said shank and forming a hook-like termination to the said shank. In front of the said fixed hook-like plate or bar of the shank is a second plate or bar of the same configuration as, and capable of motion upon, the first-named or fixed plate or bar. This movable plate or bar, by being turned through a semicircle, can either be made to lie closely upon the first-named or fixed plate or bar or be turned from off the said fixed plate or bar. When in the first-

named position the two plates or bars constitute a compound hook-like termination to the oval stem or shank of the button or solitaire, and when the movable plate or bar is turned from off the fixed plate or bar, a nearly complete circular or elliptical disk is formed at the back of the shank of the button or solitaire, and the latter fixed to the article of dress.

The movable plate or bar described is fixed by spring-tongues or by springs pressing on the axis of the said plate or bar in one or other of the two positions described, as hereinafter more particularly explained.

I will now proceed to describe with reference to the accompanying drawing the manner in which my invention is carried into effect.

Figure 1 represents a side elevation, and Fig. 2 vertical sections, the two sectional views being taken at right angles to each other, and Fig. 3 a back elevation of a solitaire of the kind described containing my improvements, the compound hook-like termination to the shank being in its unfastening position. Fig. 4 represents a side elevation, and Fig. 5 a back elevation, of the said solitaire, with the compound hook-like termination in its fastening position. The other figures represent parts of the solitaire detached, as hereinafter explained.

The same letters of reference indicate the same parts in the several figures of the drawing.

a is the front or head of the solitaire, and *b* is the elliptical or oval or angular shank of the same. At the inner end of the said oval shank *b* is a fixed nearly semicircular plate or bar, *c*, made in one piece with the said shank. The said plate or bar *c* is situated at right angles to the shank *b*, and forms a hook-like termination thereto. *d* is the second hook-like plate or bar, of the same configuration as, and capable of motion upon, the fixed plate or bar *c*. The movable plate or bar *d* can either be made to lie closely upon the fixed plate or bar *c*, as illustrated in Figs. 1, 2, and 3, or be turned from off the said fixed plate or bar, as illustrated in Figs. 4 and 5. When the two plates or bars *c* and *d* are in the positions shown in Figs. 1, 2, and 3 they form a compound hook-like termination to the stem or shank *b*, and

when in the positions Figs. 4 and 5 they form a nearly complete circular disk to the back of the shank.

The shank *b*, with its fixed hook plate or bar *c*, is represented separately in plan of under side, partly in section, in Fig. 6, and with its fixed hook-plate in plan of upper side in Fig. 7 and elevation in Fig. 8. The said shank *b* is made in two parts or halves, marked respectively *b* and *b*² in the elevation and plan, Fig. 9. The half *b* of the shank carries at the top the hook-like termination *c*, and at its bottom the nearly semicircular flange *b*³. The other half, *b*², of the shank has at its bottom a similar-shaped flange, *b*⁴, to that on the bottom of the half *b*. The half *b* of the shank is made from the blank represented in Fig. 10, and the other half, *b*², is made from the blank represented in Fig. 11. The two parts *b* *b*² of the shank are connected together by closing the ends of the said parts upon one another, so as to dispense with soldering. When thus connected together an oval shank is made having an open bottom, marked *m*, (see Fig. 6,) a circular disk, *b*³ *b*⁴, at its base, and a hook-like plate or bar, *c*, at its top.

Fastened to the back face of the head *a* of the button or solitaire, by cement or otherwise, is a circular shell or socket, *e*, (shown separately in Fig. 12,) in the face of which the circular base or disk *b*³ *b*⁴ of the shank fits. This shell or socket *e*, when the head *a* is rotated, works upon the fixed disk *b*³ *b*⁴ of the shank. The movable hook-like termination or plate *d* is connected to the socket *e* on the head *a*, and the said plate *d* is fixed in its fastening and unfastening positions, respectively, in the following manner: The movable hook-like plate or bar *d* is shown separately in Fig. 13. It is provided with an axis, *f*, which is passed through a hole in the plate or hook-like termination *c* on the shank *b*, and through the shank itself. The inner end of the axis *f* is passed through a hole in the socket *e*, and also through a hole in a disk, *g*, placed on the inner side of the said socket, and the said axis *f* is then clinched on the inside of the said disk *g*. The head *a*, socket *e*, disk *g*, and plate or bar *d* are thus connected together, so that on rotating the head *a* (the shank *b* being prevented from rotating by the eyelet-hole into which it is placed) the movable plate or bar or hook-like termination *d* is carried with it. The disk *g* on the inner side of the shell or socket *e* is furnished with two spring-tongues, *h* *h*. This disk, with its spring-tongues, is represented separately in Fig. 14, and the blank from which it is made is represented in Fig. 15. The shell or socket *e*, in combination with the disk *g*, carrying the spring-tongues *h*, is represented in plan in Fig. 16. Slots *i* *i* are made in the shell *e*, through which the free ends of the spring-tongues *h* *h* project, and press, during each semi-rotation of the head *a*, upon the under side of the disk *b*³ *b*⁴ at the open end of the oval shank *b*.

When the movable hook plate or bar *d* is in either its fastening position, Figs. 4 and 5, or in its unfastening position, Figs. 1, 2, and 3, the free ends of the two spring-tongues *h* *h* are situated opposite and snap into the open end, *m*, of the shank *b*, and firmly hold the hook plate or bar *d* in the position to which it has been brought. When the head *a* of the button or solitaire is turned for fastening or unfastening it the free ends of the spring-tongues *h* *h* are lifted from the open end of the oval shank *b*, and when the said head has been moved through a semicircle the said spring-tongues again lock the fastening by snapping into the open end of the shank.

In fastening the button, solitaire, or other article to the cuff, wristband, or other article of dress, the movable plate or bar *d* at the back of the shank is made to lie upon the fixed plate or bar *c* of the shank, as illustrated in Figs. 1, 2, and 3, and the compound hook-like termination *c* *d* to the shank is passed through the button or eyelet hole and hooked thereto by the said hook-like termination. This compound hook-like termination serves to hold the button or solitaire securely in its place while the complete fastening is being effected. Having thus hooked the button or solitaire to the button-hole, the front or head *a* of the button or solitaire is turned through a semicircle, the oval shank *b* remaining stationary in the button or eyelet hole. By this motion the movable plate or bar *d* of the compound hook *c* *d* at the back of the shank is turned nearly from off the fixed hook plate or bar *c*, so as to make the said movable plate or bar cross the button or eyelet hole on the side opposite that at which the fixed hook plate or bar *c* is situated, as illustrated in Figs. 4 and 5. The button or solitaire is thus fastened very securely to the dress. To unfasten the button or solitaire, the front or head *a* is turned through a semicircle, so as to cause the movable hook plate or bar *d* to lie upon the fixed hook plate or bar *c* of the shank. The compound hook-like end of the shank can now be withdrawn from the button-hole and the button or solitaire detached.

The compound hook-like plate or termination *c* *d* to the oval shank, constituting the essential part of my invention, may be applied to buttons, solitaires, and like articles in which the movable hook bar or plate *d* is fixed in its fastening and unfastening positions, respectively, by mechanism differing from that represented. For example, bow-springs in the hollow shank *b*, pressing on opposite sides of an angular axis, by which the movable plate or bar is fixed to the head of the button or solitaire, may be used in place of the spring-tongues represented. The said bow-springs, however, are not of my invention; and in place of the spring-tongues or bow-springs other equivalent arrangements may be substituted therefor.

Having now described the nature of my in-

vention and the manner in which the same is to be performed, I wish it to be understood that I claim as my invention—

1. In a button, solitaire, sleeve-button link, or similar article, the combination of the following elements: first, an elliptical shank of two halves, both of which are provided with semicircular flanges, to form, when united, the base-disk, while one of them has upon the opposite end a hook-like termination; second, a disk or plate held in a recess at the back of the button; third, a spindle having at one end a hook-like termination, and being secured at the other to the disk or plate at the back of the button, substantially as described, the said spindle passing through the hollow of the shank and the hook-like termination, and the plate or disk at the opposite end serving to retain the shank with the hook-like termination and base-disk in position, as set forth.

2. The combination, in a button, solitaire sleeve-link, stud, or other like article with the compound hook-like termination, one portion thereof being fixed to the solitaire or button, and the other movable, as described, of locking mechanism consisting of spring-tongues cut out of the disk or plate secured to the end of the spindle nearest the button, and adapted to engage in the hollow or recesses of the hollow shank to which the movable hook is attached, substantially as described.

3. The combination of a recessed shell or socket attached to the button or solitaire, or similar article, and slotted, as shown, and a plate provided with circumferential springs arranged to project through the slots in the recessed shell, between which and the button the said plate is located, with a spindle having a hook-like termination secured to said plate, and an elliptical shank with hook-like termination held in position on the recessed shell by the hooked end of the spindle, sub-

stantially as described, the said elliptical shank being recessed to receive the projecting ends of the circumferential springs, as set forth.

4. In a button, solitaire, or like article having a compound hook-like termination, one portion of which is fixed to the button and the other portion of which is movable, the elliptical shank with hook-like termination and base-disk formed of two parts, both being struck up out of a single sheet of metal and united by a lapped joint, one of said parts or halves having a hook-like termination, and both being provided with a semicircular flange to form the base-disk when united, substantially as described.

5. A button, solitaire, or equivalent article composed, first, of the button; second, a slotted recessed shell or socket secured at the back; third, a plate with circumferential spring-tongues formed by cutting said plate, as shown, the said plate being located between the button and the recessed shell, and the spring-tongues projecting through the slots therein; fourth, a hollow elliptical shank having a base-plate and hook-like termination, said shank being formed of two parts or halves, as shown; and, fifth, a spindle having at one end a hook-like termination, and secured at the other to the spring-plate beneath the recessed shell, substantially as described, the elliptical shank with hook-like termination and base-disk being retained in position on the recessed shell by the hook-like termination on the spindle, and locked to prevent turning by the projection of the springs into the hollow of the elliptical shank, all substantially as set forth.

MARTIN LOWENSTEIN. [L. S.]

Witnesses:

GEORGE SHAW,

RICHARD SKERRETT,

Both of 37 Temple street, Birmingham.