

H. BUCHTER.
Machine for Forming Square Chair-Legs.

No. 211,084.

Patented Jan. 7, 1879.

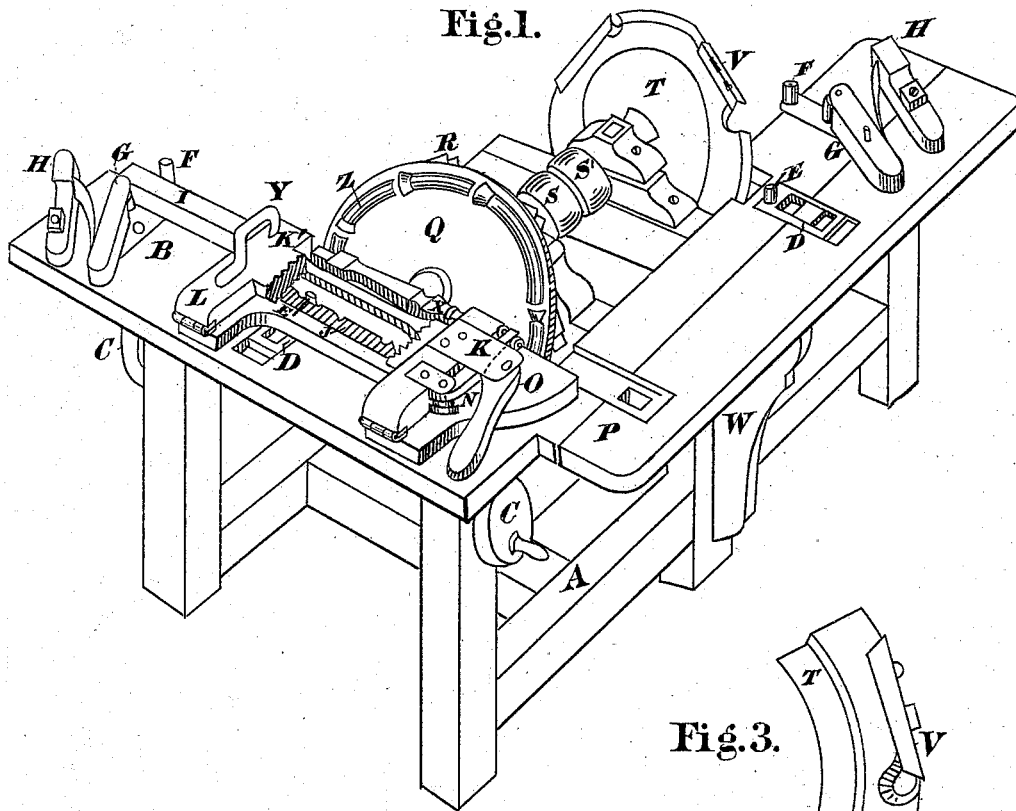

Fig. 1.

Fig. 3.

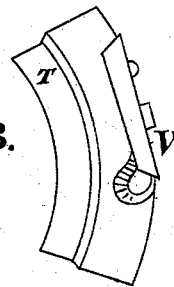

Fig. 2.

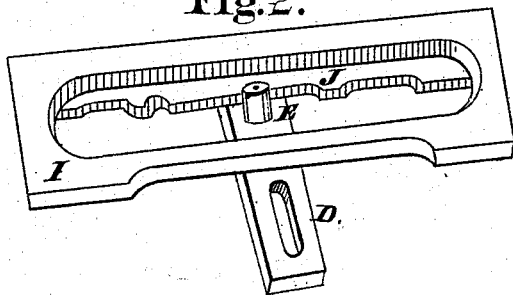
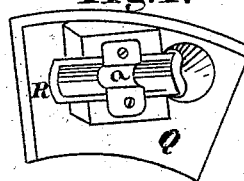

Fig. 4.



WITNESSES.

Frank Gordon.
J. S. Hewitt

INVENTOR.

Henry Buchter
by J. S. Hewitt
Attorney

UNITED STATES PATENT OFFICE.

HENRY BUCHTER, OF LOUISVILLE, KENTUCKY.

IMPROVEMENT IN MACHINES FOR FORMING SQUARE CHAIR-LEGS.

Specification forming part of Letters Patent No. 211,084, dated January 7, 1879; application filed August 24, 1877.

To all whom it may concern:

Be it known that I, HENRY BUCHTER, of the city of Louisville, in the county of Jefferson and State of Kentucky, have invented certain new and useful Improvements in Machines for Forming Square Chair-Legs; and I do hereby declare that the following is a full, clear, and exact description of the construction and operation of the same, reference being had to the accompanying drawings, forming part of this specification, and to the letters of reference marked thereon.

Figure 1 is a perspective view of the machine with the connecting-bar between the clamp-heads cut away, to show the shaping-plate under it and the roller against which it works. Fig. 2 is a perspective view of the shaping plate and roller and a part of the base-slide to which it is secured. Fig. 3 is a perspective view, showing one of the circular cutters and segment of the face-plate. Fig. 4 is a view showing the cutters for making legs with square or beveled shoulders.

This invention relates to new and useful improvements in machinery for cutting square legs for chairs; and the object of the invention is accomplished by means of cutters arranged upon a rapidly-revolving face plate or disk secured to the end of a spindle somewhat similar to an ordinary turning-lathe, with driving-pulleys between the journals.

The disk and spindle are hung in bearings on a wooden frame, the main part of which frame is made square, with one side extended sufficiently to receive an additional operating-table. The object of the provision of this additional operating-table is to adapt the machine for cutting legs with square or beveled shoulders by means of an auxiliary face plate or disk having cutters arranged on the edge to suit the required shape, whereby the necessity of removing the main or fixed disk is obviated when different designs are required. These disks, when in their bearings on the frame, are set back from the front sufficiently to give room for an adjustable table large enough to receive the operating-slide, to which the several devices for holding the leg are attached, and by means of which the leg is held in position to be operated upon. The lower side of the leg, when in the operating-

slide, rests firmly on the inner edge of the base-board or slide below, and is secured in position by clamps, in which it may be turned to be operated upon on its different sides, and at the same time be always kept square or in position to be cut to the required shape without further attention from the operator.

The machine is designed to make square work with any suitable kind of moldings.

In the drawings, A represents the frame, which is made of wood, and of substantially the form shown, with one side extended sufficiently to receive an auxiliary operating-table. B is the main or principal table, which is hinged to the frame A in such a manner as to be easily raised or lowered to cut angles. C C are eccentrics for adjusting the table, being arranged at opposite ends of the table, and connected by a shaft extended through the frame. D is a plate secured to the table by a set-screw, and carrying a roller, E, upon its inner end, against which roller a shaping-plate, J, works, by means of which form is given to the leg as it moves along against it. F is a roller for guiding the end of the base-slide I. G is a lever, with roller and spring, for the purpose of pressing the slide I against roller F, thereby holding said slide in position relatively to the cutters. H is a rest for the end of the spring, secured to the table. I is the base-board slide, to which the several devices for holding and turning the leg are attached. This slide is provided with a slot-opening in the center, beneath which the shaping-plate J is secured. The edge of this plate J is provided with the exact form of the leg to be cut, and thereby gives shape to the article operated upon as the plate is moved along against the roller E, arranged for that purpose.

K K' are the clamp-heads of the frame L, for holding the leg. This frame L is hinged to the edge of the slide I in such a manner as to be easily raised to take out the finished leg and put in another to be formed.

The leg is held firmly in this frame by means of the small pin in the clamp-head K' at one end, and by a pin in the angle end of a lever, N, at the other end, which latter pin enters a hole made in the end of the leg for connecting it with the chair when finished. This lever N is hinged to the side of the clamp-head

K, and is pressed up against the end of the leg by the eccentric end of the lever O, which is also hinged to the side of the clamp-head K, as shown.

Q is the main face plate or disk, the face side of which is made plain, except where the cutters project through, at which point a semi-circular or half-rounded bead or projection, Z, is made, corresponding in shape with the cutting-edges or cutters. R R are the cutters, which are made in the form of gouges or half-circles, and secured to the face plate or disk from its rear in grooves of corresponding shape, said grooves being made in beveled or inclined blocks on the back of the face-plate, and the cutters retained therein by straps *a*. S is the driving-pulley, by which the machinery is operated; and S', the ordinary loose belt-shipping pulley. T is the additional or auxiliary face plate or disk on the rear end of the spindle. This auxiliary face-plate is provided with adjustable and removable cutters V, whereby various configurations may be given to the legs. This face-plate operates in connection with the additional or auxiliary table P, which table is secured to, or is, in fact, the extension of, the main frame, and receives a leg clamping and

adjusting mechanism similar to that shown upon table B. W is the hinged bracket, for holding up the additional operating-table. X is the leg to be operated upon. Y is the handle of the clamp-frame.

What I claim is—

1. The slotted slide I, shaping-plate J, secured thereto, and roller E, in combination with mechanism for holding and turning the leg to be operated upon, substantially as described.

2. The base-board slide I and clamp-frame L, in combination with the adjustable plate D and shaping-plate J, substantially as described.

3. A work holding and shaping slide, I, in combination with the lever and roller G, roller F, rest H, and table B, substantially as and for the purpose described.

4. A face plate or disk, Q, provided with the bead Z, in combination with gouge-like cutters R, substantially as and for the purpose described.

HENRY BUCHTER.

Witnesses:

FRANK PARDOU,
C. HEWITT.