

C. HENRY.
Packing-Box.

No. 211,093.

Patented Jan. 7, 1879.

Fig. 1.

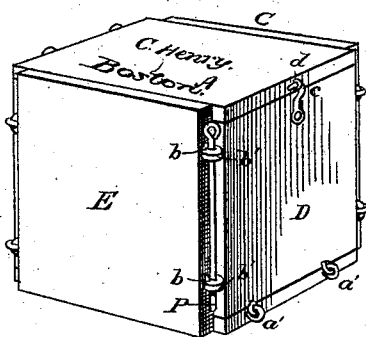

Fig. 3.

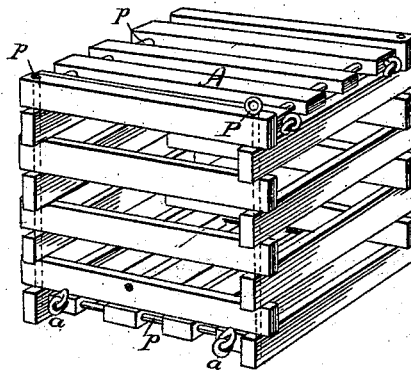
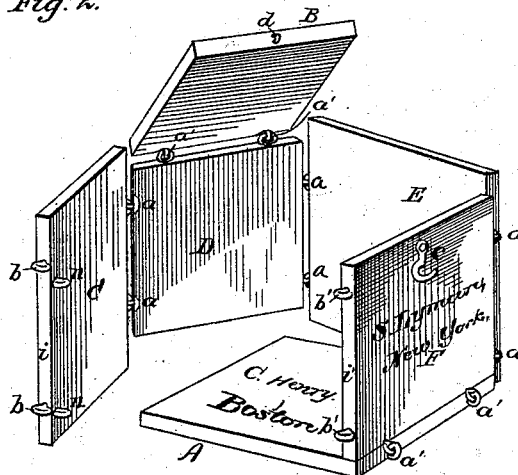

Fig. 2.



Attest:
Clarence Poole
A. K. Evans

Inventor:
Cornelius Henry
by A. H. Evans & Co.
Atty

UNITED STATES PATENT OFFICE.

CORNELIUS HENRY, OF NEW YORK, N. Y., ASSIGNOR OF ONE-HALF HIS
RIGHT TO SEYMOUR LYMAN, OF SAME PLACE.

IMPROVEMENT IN PACKING-BOXES.

Specification forming part of Letters Patent No. **211,093**, dated January 7, 1879; application filed
November 27, 1878.

To all whom it may concern:

Be it known that I, CORNELIUS HENRY, of the city and State of New York, have invented a new and Improved Packing-Box; and I hereby declare the following to be a full, clear, and exact description thereof, reference being had to the accompanying drawings, making part of this specification, in which—

Figure 1 is a perspective view of my improved packing-case closed for shipment. Fig. 2 is a view with the leaves or sides unfolded, and during the process of turning the case inside out to be reused. Fig. 3 is a modification of my device.

In the transportation of goods where two parties are shipping constantly to and from each other, the cost of packing-cases becomes a serious item of expense in the shipments.

The object of my invention is to obviate this expenditure and provide a packing-case which may be reused by two shippers until worn out.

My invention consists in a packing-case having hinged movable sides and ends, and top and bottom hinged to the structure, and so constructed that the case may be turned inside out at will and reused. One shipper has his name and address stenciled on one surface of an end or side, and the other shipper on the opposite surface, so that the names are alternately displayed as a direction as the case is turned.

In order that those skilled in the art may make and use my invention, I will proceed to describe the manner in which I have carried it out.

In the said drawings, C D E F are four pieces, forming the sides and ends of my case, and having their edges secured together by double hinges or eyes, or equivalent devices, *a*

a, so that they will fold in either direction in their relation one with another. To sides D F, at *a' a'*, are attached, by eyes or equivalent devices, two pieces, A B, which form the top and bottom of the box, and each is provided with an eye, *d*, to receive a hook, *c*, on sides D and F, to hold the ends secure. On the edges *i i'* of pieces C and F are eyes *b b'*, so located that they lap and lie coincident, so as to allow the insertion of a rod or pin, P, to secure the sides in a rectangular position. Additional eyes *n n* may be placed on side pieces, C and F, so that they will lap inside of the box, and the pin P be protected from withdrawal. When the case is made up, as seen in Fig. 1, and packed, it is secured by means of nailing a piece of strap-iron around it, or in any other desirable manner.

The modification shown in Fig. 3 is of substantially the same construction, the sides and ends being made of slats instead of being solid pieces.

Having thus described my invention, what I claim as new, and desire to secure by Letters Patent, is—

As a new article of manufacture, a reversible packing-case composed of folding sides and ends hinged together, and having a top and bottom, A B, hinged to the structure, with the name and address of the respective consignees on the opposite surfaces, and all arranged and secured so that the case may be turned inside out at will, substantially as described.

CORNELIUS HENRY.

Witnesses:

R. K. EVANS,
W. F. MORSELL.