

H. K. FAULKNER.
 Metal Mold for Casting Head to Curd-Knife.
 No. 211,140. Patented Jan. 7, 1879.

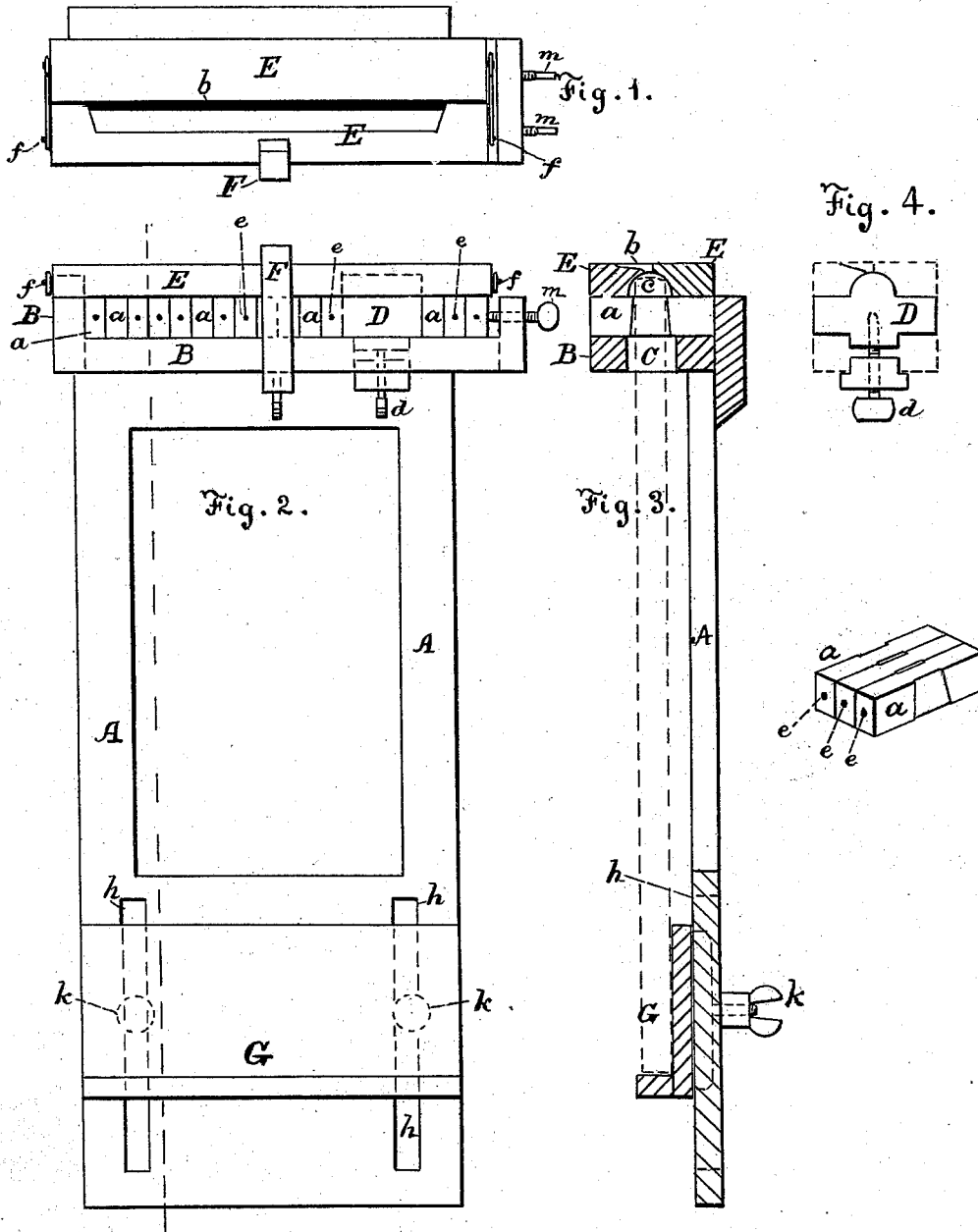

Witnesses:
W. Burris
H. A. Daniels

Inventor:
Horace K. Faulkner
 By *J. S. Kitzly*
 Attorney.

UNITED STATES PATENT OFFICE.

HORACE K. FAULKNER, OF UTICA, NEW YORK, ASSIGNOR TO HIMSELF,
CHANDLER D. FAULKNER, AND FRANK L. JONES, OF SAME PLACE.

IMPROVEMENT IN METAL MOLDS FOR CASTING HEADS TO CURD-KNIVES.

Specification forming part of Letters Patent No. **211,140**, dated January 7, 1879; application filed July 10, 1878.

To all whom it may concern:

Be it known that I, HORACE K. FAULKNER, of Utica, in the county of Oneida and State of New York, have invented certain new and useful Improvements in Molds used in the Manufacture of Curd-Knives and similar articles; and I do hereby declare that the following is a full, clear, and exact description thereof, which will enable others skilled in the art to which it appertains to make and use the same, reference being had to the accompanying drawings, and to letters of reference marked thereon, which form a part of this specification.

This invention relates to molds used in the manufacture of knives for cutting curds in the course of the operation and process of making cheese; and consists in certain improvements in the construction of such molds, as herein-after more fully shown and described.

In the drawing referred to as forming a part of this specification, Figure 1 is a top view of the improved mold. Fig. 2 is a side view of the same. Fig. 3 is a vertical longitudinal section. Fig. 4 represents the sliding block D and its clamp, herein described.

A designates a frame, to the upper end of which is fixed, at right angles to the frame, a support or seat, B, which is intended to hold a number of blocks, *a*, and other parts forming the mold. The blocks *a*, being of uniform size and thickness, are slightly recessed across their sides, so that when placed together in a row narrow openings are left between them, through which the ends of the blades to form the curd-knife may be passed. The blocks are also provided with holes *e* at each end, so that a rod or piece of wire may be inserted to remove the blocks when they are heated.

The part B has also a slot or opening, C, through which the blades pass, and in which opening partially extends a sliding block, B, provided with a clamp having a thumb-screw, *d*, to fix the block D in any position along the slot C. The block D has a projection on its upper side conforming to the chamber *c*, and to extend therein, (see Fig. 4,) to form one end of the chamber, the other end of the chamber being closed by a similar projection on the support B.

Two pieces (indicated by E) are rabbeted or grooved, as shown, so that when placed to-

gether on the top of the frame and resting on the blocks *a* and the support B, they form a chamber, *c*, into which the ends of the blades extend. A narrow opening, *b*, is also provided, through which the melted metal is poured; and the parts E are secured together by means of the hooks and studs *f*.

A clamp, F, serves to hold the parts E to the support B.

The lower part of the frame A is provided with an adjustable rest, G, for the lower ends of the blades when they are placed in position on the frame, the latter being provided with vertical slots *h*, through which pass screws from the rest-board G, so that it may be clamped to the frame at the desired height by means of the thumb-nuts *k*.

In adjusting the mold a number of the blocks *a* are placed in their seat in the part B, and the sliding block D is placed in the seat against the last block in the row, and clamped in place by means of the screw *d*. The remaining space in the seat may be filled up with other blocks *a*, which may be closed together by means of the screws *m*. The blades to be secured together are then placed in a vertical position, with their lower ends on the rest G and their upper ends extending through the openings formed between the blocks *a*, first mentioned, into the chamber *c*, and the mold-pieces E are placed in position on top, hooked together, and clamped to the supporting part B. The melted metal is then poured into the chamber *c* through the mouth or opening *b*.

Having described my invention, I claim—

1. The recessed parts E and perforated blocks *a*, the latter having their sides recessed, in combination with the support B, having slot C, as herein set forth.

2. The frame A, having the slotted support B to receive the blocks *a*, in combination with the recessed parts E and the block D, provided with a clamp, as herein specified.

In testimony that I claim the foregoing as my own I affix my signature in presence of two witnesses.

HORACE K. FAULKNER.

Witnesses:

J. ARTHUR JONES,
ARNOLD SONDEREGGER.