

C. W. GLIDDEN.
Lasting-Machine for Boots and Shoes.
No. 211,148. Patented Jan. 7, 1879.

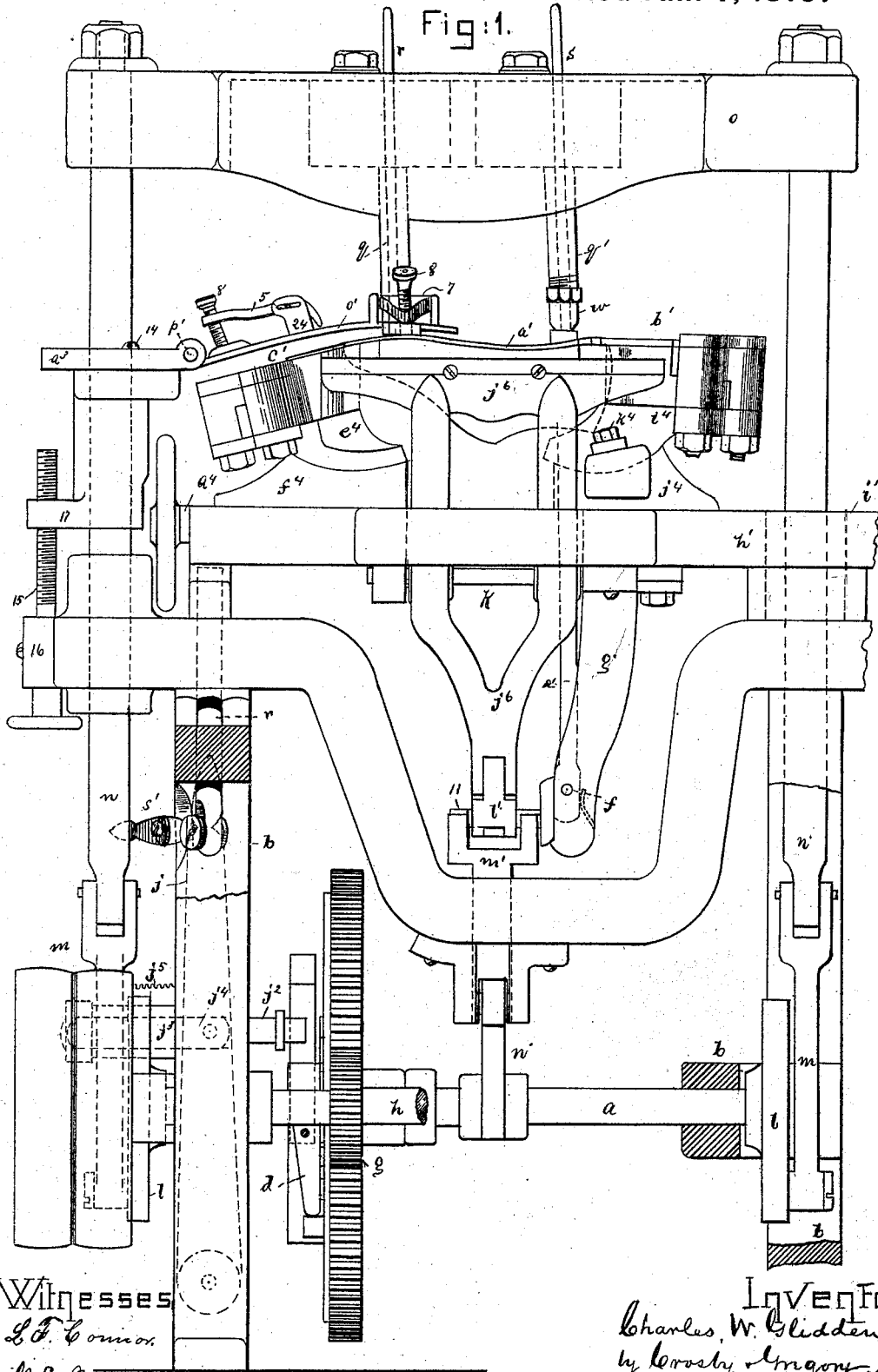

Witnesses
L. F. Connor.
N. E. Whitney.

Inventor
Charles W. Glidden,
by Henry Morgan Atty

C. W. GLIDDEN.

Lasting-Machine for Boots and Shoes.

No. 211,148.

Patented Jan. 7, 1879.

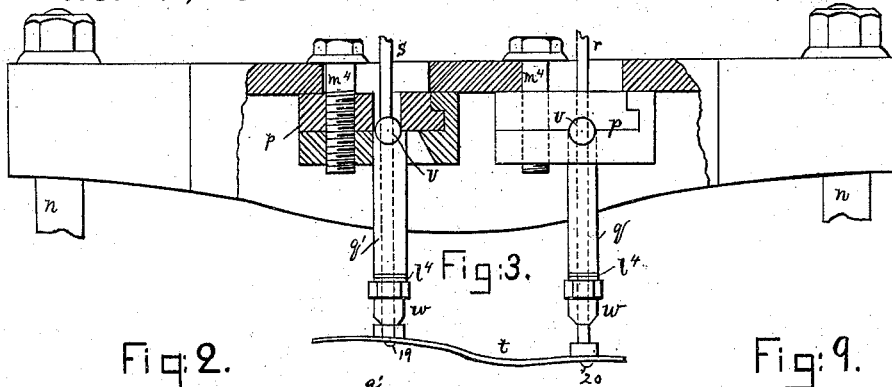

Fig: 2.

Fig: 3.

Fig: 9.

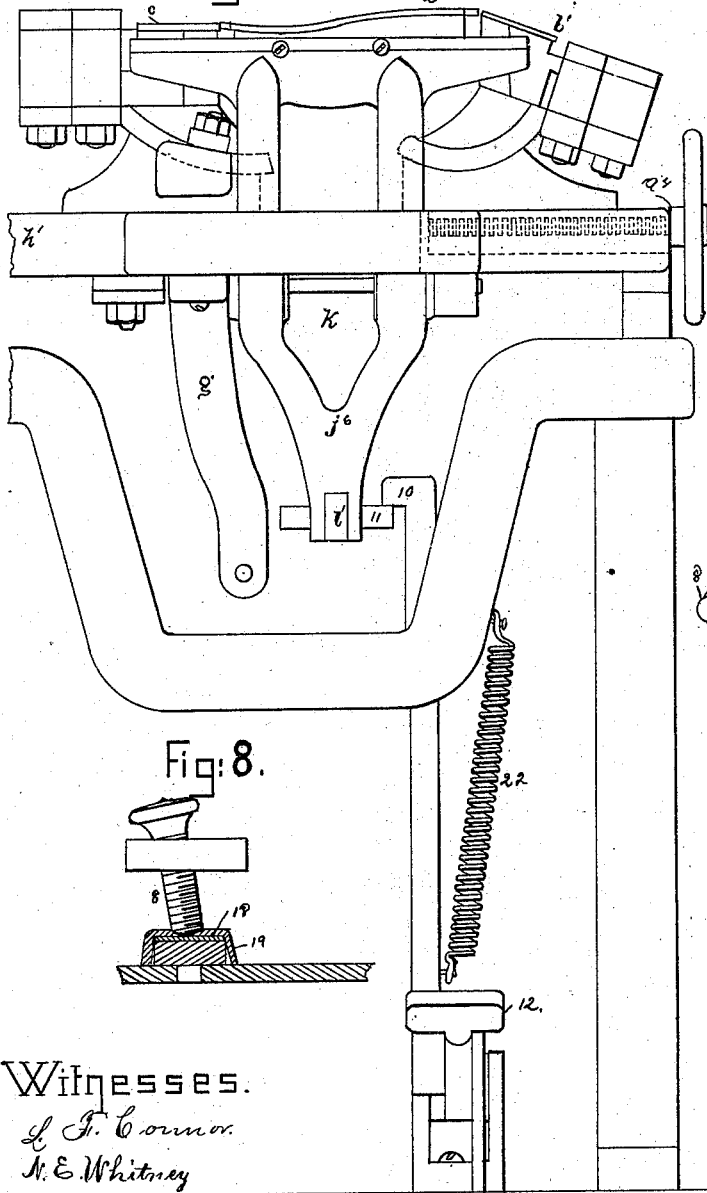

Fig: 8.

Fig: 4.

Witnesses.
L. J. Connor.
N. E. Whitney

Inventor.
Charles W. Glidden
by Crosby & Morgan Atty.

C. W. GLIDDEN.

Lasting-Machine for Boots and Shoes.

No. 211,148. Patented Jan 7, 1879.

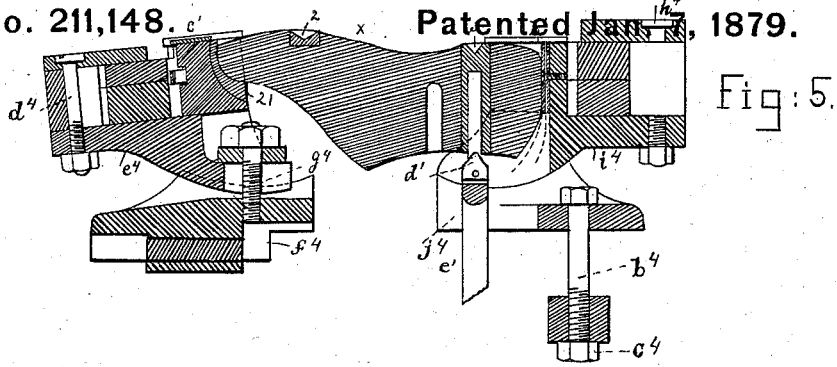

Fig:5.

Fig:6.

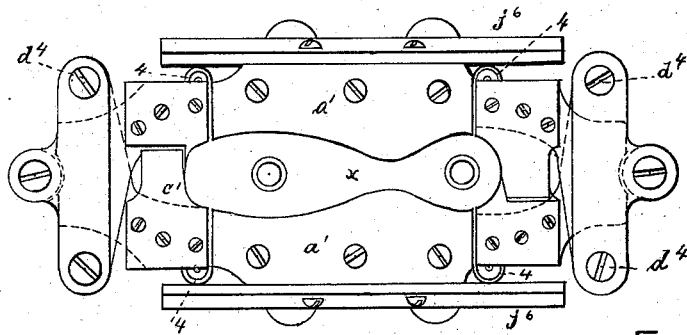
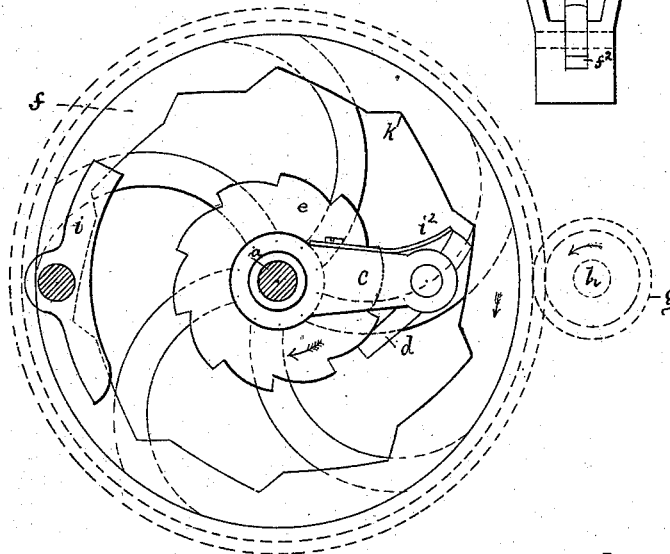
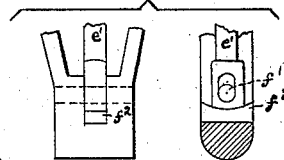

Fig:7.

Fig:10.



Witnesses.
L. F. Connor.
N. E. Whitney.

Inventor
Charles W. Glidden
by Crosby & Ingony Atty's

UNITED STATES PATENT OFFICE.

CHARLES W. GLIDDEN, OF LYNN, MASSACHUSETTS.

IMPROVEMENT IN LASTING-MACHINES FOR BOOTS AND SHOES.

Specification forming part of Letters Patent No. 211,148, dated January 7, 1879; application filed November 29, 1878.

To all whom it may concern:

Be it known that I, CHAS. W. GLIDDEN, of Lynn, county of Essex, State of Massachusetts, have invented an Improvement in Lasting-Machines for Boots and Shoes, of which the following description, in connection with the accompanying drawings, forming a part thereof, is a specification.

This invention has reference to improvements in machines for lasting boots and shoes.

The machine has a rotating head, provided with a double set of heel and toe and side lasting or crimping jaws, or equivalent devices, to crowd the upper about the edge of the inner sole placed on the last-bottom.

When one operator manipulates the machine to fit the upper to the last, another operator secures the upper and inner sole of a shoe previously lasted, and then removes the last and shoe.

The upper is held stationary by suitable upper-holding devices adapted to grasp its edges, and then the last and upper are pressed together until the upper is made to fit the last snugly, and then the jaws or lasting devices move toward the last and push or crowd the upper over the inner sole and last-bottom, while the upper is held by the upper-holding devices.

When the strain upon the upper is sufficient to lay it snugly in contact with the last, the upper-holding devices are made to automatically release it.

The inner sole is shown as adapted to be placed in position upon the last by adjustable pins, which enter holes in the inner soles, and also in the bottom of the last.

Figure 1 represents, in side elevation, part of a lasting-machine constructed in accordance with my invention. Fig. 2 represents the part broken away from Fig. 1. Fig. 3 represents a detail of the walking-beam to operate the sole-plate, and the pressers or down-holds to force the last downward at its fore and rear parts; Fig. 4, a view of one form of plate and upper-holding device to hold the upper at its edges; Fig. 5, a longitudinal section through the last, and heel and toe lasting devices; Fig. 6, a top view of the lasting devices, showing the side-lasting jaws and heel and toe lasting jaws closed about the last; Fig. 7, a detail of

the rotating ratchet-wheel, to intermittingly operate the main shaft of the machine; Fig. 8, a detail of an upper-holding device and a yielding spring to permit it to release the upper at the proper time. Fig. 9 represents a modified form of side and shank lasting devices, it showing a series of adjustable fingers to crowd the upper over the last at the side and at the shank; and Fig. 10, a detail of the lower end of the rod to which the last-holding pin is pivoted.

The main shaft *a*, mounted in the frame *b*, of any suitable construction, has an attached arm, *c*, provided with a pawl, *d*, which is acted upon to drive the shaft *a* at the proper times by a shoulder, *k*¹, of a ratchet-wheel, *f*, placed loosely upon the shaft, but driven at all times positively by a pinion, *g*, on a shaft, *h*, provided with a fast and loose pulley of ordinary construction. This pawl is disengaged at each revolution of the shaft *a* by means of a pawl-lifter, *i*, that, striking the short end of the pawl, moves it out of engagement from notch *k* and against the pressure of the spring *i*². This pawl-lifter *i* is attached to a rod, *j*², extended through a bearing, *j*³, the rod being connected by a link, *j*⁴, with a slipper, *j*, the latter and the link being shown in dotted lines, Fig. 1. A spring, *j*⁵, moves the rod *j*² toward the wheel *f*.

The pawl-lifter may, when desired, be moved laterally from contact with the pawl, and then the pawl will rise under the action of the spring *i*², and the wheel will again engage it and move the shaft.

The shaft *a* has two disks, *l*; but they might be cranks or eccentrics, connected by links *m*, with rods *n* attached at their upper ends, with the opposite ends of a walking-beam, *o*, provided at or near its center with adjustable boxes *p*, containing the pivots *v* of the pressers or down-holds *q*, having within them, as therein shown, sliding rods *r*, which, at their lower ends, carry a sole-plate, *t*.

The rods *r* *s* are held within the pressers *q* with sufficient friction to prevent them from descending unless moved positively.

The lower ends of the rods extend sufficiently far through holes in the sole-plate to permit the inner sole to be impaled upon the ends 19 20 of such rods, they constituting

pins to hold the inner sole. When an inner sole is placed upon these pins the sole-plate is drawn down by hand until the ends of the rods enter holes 2 3 in preferably metallic centering-blocks set in the last-bottom x . (See Figs. 5 and 6.) The pins entering such holes correctly place the inner sole upon the last, and hold it there until after the devices that push the upper over the inner sole pass a little way over the edge of such inner sole.

The block 3 is herein shown as prolonged through the last, where it is provided with a hole to receive the last-pin d , pivoted upon a supporting-rod, e^1 , having its pivot at f^1 . The lower end of this rod, slotted to receive the pivot f , rests upon an india-rubber or other spring, f^2 , (see Fig. 10,) to permit the rod to descend a sufficient distance to insure the descent of the inner sole and last far enough to permit the lasting devices to pass over the edge of the inner sole. Inner soles vary in thickness, and this spring f^2 compensates for this variation.

The rod e^1 has its pivot in a hanger, g^1 , connected with a rotating head, h^1 , pivoted on a vertical pivot, i^1 , in this instance made hollow for the passage of the rods n . This head carries at each end lasting devices, of usual construction, to crowd the upper at the-sides, and shank, and heel and toe of the shoe over upon the inner sole.

In Figs. 1, 2, the jaws j^6 are pivoted at k , and connected at their lower ends by a toggle-lever, l , having an elongated connecting-pin, 11.

The jaws j^6 in Fig. 1 are provided with curved plates $a^1 a^1$, to perform the side and shank lasting. Instead of these plates the jaws may be provided with a series of adjustable fingers, x^3 , as shown in Fig. 9, and fully described in another application made by me, and filed April 30, 1877, to which reference may be had. These fingers x^3 will preferably be used. They are slotted, and bear upon the upper to crowd it over the edge of the inner sole. They are made adjustable horizontally and vertically, to adapt them to the varying curvature of the sole and last-bottom.

The toe and heel lasting devices are represented at $e^1 b^1$. They are composed each of two blades, one overlapping the other, and carried by pivoted arms. Each arm has a friction-roller, 4, which is struck by the upper ends of the jaws when they are closed. The side jaws in closing move the toe and heel lasting jaws to crimp the heel and toe of the upper over the last.

The two lasting-jaws are pivoted at d^4 upon a rest-plate, e^4 , adjustably connected with the base f^4 by means of a screw, g^4 , and this base is made adjustable horizontally by means of a screw, a^4 .

The heel-lasting jaws, pivoted at h^4 upon a rest-plate, i^4 , are adjustably connected by screws k^4 with the base j^4 , made adjustable on the frame h^1 by means of suitable bolts b^4 and screws c^4 .

The adjustments of the heel and toe lasting

jaws horizontally permit them to operate upon lasts of different lengths, and the adjustment between the rest-plates and their bases permits the jaws to adapt themselves to lasts of different curvature.

The block a^3 is adjustably connected, by screws 14, with an adjustable collar, 17, adapted to be raised or lowered by a screw, 15, in a part, 16, of the frame. This block a^3 is so made adjustable that it may place the pivot p' of the plate o' in proper position with reference to the lasting devices. This plate o' has the upper-holding devices 5 6 7, made as levers or dogs, controlled by screws 8 or eccentrics or toggles, so as to engage the edges of the upper, and hold the upper at the toe and ball part of the vamp firmly while the last is operated upon by the pressers at points each side of a line drawn transversely across the last, said pressers acting, the one q as a fore-part presser or down-hold, it operating upon the last or inner sole at or near the toe thereof, and the one q' as a back-part presser, it operating upon the last or inner sole at or near the heel ends thereof. These upper-holding devices are adapted to hold the upper with a certain amount of force, and then to yield and release the upper. In this instance, the screws rest against spring-pressed plates 18, held up by springs 19. (See Fig. 8.)

The upper-holding devices are made adjustable horizontally in their brackets 24 by means of elongated slots therein, (see Fig. 1,) which permits them to be moved forward over the upper laid upon the plate o' , which is handier than to draw the upper under their ends.

It is obvious that the standards 24 might be made adjustable on the plates, instead of moving the upper-holding devices in the slots of the standards.

The toe-seat of the toe-lasting device is lined with india-rubber, as at 21, to permit the last to descend the proper distance, notwithstanding variations in the thickness of the uppers.

The ratchet e , fixed to the side of the wheel f , if engaged with the long end of the pawl d , may be made to move the shaft a when its motion is to be reversed to turn the machine back.

In operation the upper is grasped or seized by the upper-holding devices. The last is placed within the upper. The sole-plate, with an inner sole applied, is drawn down until the ends of the rods enter the holes in the blocks 2 3. In this position the toe of the last is ahead of the position it will occupy at the completion of the lasting operation, and the pressers $q q'$ are substantially vertical. Now, the machine is started. The walking-beam o descends until the ends of the pressers or down-holds $q q'$ meet the sole-plate, and then the farther descent of the beam and pressers crowds the last down into the upper held by the upper-holding devices.

The pressers $q q'$ are independently adjustable laterally by means of the bolts m^4 , and vertically adjustable by moving the end por-

tions w along the screw portion l^2 , which permits both the toe and heel or fore and back part of the last-bottom to be pressed to the proper level with relation to the movement of, and hold such last in correct position for the operation of, the jaws or fingers, which crowd, fit, or stretch the upper about the last and inner sole. As the last is pressed down it is crowded backward by its action against the upper held by the upper-holding devices. The pressers turn on the pivots v during this backward movement of the last and assume an inclined position. When the upper has been strained sufficiently to fit it closely to the last the side and heel and toe lasting devices are made to approach the last and press the upper just over the edge of the inner sole. At this time, or later, the upper-holding devices may release the upper, according to the amount of strain to which it is desired to subject the material, this being governed by the quality of the material, its thickness, and the closeness of the lasting. Just as the lasting devices pass over the edge of the last the plate and pressers are raised from contact with the inner sole by the rising of the walking-beam, and then the lasting devices are completely closed.

The jaws j^6 are closed by the action of a forked slide, m^1 , lifted by a cam, n^1 , on shaft a , the fork of the slide engaging the pin 11 and straightening the toggle l^1 .

When the sole-pressers are lifted and the jaws are closed, the rotation of the shaft is stopped by the pawl-lifter i . The bolt r , connected with the lever s^1 , is then withdrawn, unlocking the head h^1 , so that it may be rotated to bring its opposite end in position under the walking-beam and sole-presser to receive another upper.

The end of the head containing the jaws that hold the shoe-upper and inner sole just operated upon is, by the rotation of the head, brought to the opposite side of pivot v^1 , or into the position shown in Fig. 2.

Referring to Fig. 2, it will be seen that the pin 11 of the toggle-joint stops under the hook 10, connected with the treadle 12, and is held up by a spring, 22. A second operator at this end of the head secures the upper and inner sole by suitable fastenings, nails, or pegs, and then depresses the lever, causing the hook 10 to spring the toggle and permit the jaws to move away from the upper, so that the lasted shoe may be withdrawn from the machine. In this way one operator may fit the upper to the last, and then rotate the head for another operator to secure the upper and inner sole together, and withdraw the lasted shoe, leaving the jaws ready to again receive an upper and last within them. The upper is drawn about the toe very closely, the slight backward motion of the last away from the dog 5 assisting in this operation.

The upper-holding devices will preferably release the upper just as the lasting devices begin to crowd the upper over the inner sole.

The toe and heel lasting devices are made longitudinally adjustable to adapt them to lasts of different lengths, and in the arc of a circle to adapt them to lasts of varying slopes at heel and toe, substantially as in the American lasting-machine. The side jaws may be provided with india-rubber faces, as in the American lasting-machine.

Considerable pressure has to be exerted to properly crowd the last into the upper held by the upper-holding devices; and it is quite essential to the complete and perfect operation of the machine that each end of the walking-beam be operated positively so as to place the last in proper position for the passage of the jaws or fingers over the last and inner sole. If the head should spring the last-bottom would not be placed in correct position. A walking-beam raised and lowered at one end only might be used; but it would have to be made heavier than if operated at both ends, which would unnecessarily increase the weight of the beam and the power required to operate the machine.

The fore and back part pressers q, q' may operate directly upon the inner sole resting upon the last to place it in correct position, as described, and the sole-plate may be omitted. The pressers move vertically to and from the last-bottom, and press it down at each end upon the support of the last, the presser and support co-operating to place the last-bottom, whatever may be its curvature, in proper relation with reference to the path of movement of the lasting devices.

It is obvious that the pressers would operate to place the last-bottom at the proper level in a machine in which the last was stationary, and the lasting jaws or devices which operated upon the upper to fit it to the last had a rising and falling motion.

From the above description it will be observed, at the commencement of the lasting operation, that the last-bottom occupies a position above the horizontal plane of movement of the side-lasting devices; that the upper is grasped and held at its edges by upper-holding devices placed substantially at the level of, or just above, the line of the horizontal or closing-in movement of the side-lasting devices; and that the last and side-lasting devices are then so moved, one with relation to the other, vertically as to place the bottom of the last and inner sole thereon in a plane below the lasting portions of the side-lasting devices, after which the side-lasting devices are moved toward the center of, and horizontally over, the bottom of the last and inner sole, crowding the edges of the upper over upon the inner sole, the heel and toe lasting devices also crimping the heel and toe of the upper over upon the heel and toe ends of the inner sole.

In this application I have shown and described certain fore and rear part down-holds and upper-holding devices; but I do not herein broadly claim either of the said devices or their combination, for the said devices are con-

tained and claimed in another application made by me and filed in the United States Patent Office, April 30, 1877.

I claim—

1. In a lasting-machine, the adjustable pins to hold the inner sole to enable it to be placed upon the last, substantially as described.

2. The pins and sole-presser, combined with rocking sleeves, to operate substantially as described when pressing the last upon the upper.

3. The adjustable pins and sole-presser, in combination with a last provided with sockets to receive the pins, substantially as described.

4. In a lasting-machine, fore and back part pressers to place a last-bottom in proper position with relation to lasting devices or jaws, combined with mechanism to adjust the toe or heel lasting jaws, or both of them, horizontally, to adapt them to lasts of varying lengths.

5. In a lasting-machine, the combination, with a pivoted last-holder and last, of mechanism to hold the upper, and mechanism to press the last down into the upper, the last moving horizontally downward and backward, substantially as described.

6. In a lasting-machine, the combination, with a last and upper-holding device to hold the upper at its edges, of independently-movable side-lasting devices and toe-crimping jaws, or slides interposed between the upper-holding devices and the edge of the last to force about the edge of the inner sole the upper, it having been sufficiently stretched, substantially as described.

7. In a lasting-machine, a rotating head and two sets of lasting devices, adapted to crowd the upper horizontally over the bottom of the last, one set being in position to be operated

to fit the upper to the last and inner sole when the other is in position to permit the upper and inner sole, held by the lasting devices, to be secured together preparatory to removing the lasted shoe from the machine, substantially as described.

8. In a lasting-machine, the vertically and horizontally movable rods *r s*, adapted to receive upon their ends the inner sole and place it upon the last, combined with fore and back part down-holds, substantially as described.

9. The sole plate or presser, combined with pivoted fore and back part pressers or down-holds, to operate substantially as described.

10. In an organized lasting-machine provided with fore and back part down-holds and shank and toe and heel lasting devices, the combination, with the main shaft, of mechanism under the control of a treadle to set a shaft in rotation, and mechanism to automatically stop the rotation of such shaft after each rotation, substantially as described.

11. In a lasting-machine, the combination, with toe and side lasting devices to crowd the edges of the upper over upon the inner sole, of pivoted pressers or down-holds, adapted to bear upon the inner sole at the front and rear part of the last, and move backward with the last as it is being fitted closely into the upper, substantially as described.

In testimony whereof I have signed my name to this specification in the presence of two subscribing witnesses.

CHARLES W. GLIDDEN.

Witnesses:

L. F. CONNOR,

N. E. WHITNEY.