

J. RUSSELL & A. BEMIS.
Card-Setting Machine.

No. 211,186.

Patented Jan. 7, 1879.

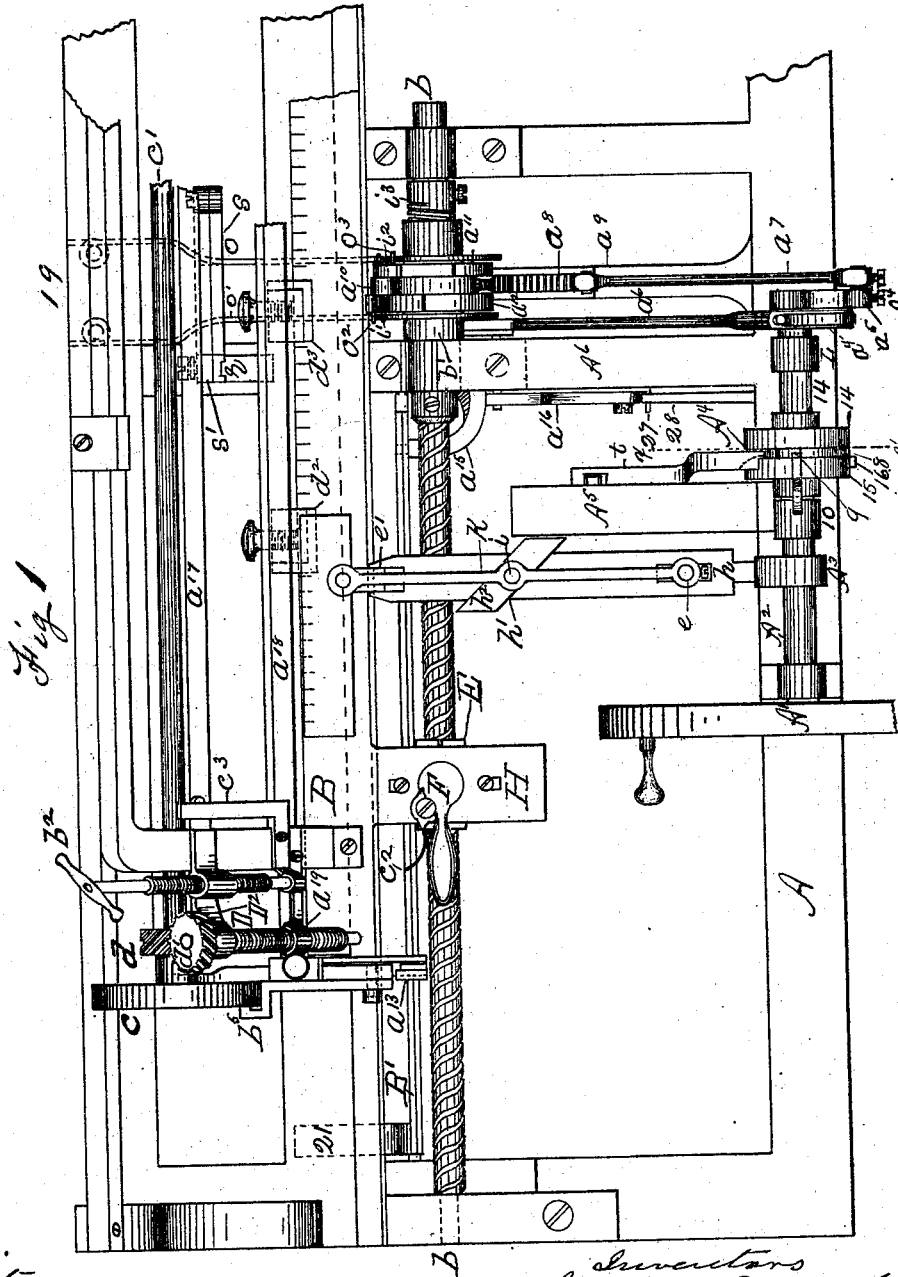

Mitresses
Ho A Chapin
Wm A Chapin

Inventors
James Russell,
Austin Bemis,
By Chapin &
Atty.

J. RUSSELL & A. BEMIS.
Card-Setting Machine.

No. 211.186.

Patented Jan. 7, 1879.

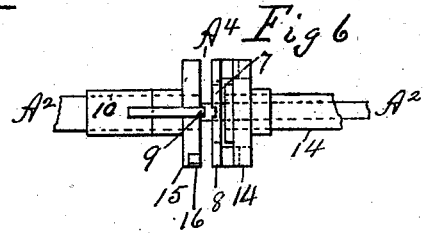
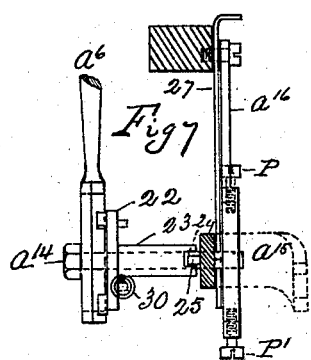
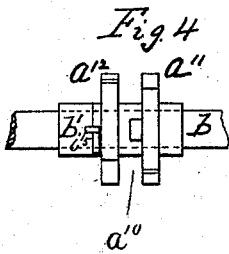
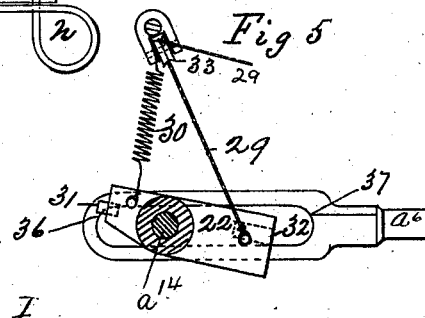
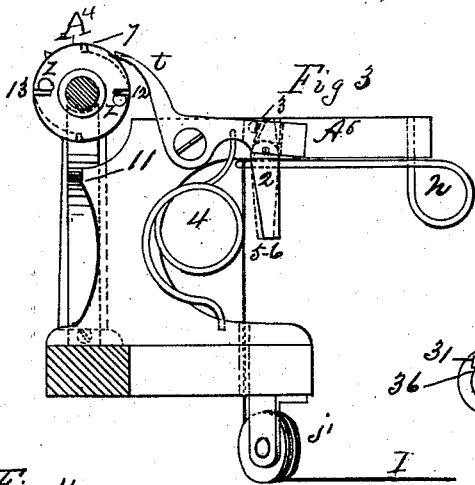
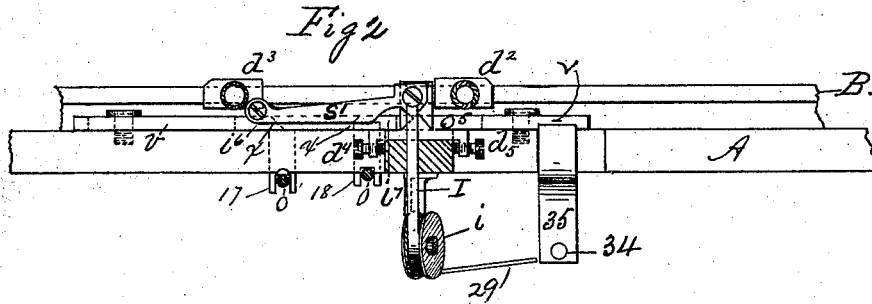

Witnesses
H. A. Chapin
Wm. A. Chapin

Inventors
James Russell
Austin Bemis
By Chapin & Co
Atty

J. RUSSELL & A. BEMIS.
Card-Setting Machine.

No. 211,186.

Patented Jan. 7, 1879.

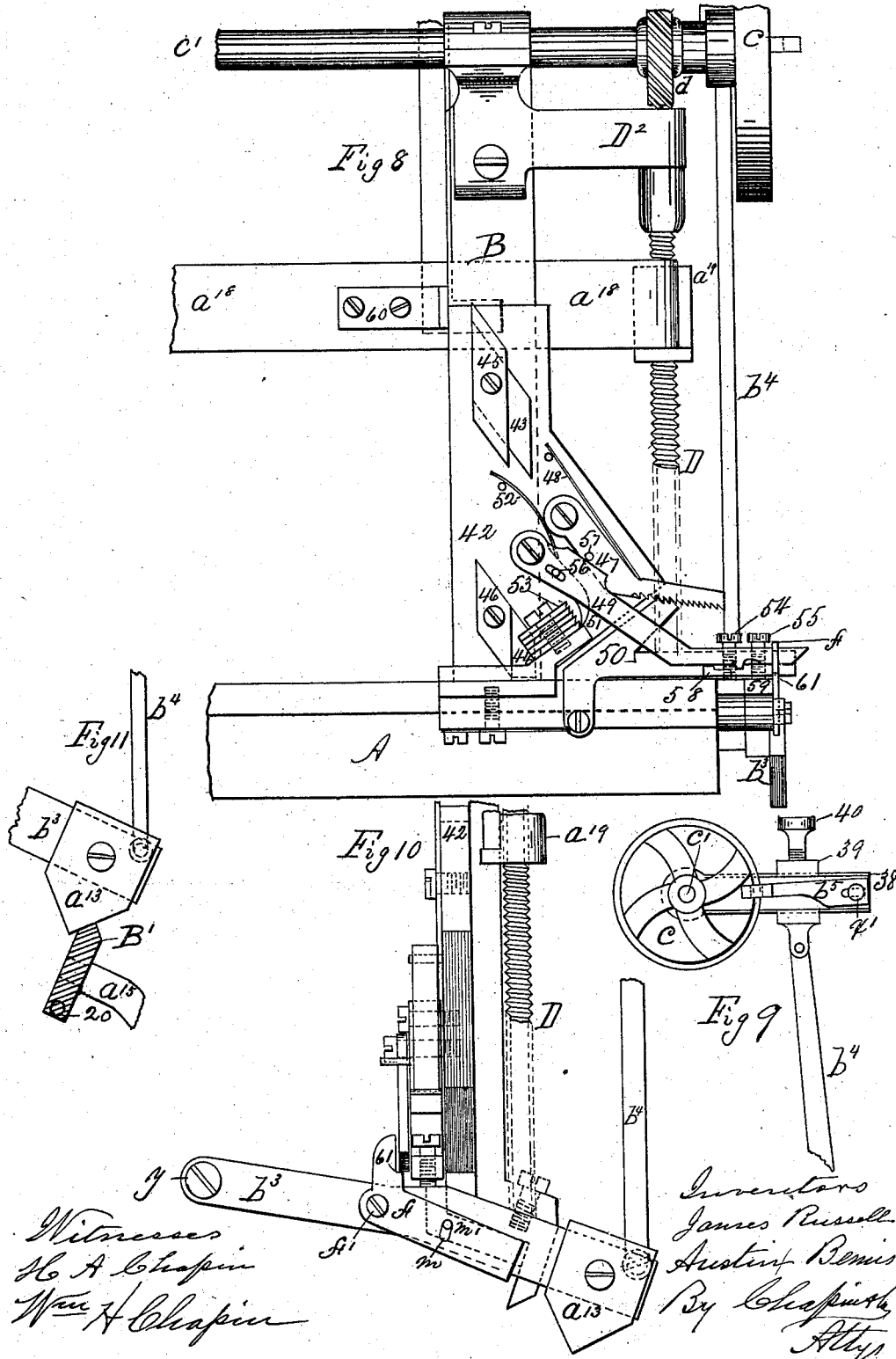

J. RUSSELL & A. BEMIS.

Card-Setting Machine.

No. 211,186.

Patented Jan. 7, 1879.

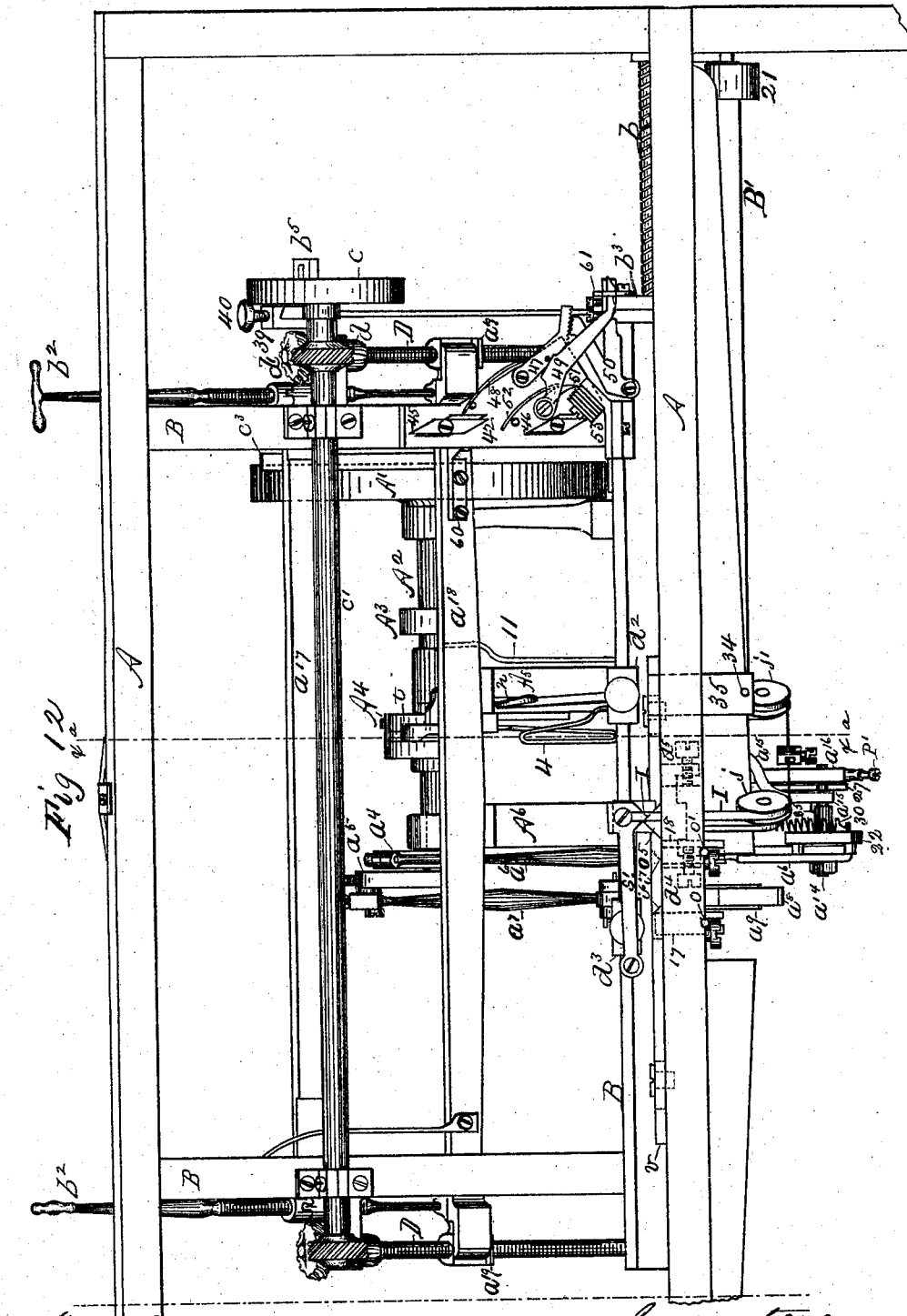

Witnesses
H. A. Chapin
H. A. Chapin

Inventors
James Russell
Austin Bemis
By Chapin & H. A.

J. RUSSELL & A. BEMIS.
Card-Setting Machine.

No. 211,186.

Patented Jan. 7, 1879.

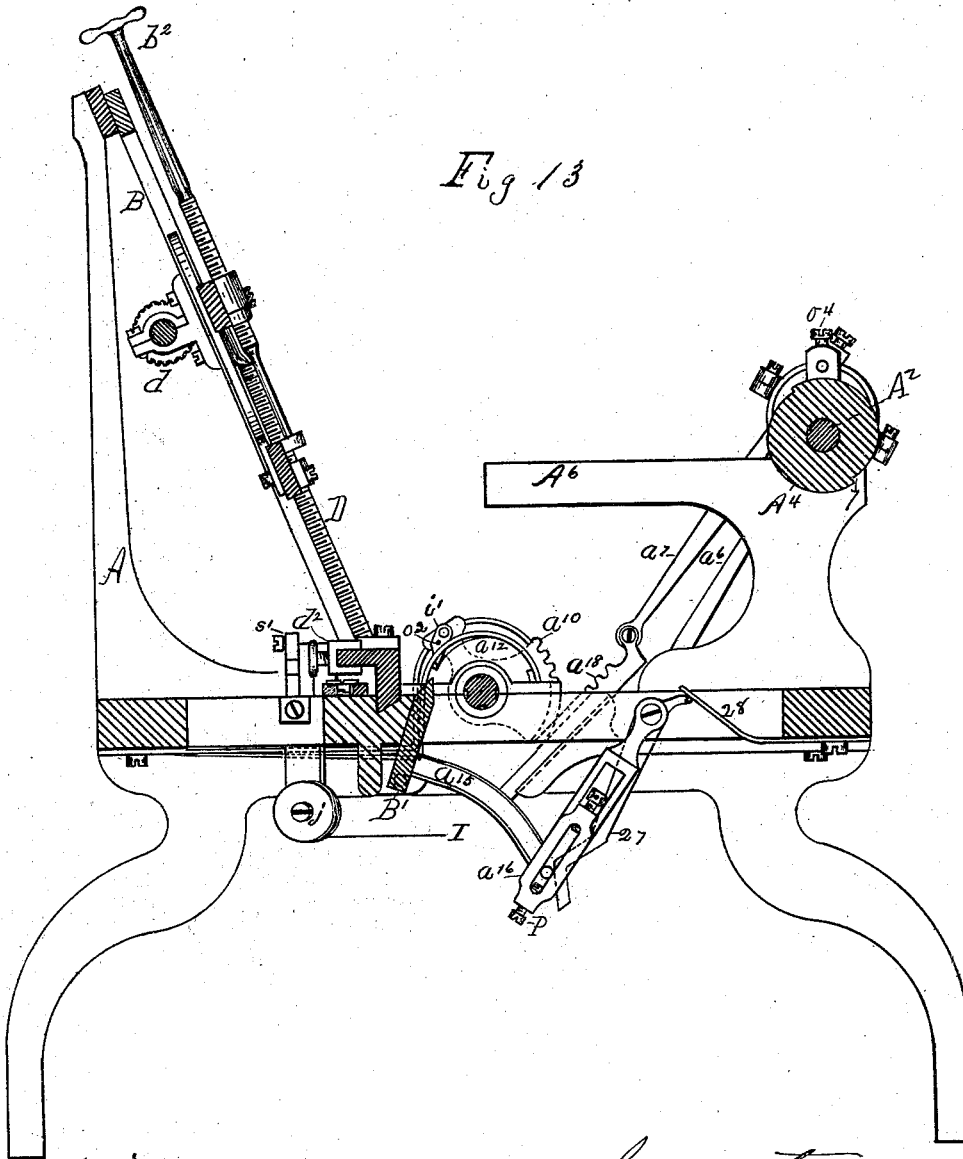

Fig 13

Witnesses
H. A. Chapin
Wm. A. Chapin

Inventors
James Russell
Austin Bemis
By Chapin & Co.
Attys.

UNITED STATES PATENT OFFICE.

JAMES RUSSELL, OF SPRINGFIELD, AND AUSTIN BEMIS, OF LEICESTER;
SAID BEMIS ASSIGNOR TO SAID RUSSELL; SAID RUSSELL ASSIGNOR
OF ONE-HALF HIS RIGHT TO HENRY A. COLLINS, OF SPRINGFIELD,
MASSACHUSETTS.

IMPROVEMENT IN CARD-SETTING MACHINES.

Specification forming part of Letters Patent No. 211,186, dated January 7, 1879; application filed
November 10, 1877.

To all whom it may concern:

Be it known that we, JAMES RUSSELL, of Springfield, county of Hampden, and State of Massachusetts, and AUSTIN BEMIS, of Leicester, county of Worcester, and State aforesaid, have invented new and useful Improvements in Machines for Setting Card-Teeth, which improvements are fully set forth in the annexed specification and in the accompanying drawings.

The drawings consist of six sheets and fourteen figures, in which—

Figure 1 is a plan view of our machine. Fig. 2 is a detached longitudinal view of a portion of the rear side of the machine, showing some of the working parts thereto attached.

In Fig. 1 a portion of the right-hand end of the frame and of the carriage is not represented, as upon the end of the latter would be shown, if drawn, parts that would be identical with those on the opposite end of the carriage, which parts are designated as follows, to wit, b^2 d d^1 D D^2 a^{19} .

Fig. 3 is a vertical section of a portion of the machine on the line $x x$, Fig. 1.

Fig. 4 is a detached view of the ratchets a^{11} and a^{12} , Fig. 1, with the geared sector a^{10} and rack a^8 removed, so as to show, with the screw-shaft b , on which they are placed with the fixed collar b^1 , the combination of these parts.

Fig. 5 is a longitudinal side elevation of the bottom end of pitman a^6 , which combines the principal devices by which the movements of the carriage B are made to impart the change motion to the twill-bar B^1 at the proper time.

Fig. 6 is a detached horizontal view of a portion of driving-shaft A^2 , Fig. 1, with the clutch A^4 .

Fig. 7 is a back elevation of the lower end of pitman a^6 , Figs. 1 and 5, with twill-bar change device, showing its connection by arbor a^{14} with twill-bar arm a^{15} , and a swinging support, a^{16} , to the latter.

Fig. 8 is an elevation of one end of the back side of the carriage B, with a portion of frame A of the machine, showing a part of the devices by which the up-feed and twill motion of the carriage are produced, and also shows the lower bar, a^{18} , to which the lower edge of

the leather is attached, raised high, so as to show its connection by nut a^{19} with vertical screw-shaft D.

Fig. 9 is an end elevation of lifting-rod b^4 , lever or arm 38, friction-pawl b^5 , and wheel c to the up-feed motion.

Fig. 10 is an end elevation of the lower portion of Fig. 8, showing the lifting-block a^{13} and lever b^3 , with rod b^4 , which are actuated by the twill-bar B^2 , Figs. 1 and 11.

Fig. 11 shows the relative positions of the twill-bar B^1 and lifting-block a^{13} .

Fig. 12 is a rear elevation of the machine without the legs, and with a portion of the frame left off beyond the dotted line at the left, to which no working parts are attached.

Fig. 13 is a cross-section elevation of the machine through line $x^3 x^3$, Fig. 12.

Fig. 14 is an end elevation of the machine, looking the opposite way from Fig. 13, in which portions of the end of the frame which would obstruct the view of its working parts are removed.

In the drawings like letters and figures refer to like parts in all the illustrations.

The object of our invention is to provide a machine for the above-named purpose, which, by reason of its peculiar and novel devices for producing and governing the requisite mechanical movements therein, can be run accurately at a much higher speed than ordinary machines, and which will require a much smaller outlay to keep it in running order than machines heretofore used for the said work have demanded; also to provide simple and effective devices for producing the feed-up motion, which, without the removal from and substitution of other parts on the machine, permit of instantaneous adjustments of such a degree of feed-up as may be required without being limited to such degree of up-feed of the leather bars as the width of a ratchet-wheel tooth may allow of; also to provide simple and effective devices which govern, by positive movements, the twill of the card; also, to provide such devices as permit of and will produce rapid intermittent movements of the carriage without giving any sudden shocks thereto during such movements;

also, to provide, by novel and effective devices, for the stop and start-up of the carriage at the end of the row of card-teeth while the last tooth of the row is being set and while the twill is being given.

In machines heretofore constructed the carriage is moved by a rack-and-pawl attachment, and said devices produce a movement of the carriage far from accurate, or not nearly as much so as such work demands that it should be. Also, to change the feed-up motion in such machines it is necessary to use one ratchet-wheel for each size wire, and hence when a new size must be worked it becomes necessary to remove a wheel from the machine and substitute another one therefor. Furthermore, in such machines the twill motions are governed by pins set in a wheel, which pins work against an inclined surface, and are likely, by wear or irregular motion of parts, to operate the twill devices inaccurately.

The above-mentioned and many other difficulties usually attending the successful operation of this unusually complicated class of machinery are overcome by the employment of our improvements.

The construction and operation of our machine are as follows, viz: The leather is secured to the carriage in the usual manner, and drawn firm between the bars a^{17} and a^{18} , Fig. 1, by turning screws b^2 .

The pricking and teeth-setting devices common to other machines are employed on ours, and are adjusted in the usual manner, and the wire-drawing lever on our machine has, in use, attached to it the usual devices employed therewith for drawing the wire from a reel, and so supply it to the machine, the said pricking and teeth-setting devices being located upon the portions of the frame A^5 and A^6 , Fig. 1, and upon the frame on the opposite side of the card, and are operated by proper connections with shaft A^2 . Previous to starting up the machine the bars a^{17} and a^{18} , holding the leather on the carriage, are lowered until the proper line near the upper edge upon which the first row of teeth should be set is brought before the pricking and teeth-setting devices. Said bars are so lowered by holding up the friction-pawl b^5 , Figs. 1 and 9, which leaves wheel c and its shaft c' , Figs. 1, 8, and 9, free to be turned back, thereby operating screw-shafts D , with which it is connected, and the nuts a^{19} thereon, by spiral gears d d^1 , the ends of the lower one of said bars, a^{18} , resting on a rear projection on nuts a^{19} , Fig. 8, which permit of a lateral motion to said bar while it may be carried up or down by said nut. Furthermore, said nut or nuts and bar are partially secured to each other by an arm on said nut, which reaches out onto the face of said bar through an elongated hole in which a screw passes into the bar. Said screw-shafts D , one at each end of the carriage, are attached to the carriage by supports D^2 , and their lower ends are stepped in countersunk spots on the base of carriage B , and are kept in a fixed vertical posi-

tion by collars placed on them directly under supports D^2 . The leather having been adjusted vertically, as heretofore described, the degree of the longitudinal movements of the carriage to and fro, governing the length of the rows of teeth, is determined by setting stop-blocks d^2 d^3 at such graduating-marks on the carriage-base as will indicate the required length of said rows of teeth.

The next required adjustment is to move the carriage on the frame so that the teeth-setting will be commenced at or near the end of the leather. This is done by turning screw-shaft b by a crank attached to one end of it; but it can be more quickly and conveniently done by disengaging nut E , which is secured to the under side of arm H on carriage B , from said shaft, when the carriage may be slid at will upon the frame. Said nut E is divided longitudinally, and each half of it is operated to be opened and shut from and against said screw-shaft by a cam attached to handle F ; and upon disengaging catch e^2 from a notch in the central circular portion of said handle and moving the handle in a direction from the carriage, the nut E is opened away from the screw-shaft, and a contrary subsequent movement of handle F brings the two halves of said nut again firmly into position against the screw-shaft, and catch e^2 so retains it in place.

The office of vertical support c^3 on carriage B , Fig. 1, is to prevent bar a^{17} from sliding longitudinally and from falling forward, and to make it move with bar a^{18} , to which it is attached.

Shaft A^2 is set in motion by a belt running upon pulley A^1 . Upon said shaft is a cam, A^3 , the face of which runs directly against the end of sliding bar h , and said operation of the cam, in combination with any suitable spring or weight operating to press the end of said bar against said cam, gives said sliding bar a reciprocating movement at right angles to said shaft A^2 . The said sliding bar is guided by a stud, e , coming up through a slot in it, and its forked-shaped end sliding each side of block e' . This sliding bar h has a slot, h^1 , cut across it obliquely, to receive the short bar h^2 , which is attached by and swings on a stud, i , to wire-drawing lever K . Thus the reciprocating movements of sliding bar h produce the required oscillating movements of the end of wire-drawing lever longitudinally with the frame of the machine.

We will suppose the machine to be running, and, through the connections of crank a^5 and pitman a^7 with rack a^8 , the latter is given an obliquely-reciprocating motion, sliding in its support and track a^9 . Upon screw-shaft b , turning freely thereon, is placed a geared sector, a^{10} , operated by said rack a^8 . Said sector is provided with an upwardly-projecting arm, on the sides of which are placed two pawls, i^1 i^2 , so hung that one of them is operative at each rotating reciprocating movement of said geared sector. Placed upon said screw-shaft, one on each side of said geared

sector, are two ratchets, a^{11} a^{12} , which are turned by the pawls on the sector a^{10} , the notches on said ratchets being so made as to be operated upon by pawls moving in opposite directions. The hubs to said ratchets interlock, as shown in Fig. 4, the sector a^{10} riding over such interlocking portion. The outside end of the hub of the right-hand ratchet, a^{11} , projects beyond the face thereof, and between the end of said hub and the adjoining box to the screw-shaft is interposed a spiral spring and collar, i^3 , for the purpose of producing sufficient frictional resistance against the hubs of said ratchets to prevent their turning during the backward movements of sector a^{10} and its pawls.

Interposed between the left-hand ratchet a^{12} and the adjoining box to screw-shaft b is a collar, b^1 , firmly fixed to said screw-shaft. In the edge of said collar, next to said ratchet, is set a pin, i^5 , projecting toward ratchet a^{12} , and on the edge of the hub of said ratchet is a segmental cut around one-fourth of its circumference, and said pin i^5 has a free oscillating movement from end to end of said cut.

Attached to the under side of the rear of the frame of the machine are two slim springs, o o^1 , which run forward, and, turning up back of and a little to one side of ratchets a^{11} a^{12} , have their ends bent to conform nearly to the circle described by the peripheries of said ratchets, and about one-half of their circumference.

Pins o^2 o^3 are placed one in the side of each of the pawls i^1 i^2 , near their dropping ends, and reach out over the circular portion of said springs o o^1 . While sector a^{10} is in operation, carrying, through screw-shaft b , the carriage B in one direction, one of said springs o o^1 is depressed to allow one of said pawls to operate and turn one of the ratchets; and when the motion of the carriage is reversed, the pawl last operating is, by one of said springs o o^1 , lifted up away from its ratchet, and the other spring is depressed, allowing the opposite pawl to operate on its proper ratchet, and so reverse the motion of screw-shaft b . The means by which said springs o o^1 are caused to operate as heretofore set forth will be described farther on.

The adjustment required to swing the sector and the pawls i^1 i^2 a proper distance beyond the ends of the ratchet-teeth, so as to avoid shocks in the forward movements and to take up for wear of parts, is provided for by means of a sliding crank-pin in crank a^5 , whereby said crank-pin may be fixed nearer to or farther from the center of said crank or of the crank-shaft. Said crank-pin consists of a screw passing through a box in halves in the end of pitman a^7 , and said screw passes through a slot in crank a^5 , and thence screwing into a nut on the side of said crank opposite to said pitman. A shoulder on said crank-pin is interposed between the pitman and crank. By turning back screw o^4 in crank a^5 , and by loosening the screw crank-pin, the lat-

ter may be slid toward the end of crank a^5 . Then, by partially tightening up on the screw crank-pin and turning down screw o^4 , the crank-pin may be adjusted to give the proper swing to pawls i^1 i^2 , and the screw crank-pin may then be firmly screwed home.

The carriage having been made to move on the frame the required length of a row of card-teeth will, upon so completing said movement, draw one of stop-blocks d^2 d^3 , Fig. 2, against a projection, r , Fig. 1, on slide v , Fig. 2, on the rear part of the frame A under the carriage B, and at each end of each row of teeth set said slide is caused to change its position by said movement of the carriage. The change of position of said slide by the operation of devices connected therewith, as will hereinafter be described, so acts as to stop the operation of one pawl and ratchet, and set the other one in operation, causes the clutch A^4 on shaft A^2 to be disconnected during one-half of a revolution of said shaft, and operates to elevate the card on the carriage and to change the twill. Said slide has attached to said projection r a fixed arm, s , Fig. 1. Hinged to the end of arm s is a swinging arm, s' , Fig. 1, terminating in a head opposite to projection r , the under side of said head being beveled to a point in the center, the faces of said bevels being at right angles to the length of said arm.

Under said beveled head is set in the frame of the machine a block, o^5 , corresponding in form to the beveled portion of said head. Said block o^5 is set in a slot in said frame, and is adjustable longitudinally by screws d^4 d^5 in each end of it, by which it may be so set as to produce the lift of arm s at precisely the right time, and by them is made fast to the frame.

Attached to the head of arm s' by a screw or otherwise is a metallic or other band, I, Figs. 2 and 3, which passes downward and over a pulley, j , and thence forward and over a second pulley, j' , and thence upward, and is attached to the end of spring n under the rear end of clutch-lever t , Figs. 3 and 14. When not drawn down by said metallic band, spring n bears up against a shoulder formed upon the side of swinging latch 2, which latch is hung by a stud on said clutch-lever, Fig. 3, and retains it in the position there shown, bearing against stud 3 in the portion A^5 of the frame, thus keeping the rear end of clutch-lever t down. As soon, however, as the end of spring n is drawn down, spring 4 operates to elevate the rear end of clutch-lever t , and latch 2 takes the position shown by the dotted lines 5 6. The upward action of arm s' , Fig. 2, is only instantaneous, and it immediately drops down again, with the point on the under side of the head on the other side of block o^5 , ready for the next clutch-change movement. Meanwhile, by the said action of arm s' and the parts combined therewith, as described, the forward end of clutch-lever t has been permitted to fall into a notch, 7, in the periphery of center-plate 8 to clutch A^4 . Said center-

plate 8 is formed as shown in Figs. 1, 3, 6, and has on its face next to clutch-points 9 and their hub 10, Figs. 1, 6, two grooves, cut in a line radiating from its center, into which said clutch-points interlock, said clutch-points extending from one side into notch 7, Fig. 3, at the bottom or deepest part thereof, Figs. 1, 3. The hub 10 of said clutch-point slides to and fro on shaft A^2 , being splined thereon, and is held up against center-plate 8 by spring 11, Fig. 3. The opposite side of center-plate 8 is provided with two projections, 12 13, Fig. 3, extending into perforations in flange 14; and on the bearing sides of said perforations, between them and said projections, are inserted rubber or other elastic cushions z , for the purpose of relieving the parts started up by the sudden movements of that part of the clutch from any injurious effects from the shock. Shaft A^2 passes completely through the clutch-point hub 10, flange and hub 15, center-plate 8, and flange and long hub 14, eccentric a^4 and crank a^7 being attached to the latter hub, to the right of box L, Fig. 1. Thus the clutch-points 9 being thrown out of connection with center-plate 8, it is obvious that the movements of eccentric a^4 and crank a^5 will cease. The clutch-points 9 are so thrown out of connection with center-plate 8 by the dropping of the forward point of clutch-lever t into and against the notch 7 in the center-plate 8. Clutch-points 9 do not reach quite across notch 7, and the portion of the end of clutch-lever which falls into said notch being made of an increasing width from its forward end back, it crowds the clutch-points back out of their locking-grooves by running between them (the points) and the inner face of flange 14, and fetches up against the bottom of notch 7 and stops that portion of the clutch to the right of the center-plate and the latter also. These parts rest motionless only during one-half of a revolution of shaft A^2 , for in the periphery of flange 15 are set two pins, 16, each of which is equidistant from said clutch-points, the latter passing quite through flange 15. The forward end of clutch-lever t is wider on the top than its under portion, which drops into notch 7, said wider portion projecting sidewise over that portion of flange 15 in which pins 16 are set, and is formed as shown in Fig. 1, so that when flange 15 in its revolution brings one of pins 16 under the end of said clutch-lever said pin lifts the end of said lever out of notch 7 in center-plate 8, in which upward position it is retained by spring n and latch 2, Fig. 3, and so the clutch-points 10 are permitted to spring and again put in motion with eccentric a^4 and crank a^7 into their grooves in center-plate 8, and their connections. Thus the drop of the end of the clutch-lever t into notch 7 produces the half of a revolution rest heretofore alluded to.

It has been heretofore remarked that the hub of ratchet a^{12} on screw-shaft b , Figs. 1, 4, has a segmental cut in it of one-fourth of its circumference. This is so made to permit the

ratchets to make one-fourth of a turn when taking up a reverse motion without moving the screw-shaft b and carriage B, and said one-fourth of a revolution rest with the one-fourth of a revolution rest of eccentric and crank, produced by the disconnection of the clutch A^4 , already described, produce together the required rest of the card at the end of the row of teeth while the last tooth of the row is being set and while the twill is being changed.

Having described the devices by which the carriage is, at the end of each row of teeth, caused to rest the requisite time, for the purposes above stated, we will now describe the devices, and their operation, by which the pawls i^1 i^2 are caused to operate successively, first upon one and then upon the other of ratchets, a^{12} and a^{11} , so as to reverse the motion of screw-shaft b , and by which the feed-up of the card and the twill are produced.

As before stated, slide v , Fig. 2, is caused to move by the carriage at the end of each row of teeth set. By reference to Fig. 2 it will be seen that there are two rectangular openings, i^6 i^7 , through said slide, and that the ends of said openings next to the center of said slide are beveled off, as shown by two dotted lines, x x , Fig. 2. Under said slide in the frame are drilled two holes, in which are inserted two loosely-fitting pins 17 18, their top ends of a convex form and their bottom ends fork-shaped. The lower ends of said pins stand astride of springs o o^1 , Figs. 1, 2, the rear ends of which are firmly fastened to the under side of the frame at 19, Fig. 1, a certain distance from their point of contact with said pins, these being the same springs heretofore referred to as running forward and terminating in a half-circle bend by the side of ratchets a^{11} a^{12} , Figs. 1, 13, and 14. Thus it is obvious that when slide v is moved by the carriage so that one of openings i^6 i^7 is brought over the end of one of pins 17 18, the pin heretofore held down by said slide, and bearing down with it one of said springs o o^1 , will rise up, letting the spring upon which it bears rise up also. This movement of the spring lifts up the pawl i^1 or i^2 , as heretofore described, and allows it to swing with the movements of the sector without permitting it to engage in the teeth of its ratchet. At the same time that the pin just mentioned rises up, the second pin is, by the same movement of the slide, pressed down by the beveled edge of the adjoining opening as it slides against it, bringing the top end of the pin to press squarely against the under side of slide v . This depresses the second spring and allows the pawl which it held up to drop upon its ratchet and engage in the teeth thereof. Thus by the alternate lifting and dropping of said pawls by said springs the reversing intermittent rotary motions of screw-shaft b are produced.

The feed-up and twill motions are produced by the oscillating movements of what we call a "twill-bar," B' , Figs. 1, 11, and 13. Said twill-bar is pivoted at each end to the frame,

said pivots being placed as shown at 20, Fig. 11. Projecting from one side, near the left-hand end, is an arm, 21, serving as a counter balance or weight to other parts on the opposite side of said bar. On the right-hand end is a bent arm, a^{15} , Figs. 7, 11, and 14, and inserted through the end of it, at right angles to it, is an arbor, a^{14} , Figs. 5, 7. On said arbor is placed a swinging bar, 22, with a hollow hub, 23, in which is a notch, 24, slipping over a stop-pin, 25, set in said arbor. Said notch 24 is wide enough to allow said swinging bar to oscillate to a limited extent on said arbor a^{14} . One end of said arbor passes loosely through a slot, 26, in the end of pitman a^6 , Figs. 5, 7, and 14, and is there secured by a nut on its end. The opposite end of said arbor projects beyond the face of said arm a^{15} , and enters a slot in a catch-support, a^{16} , Fig. 7. At each end of the said slot in said catch-support is an adjusting set-screw, P P', by which the degree of up-and-down movement of the arbor a^{14} can be regulated. Hung on the side of said support a^{16} is a catch, 27, arranged so that its edge next to arbor a^{14} presses against the latter by the action of a spring, 28, Figs. 1 and 13, bearing on a bent arm at its upper end. From a point on the edge of said catch 27 the edge is filed away, making a sharp incline toward each end of said catch, so that the end of arbor a^{14} in moving up or down in the slot in support a^{16} presses said catch back as it passes over the high point on it, and the incline from the point of rest of said arbor a^{14} up to the high point on the catch serves to prevent any movement of bent arm a^{15} unless it be actuated by its proper connections.

Swinging bar 22, Figs. 5, 7, is arranged to be operated and thrown into and out of connection with the slotted end of pitman a^6 , Fig. 5, by the cord 29 and retracting-spring 30. Said cord is caused, by its attachment to slide v , to draw over the end of the swinging bar to which it is attached far enough to bring a projection, 31, on its face down about to the center of the slot in the pitman a^6 , when the pitman in its next upward movement will catch against projection 31, and carry said swinging bar, its arbor a^{14} , and bent arm a^{15} to twill-bar B' up with it, where it will be held by catch 27 until slide v is pushed back to a reverse position, when, cord 29 being released, retracting-spring 30 causes swinging bar 22 to regain its previous position, in which a second projection, 32, on the face of said swinging bar is brought into position to be struck by the upper end of the slot in pitman a^6 in its next downward movement, and so carry bent arm a^{15} down again, thus turning twill-bar B' back to its previous position. Cord 29 passes over pulley 33, Fig. 5, and thence the end is secured to the stud 34, attached to arm 35 on slide v , Fig. 2. The upper end of pitman a^6 is connected to shaft A² by eccentric a^4 , Figs. 1, 13, and 14; and the portion of its face next to swinging bar 22 above the lines 36-37 is cut away to allow of a free upward

movement of the pitman a^6 when swinging bar 22 stands in the position shown in Fig. 5, without drawing the swinging bar and its connections up with it. Thus, through the movements of slide v , actuated by the carriage, and its connections with the devices hereinbefore described, the twill-bar is made to swing in one direction on the completion of a row of teeth in the leather, and in an opposite direction on the completion of the next row, and so on.

A vertical section of twill-bar B' is shown in Figs. 11 and 13, with a portion of its bent arm a^{15} , in which may be seen the shape of its top edge, beveled from its sides to a high point in the center. The same figure also shows lifting-block a^{13} in its relative position to twill-bar B', by which it may be seen that the oscillatory movements of said twill-bar produce a lifting-and-falling motion in said block and in the end of lever b^3 , to which it is attached, and through the same to rod b^4 , Figs. 8, 9, 10, 11.

On shaft c^1 , Figs. 1, 8, 9, is placed, inside of wheel c , arm 38, which swings freely up and down. On said arm is fitted slide 39, which may be moved to any required position on said arm, and be there secured by set-screw 40, Fig. 9. To the lower end of slide 39 is hinged rod b^4 , the lower end of which is suitably connected to lever b^3 on or near block a^{13} .

Attached also to arm 38, Figs. 1, 9, is a friction-pawl, b^5 , swinging freely on screw x , the hole for which in said arm is slightly elongated. The opposite end of said friction-pawl is of a hook shape, arranged to bear, when said end is down, against the outer surface of said wheel c , and against a portion of the inside of the rim, and so get a biting hold on it. Thus each time the lifting-block a^{13} is raised by the action of the twill-bar, wheel c is revolved to a degree determined by the position of slide 39 on arm 38; and with the revolving of said wheel, its shaft c^1 , and spiral gears d on the same, and spiral gears d^1 , with which the former ones interlock, on the upper ends of screw-shafts D, the latter operate to raise the leather secured to bars a^{17} , a^{18} as hereinbefore mentioned.

It will be seen that when arm 38 falls, the end of pawl b^5 which hooks around the edge of wheel c freely slides around the rim of same, and is made to turn the wheel by having its end which is secured to arm 38 lifted up until the hooked part of it bites and lifts up on the rim of the wheel.

On the arm attached to the end of the carriage, Fig. 10, and running back, is a lifting-and-falling lever, b^3 , hung on screw y . On the opposite end is fixed lifting-block a^{13} . On the side of lever b^3 is an elbow-shaped latch, f , swinging on screw f' , and having a slot, m , through it. A pin, m' , is inserted through said slot into the before-mentioned arm.

On the back side of the carriage, as shown in Fig. 8, are attached a series of twill-setting

devices, which are operated by lever b^3 , Fig. 10; and they consist of a base-plate, 42, in which are cut two openings, 43 44, of the form of a parallelogram, whose top and bottom lines run obliquely to the vertical lines of said base-plate. Said base-plate is movable obliquely on the carriage, sliding on blocks 45 46, fitted to said openings, but enough narrower than they are to allow of the requisite oblique movement of base-plate thereon. Said blocks 45 46, are screwed to the carriage, and a flange on the ends of one of said blocks secures said base-plate against the carriage. Hung on the face of said base-plate 42 is a crooked lever, 47, the face of the under side of which is serrated. Said lever 47 is pressed down by a spring, 48, attached to said base-plate. Hung also on the face of base-plate 42 is a second crooked lever, 49, reaching by the side of lever 50 out over the top of lever b^3 ; and upon the same pivot upon which swings lever 49, but between it and the base-plate 42, is hung a pawl, 51, pressed down by a spring, 52; and attached to the carriage is a serrated-faced block, 53, upon which the point of pawl 51 operates. Hung on the carriage is a two-pronged lever, 50, the upper prong of which reaches up to and directly under the end of lever 47, and, like the latter, has also a serrated face, the two serrated faces operating together for a purpose hereinafter described.

The lower prong of lever 50 reaches out over lever b^3 , Figs. 8, 10, and has in it two adjusting set-screws, 54, 55, by which it can be adjusted at a proper commencing-point of motion. The latter lever is held down against lever b^3 by any conveniently-arranged spring. A stud, 56, is set in pawl 51, and plays in a slot in lever 49; and a stud, 57, set in lever 47 reaches out over the top edge of lever 49. On arm next to lever b^3 , under lever 49, is set a block, 58, upon which rests the latter lever, and upon the under side of said lever 49 is a downwardly-projecting spot, 59.

Upon bar a^{18} of the carriage is a block, 60, arranged to be kept to a bearing laterally against the vertical portion of the carriage, and joining it, and against the edge of base-plate 42, by a spring attached to said bar and pressing against the vertical portion of the carriage on the end opposite to where the twill-setting devices are placed. Said twill-setting devices operate as follows, viz: Lever b^3 being raised by the operation of the twill-bar upon block a^{13} , it carries up the end of lever 50, which, in turn, by the bearing of its serrated face against the serrated face of lever 47, forces up obliquely the base-plate 42 and its connections, and the latter is retained at such elevation by the pawl 51, whose point drops into one of the notches on block 53. Said upward and oblique movement of base-plate 42 crowds the latter against block 60 on bar a^{18} , and so moves the latter, with the card-leather attached to it, laterally by the points of the pricking and teeth-sticking devices, thus set-

ting it off at the end of each row of teeth to produce the twill.

The before-described movements are repeated the required number of times to produce the necessary offset or lateral movements of the card, when base-plate 42 will be lifted to its highest point, still retained there by pawl 51, as heretofore described. While base-plate 42 has been moving off obliquely, it has drawn lever 49 over block 58 until spot 59 on said lever rests upon said block, thus lifting up its end higher than it was at the commencement of said oblique movements. When lever 49 so rests high on block 58 the long end of latch f on the side of lever b^3 falls down and brings catch 61 on said latch under lever 49, and the next upward movement of lever b^3 lifts up lever 49, and the latter, pressing against stud 57 in serrated lever 49 and stud 56 in pawl 51, lifts up the two latter, so that they trip them and let fall obliquely base-plate 42 and its connections, and consequently allowing bars a^{17} a^{18} and the card thereon to return laterally to their starting-point on the carriage.

Before the latch f acts to trip the parts, as heretofore described, the portion of said latch below the notch 61 is bearing lightly against the side of lever 49, actuated by the weight of its longer arm, and the notch falls under the lever when the latter is raised sufficiently high. The purpose of the stud m' through the slot in latch f is, so that the weight of the latter may hang upon said stud during the last upward movement of lever b^3 , and at the moment the parts are tripped and made to slide down, and so prevent any frictional resistance between catch f and the side of lever 49.

The clutch hereinbefore described and its immediate operating devices are not the invention of this application, being reserved for a separate protection.

What we claim as our invention is—

1. In a machine for setting card-teeth, the combination of driving-shaft A^2 , cam A^3 , sliding bar h , with its oblique slot h^1 , stud e , block e^1 , wire-drawing lever K and its stud i , and obliquely-sliding bar h^2 , substantially as and for the purpose set forth.

2. The combination of the eccentric a^4 , pitman a^6 , with its slotted lower end and its uneven face above lines 36 37, and flange and long hub 14 to clutch A^4 , substantially as and for the purpose set forth.

3. The combination, with pitman a^6 , of arbor a^{14} , with its stop-pin 25, swinging bar 22, with its hollow hub 23 and its projections 31 and 32, cord 29, retracting-spring 30, and slide v , substantially as and for the purpose set forth.

4. The combination, with arbor a^{14} , of twill-bar-arm support a^{19} , with its adjusting-screws P P' , catch 27, and spring 28, substantially as and for the purpose set forth.

5. Twill-bar B' and its bent arm a^{15} , in combination with arbor a^{14} , support a^{16} , swinging bar 22, and pitman a^6 , substantially as set forth.

6. In combination, slide v , with its fixed arm

- s and lifting-arm s' , pointed block o^5 on frame A, metallic band 1, spring n , latch 2, stud 3, clutch-lever t , spring 4, and clutch A^4 , substantially as and for the purpose set forth.
7. Pointed block o^5 , secured to and adjustable on frame A by set-screws d^4 d^5 , substantially as set forth.
8. In a machine for setting card-teeth, the twill-bar B', having intermittent oscillatory movements, said movements being communicated to it through suitable connections with the intermittently-moving pitman a^6 , substantially as and for the purpose set forth.
9. In a machine for the above-specified purpose, the twill-bar B', combined with pitman a^6 , slide v , cord 29, swinging bar 22, spring 30, and carriage B, whereby said slide v , by the movements of said carriage against it, causes the oscillation of the twill-bar on the arrival of said carriage at predetermined points in its longitudinal movements on frame A, substantially as set forth.
10. The combination of carriage B, stop-blocks d^2 d^3 , projection r , and slide v , substantially as and for the purpose set forth.
11. The combination of stop-blocks d^2 d^3 with graduating-marks on the base of carriage B, substantially as and for the purpose set forth.
12. The combination of carriage B, stop-blocks d^2 d^3 , slide v , projection r , fixed arm s , lifting-arm s' , and block o^5 , substantially as and for the purpose set forth.
13. The combination of slide v , its arm 35, stud 34, cord 29, swinging bar 22, and retracting-spring 30, substantially as and for the purpose set forth.
14. The combination, with a suitable operating-clutch on shaft A^2 , of crank a^5 , pitman a^7 , rack a^8 , rack-support a^9 , geared sector a^{10} , pawls i^1 i^2 , ratchets a^{11} a^{12} , and screw-shaft b , substantially as and for the purpose set forth.
15. The combination of the intermittently-rotating screw-shaft b , the longitudinally-divided nut E, and carriage B, substantially as and for the purpose set forth.
16. The combination, with the screw-shaft b , of the longitudinally-divided nut E, cam-handle F, and catch e^2 , substantially as and for the purpose set forth.
17. The combination of sector a^{10} , ratchets a^{11} a^{12} , pawls i^1 i^2 , and springs o and o^1 , substantially as and for the purpose set forth.
18. The combination of springs o o^1 , pins 17 18, and slide v , substantially as and for the purpose set forth.
19. The combination of carriage B, slide v , pins 17 18, and springs o o^1 , substantially as and for the purpose set forth.
20. The combination of crank a^5 , pitman a^7 , rack a^8 , sector a^{10} , pawls i^1 i^2 , ratchets a^{11} a^{12} , springs o o^1 , pins 17 18, slide v , and carriage B, substantially as and for the purpose set forth.
21. The combination of ratchets a^{11} a^{12} , collar b^1 and its pin i^5 , screw-shaft b , sector a^{10} , rack a^8 , pawls i^1 i^2 , pitman a^7 , and crank a^5 , substantially as and for the purpose set forth.
22. Ratchet a^{12} , with its segmental cut on its hub, in combination with collar b^1 , with its pin i^5 , substantially as and for the purpose set forth.
23. The combination of spring-collar i^3 , ratchets a^{11} a^{12} , collar b^1 and its pin i^5 , and screw-shaft b , substantially as and for the purpose set forth.
24. In a machine for setting card-teeth, the combination, with a screw-shaft and nut for moving the carriage, of reversely-operating ratchets, which ratchets are caused to rotate by a geared sector having a reciprocating rotary motion, and carrying on it suitable pawls for rotating said ratchets in opposite directions, substantially as set forth.
25. The combination of clutch-lever t , clutch A^4 , hollow-shaft 14, crank a^5 , pitman a^7 , rack a^8 , geared sector a^{10} , pawls i^1 i^2 , ratchets a^{11} a^{12} , collar b^1 , with its pin i^5 , whereby screw-shaft b is caused to cease its movements temporarily, substantially as set forth.
26. In a machine for setting card-teeth, the combination, with the carriage B, of reversely-operating ratchets a^{11} a^{12} , the intermittently rotating screw-shaft b , and a nut, E, the reverse movements of said ratchets being caused by the arrival of said carriage at predetermined points in its longitudinal movements on frame A, substantially as set forth.
27. The combination of twill-bar B', lifting-block a^{13} , lever b^3 , rod b^4 , slide 39, arm 38, friction-pawl b^5 , and wheel c , substantially as and for the purpose set forth.
28. The combination, with wheel c , of shaft c^1 , spiral gears d d^1 , screw-shafts D, nuts a^{19} , and bar a^{18} , substantially as and for the purpose set forth.
29. The combination of carriage B, screw-shafts D, shaft c^1 , wheel c , spiral gears d d^1 , arm 38, slide 39, friction-pawl b^5 , rod b^4 , and lifting-block a^{13} , substantially as and for the purpose set forth.
30. The combination of lever b^3 , two-pronged lever 50, lever 47, spring 48, pawl 51, serrated-faced block 53, and base-plate 42, substantially as and for the purpose set forth.
31. The combination, with base-plate 42, arranged to move obliquely on carriage B, of block 60, bar a^{18} , vertical support e^3 , and bar a^{17} , substantially as set forth.
32. The combination of lever b^3 , latch f , with its notch 61, crooked lever 49, block 58, pawl 51, and stud 57 on lever 47, substantially as and for the purpose set forth.
33. The combination of base-plate 42, lever 47, spring 48, lever 50, lever 49, pawl 51, spring 52, serrated-faced block 53, blocks 45 46, carriage B, lever b^3 , lifting-block a^{13} , and twill-bar B', substantially as and for the purpose set forth.
34. In combination, twill-bar B', lifting-block a^{13} , lever b^3 , rod b^4 , slide 39, arm 38, pawl b^5 , wheel c , shaft c^1 , spiral gears d d^1 , screw-shafts D, nuts a^{19} , bars a^{17} a^{18} , latch f , lever 49, lever 50, lever 47, spring 48, pawl 51, spring 52, serrated-faced block 53, block 58, base-

plate 42, blocks 45 46, carriage B, and block 60 on bar a^{13} , whereby by an upward movement of lever b^3 , actuated by the oscillating movements of twill-bar B', the feed-up of the card and the set of the twill are simultaneously effected.

35. The combination of lifting-block a^{13} , rod b^4 , slide 39, arm 38, friction-pawl b^5 , wheel c ,

and shaft e^1 , substantially as and for the purpose set forth.

JAMES RUSSELL.
AUSTIN BEMIS.

Witnesses:

WM. H. CHAPIN,
H. A. CHAPIN.