

G. R. SEQUERA & J. de C. DOMINGUER.  
 Steam-Generators.

No. 211,190.

Patented Jan. 7, 1879.

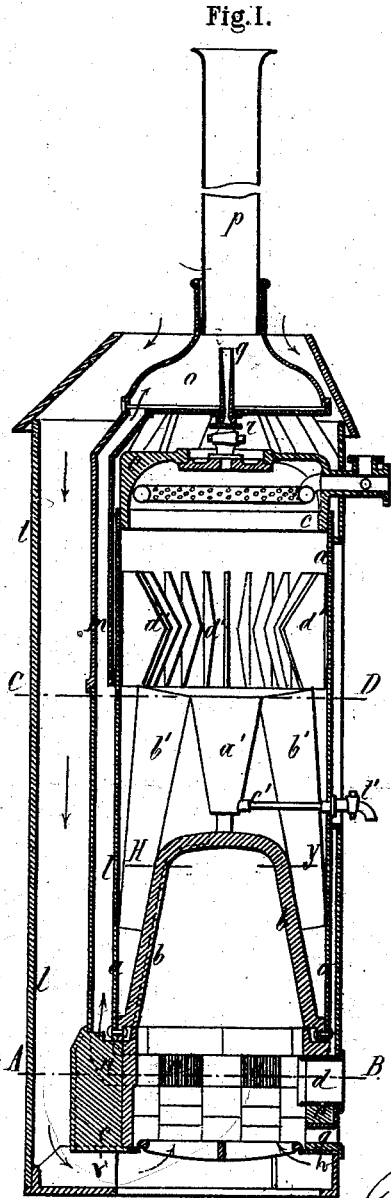

Fig. 1.

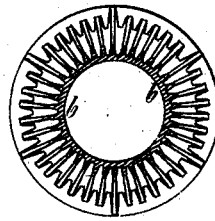

Fig. 2.

Fig. 5.



Fig. 3.

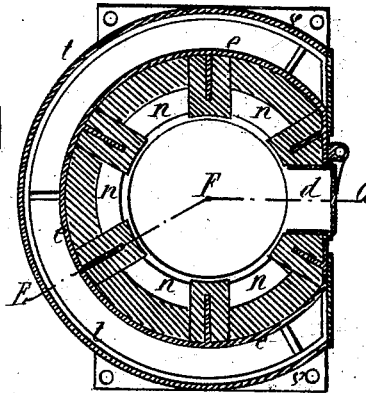

Fig. 4.

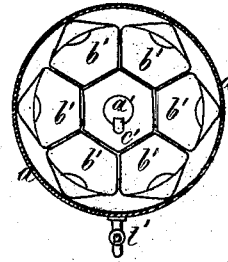

Fig. 7.

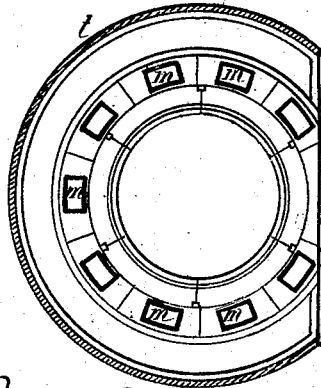
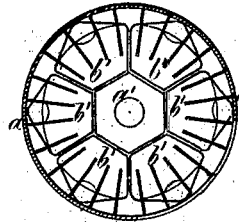

Fig. 6.



Witnesses,  
*J. H. Murray*  
*H. A. ...*

*Guillermo Reinlein y Sequera &*  
*José de Canterac y Dominguer*  
*Inventors*  
*By Atty. John O. ...*

# UNITED STATES PATENT OFFICE.

GUILLERMO REINLEIN Y SEQUERA AND JOSÉ DE CANTERAC Y DOMINGUER,  
OF MADRID, SPAIN.

## IMPROVEMENT IN STEAM-GENERATORS.

Specification forming part of Letters Patent No. **211,190**, dated January 7, 1879; application filed July 1, 1878; patented in France, April 2, 1878.

*To all whom it may concern:*

Be it known that we, GUILLERMO REINLEIN Y SEQUERA and JOSÉ DE CANTERAC Y DOMINGUER, of Madrid, Spain, have invented an Improved Steam-Generator, of which the following is a specification:

The object of our improved steam-generator is to effect a considerable economy in fuel, and at the same time to avoid the three chief defects common to nearly all steam-generators, viz: first, ready burning of the metal walls or sides as soon as the combustion of the furnace is at all forced; second, drawing of water with the steam which issues from the boiler; and, third, difficult removal of the sediment and incrustation which are produced as the water evaporates.

The invention will be readily understood by the aid of the annexed drawing, Figure 1 of which is a vertical section of our improved steam-generator, with furnace, smoke or fire tubes, air-tubes, and chimney; and Fig. 2, a horizontal section of the cone *b* through the line H Y.

The generator is of vertical form and cylindrical. Its lower part consists of a cone, *b*, of cast-iron or steel, terminated at the lower part by a flange, to which is riveted the sheet-iron cylinder *a*, which forms the principal casing or body of the generator. Vertical ribs (the shape and form of which are seen in Figs. 1 and 2) are arranged externally on the cone *b* for the whole height of the same.

The upper part of the boiler is formed of a cast-iron cover, *c*, riveted to the top of the sheet-iron cylinder *a*. In the said cover there is, in addition to a man-hole, situated in the center, a lateral tube, in which are holes for the outlet of the steam and the safety-valve.

The "boiler," properly so called, is placed upon a furnace, which is in the form of a cast-iron cylinder, having six (more or less) vertical ribs, upon which the boiler rests. The interior of the said furnace is provided with fire-bricks, in order that all its sides or walls may be preserved from the heat of the fire-place, which occupies the center, Fig. 1, and particularly Fig. 3, which is a horizontal section of the furnace through the line A B, clearly showing the arrangement. The fuel is sup-

plied by the door *d* of the furnace, and the grate can be cleared by the small opening *g*, Fig. 1, situated below the door *d*. The ashes fall into an ash-pit completely closed, which should be constructed under the grate, and should be provided with a door, to enable the ashes and other residues to be extracted from time to time.

A cylindrical casing, *l*, rests upon the ribs of the furnace *e*, and serves as a channel for the flame and smoke. The height of this casing is that of the level of the water in the boiler. The products of combustion are conveyed to this casing by the passages *n*, formed of fire-brick, and from there to the chimney *p* through the cast-iron tubes *m* and the smoke-box *o*.

In order to increase the draft of the chimney a jet of steam is discharged therein at pleasure by means of the cock *r*, and issues by the tube *q*. The special form of the interior of this tube is clearly seen in Fig. 5. The upper portion is in the form of an inverted cone, *s*, and has the effect of giving a greater expansion to the steam before mixing with the gaseous products which enter the chimney. By this means the steam attains a great speed and increase of volume, and its work is utilized to the utmost. At the same time the amount of steam used is comparatively small.

The furnace *e* rests upon three vertical ribs of the foundation-plate *v*. A cylindrical wooden casing, *t*, surrounds the furnace *e* and the smoke-channel *l*. This casing extends from the foundation-plate *v* nearly to the base of the chimney. It is between this casing and the furnace that the air entering at the top and descending in the direction of the arrows passes underneath the furnace *e*, and supports the combustion in the fire-place. As this air in its descent comes in contact with the furnace *e*, the cast-iron casing *l*, the tubes *m*, and the smoke-box *o*, it is considerably heated when it reaches the fire-place, and thus causes a more active combustion. The external wooden casing *t* is lined with a layer of felt, which insures the complete utilization of the heat.

In the interior of the boiler, above the cone *b*, which forms the bottom, is a pipe, *a'*, in the

form of a truncated cone, for receiving the sediments produced by the evaporation of the water, and around this central pipe, *a'*, are arranged six pipes, *b'*, of the same form, which cause a continuous circulation of the water in the boiler. Two advantages of great importance are thus gained—viz., the immediate separation of the steam from the metallic sides of the boiler without adhering thereto, and the deposit of the sediments, which are the cause of incrustation in the pipe *a'*, from which they are removed by the pipe *c'*, leading to the outside of the boiler.

In order to assist the steam as it reaches the surface of the liquid in freeing itself from sedimentary matters and from the water which it draws with it on account of its electric condition, we place above the pipes *b'* a series of vertical plates, *d'*, arranged on radial lines. On coming into contact with these plates the steam, losing its electricity before reaching the surface of the liquid, frees itself from the sedimentary matters and water, so that the water falls to the bottom of the boiler through the pipes *b'* and causes a continuous movement, while the sediment becomes deposited in the pipe *a'*, owing to the centrifugal force produced by the movement of water.

Fig. 4 is a horizontal section of the boiler through the line *CD* of Fig. 1. Fig. 6 is a horizontal section of the sheet-iron cylinder *a*, in which is seen the position of the small plates *d'*, pipes *b'*, and pipes *a'*. Fig. 7 is a horizontal section of Fig. 1, leaving out the boiler *a*, smoke-box *o*, and chimney *p*.

We claim—

1. In a steam-generator, the combination of the cone *b*, constructed with vertical ribs upon its outer surface, the fire-box below cone *b*, passages *n* from the fire-box, leading to flues opening into the chimney, and the outer cylindrical casing, *t*, open above the boiler, and leading downward below the grate, and opening thereto, for the supply of air for combustion, all substantially as described.

2. In a steam-generator, the combination of the cone *b*, constructed with vertical ribs upon its outer surface, the fire-box below cone *b*, passages *n* from the fire-box, leading to flues opening into the chimney, the inverted conical pipes *a'*, provided with a draw-off cock, and the pipes *b'*, surrounding said pipes *a'*, all as described.

3. In a steam-generator, the combination of the cone *b*, constructed with vertical ribs upon its outer surface, the fire-box below cone *b*, passages *n* from the fire-box, leading to flues opening into the chimney, the inverted conical pipes *a'*, provided with a draw-off cock, the pipes *b'*, surrounding said pipes *a'*, and the vertical radial plates *d'*, above said pipes *a'*, all substantially as specified.

In testimony whereof we have signed our names to this specification before two subscribing witnesses.

GUILLERMO REINLEIN Y SEQUERA.  
 JOSÉ DE CANTERAC Y DOMINGUER.

Witnesses:

JOSÉ LARRUMBE,  
 RICARDO ORTEGA Y DIEZ.