

S. G. READ & H. D. KAHLER.
Fire-Extinguisher for Car-Stoves

No. 211,261.

Patented Jan. 7, 1879.

Fig. 1.

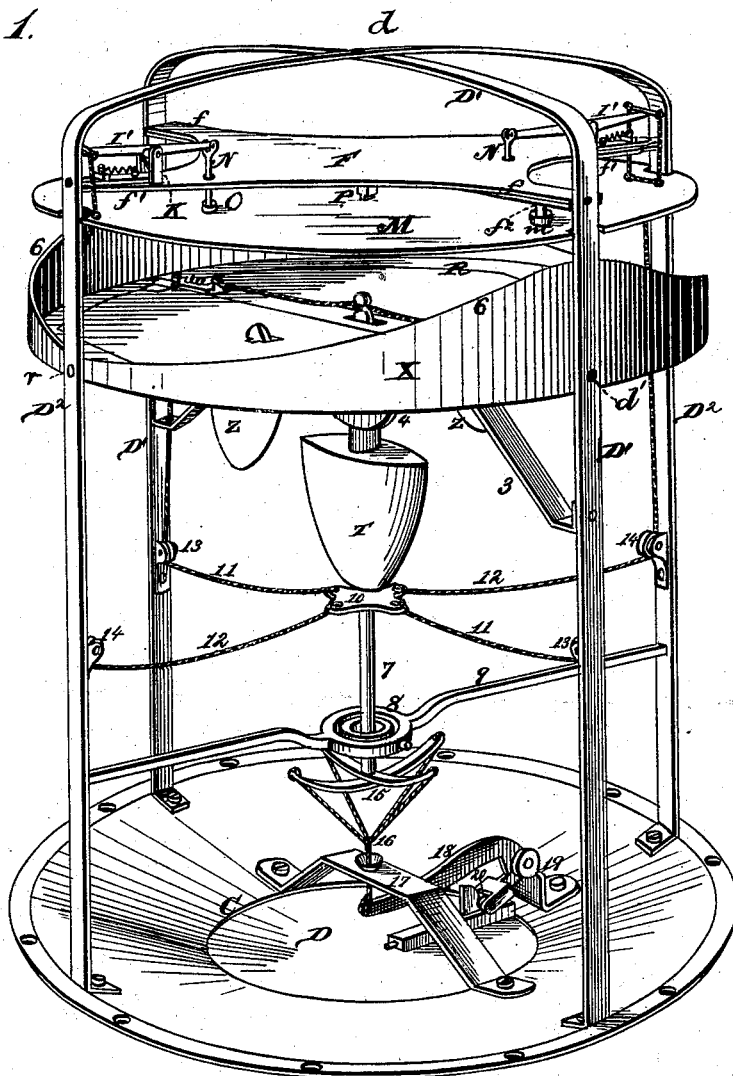

WITNESSES
Robert Smith
W. Clay Smith

INVENTORS.
Stephen Griswold Read,
Henry D. Kahler.
By *J. Moore Smith & Co.* ATTORNEYS.

S. G. READ & H. D. KAHLER:
Fire-Extinguisher for Car-Stoves.

No. 211,261.

Patented Jan. 7, 1879.

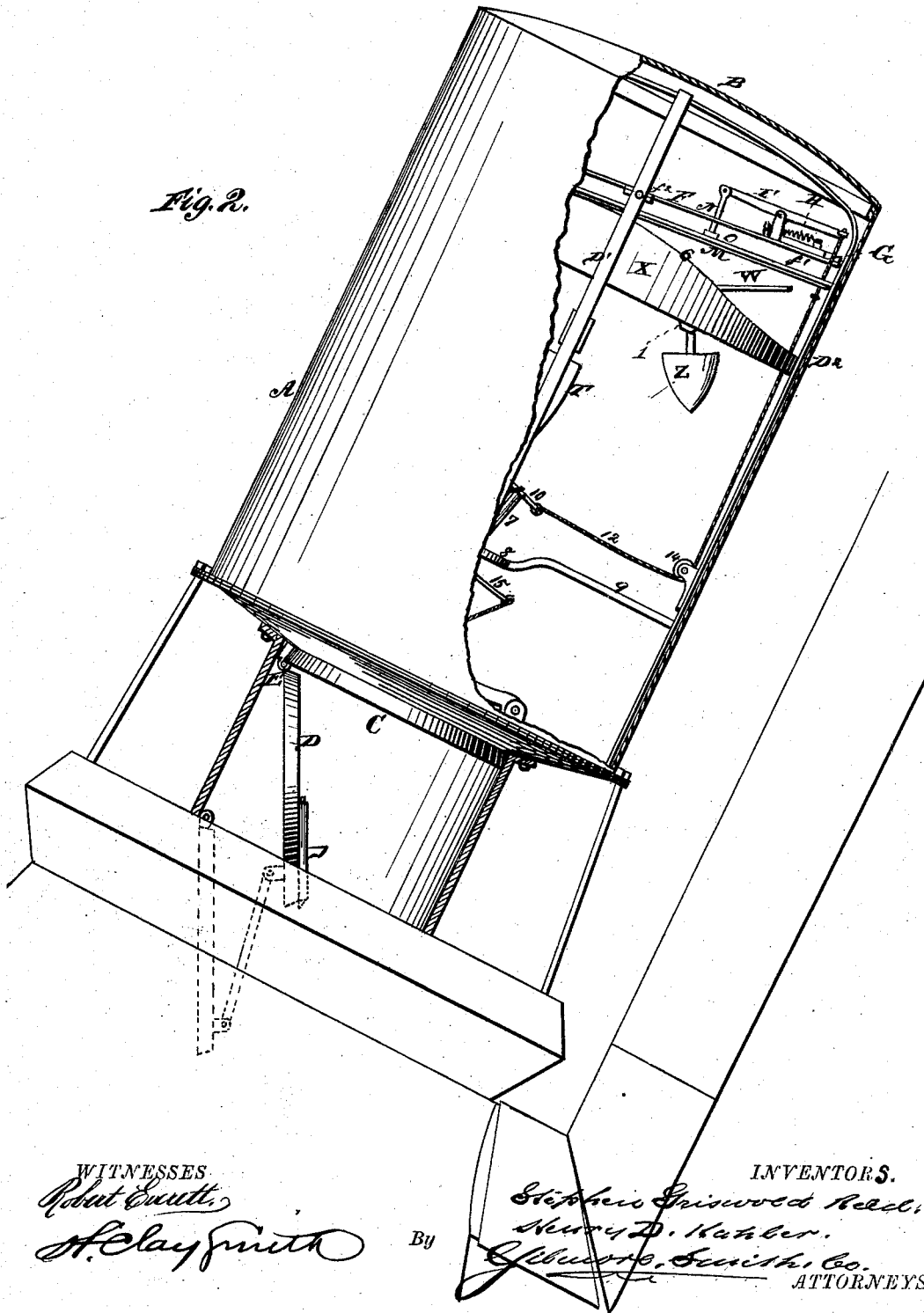

WITNESSES
Robert Smith,
H. Clay Smith

BY

INVENTORS.
Stephen Griswood Read,
Henry D. Kahler,
Gilbert S. Smith, Co.
ATTORNEYS.

S. G. READ & H. D. KAHLER.
Fire-Extinguisher for Car-Stoves.

No. 211,261.

Patented Jan. 7, 1879.

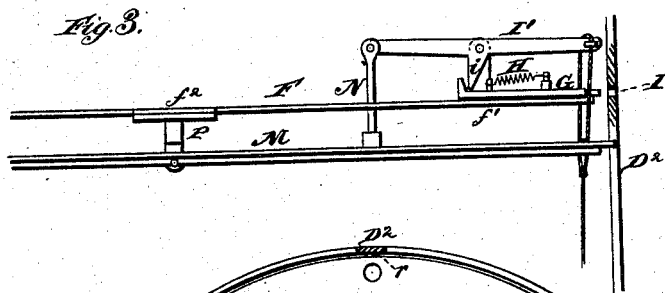

Fig. 4.

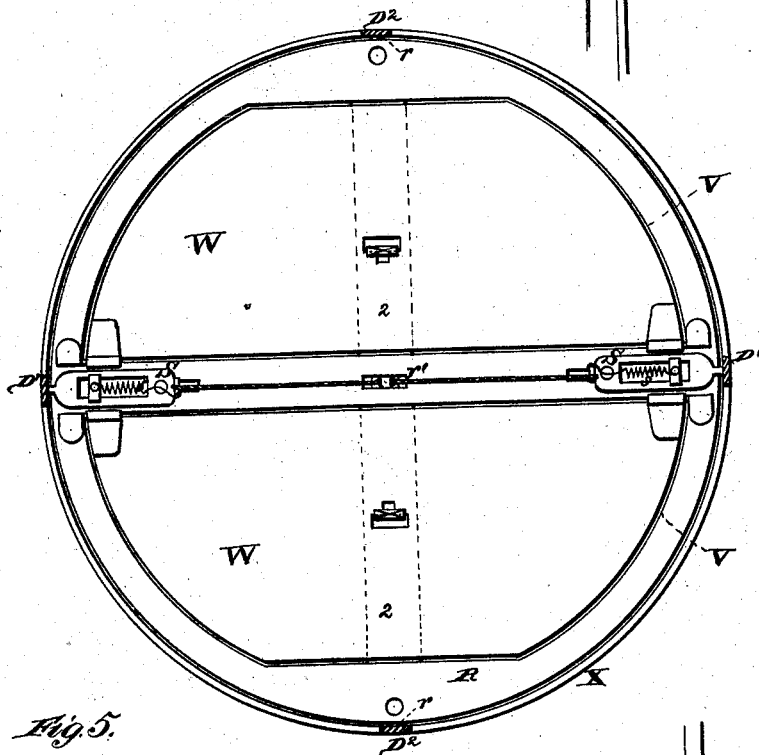

Fig. 5.

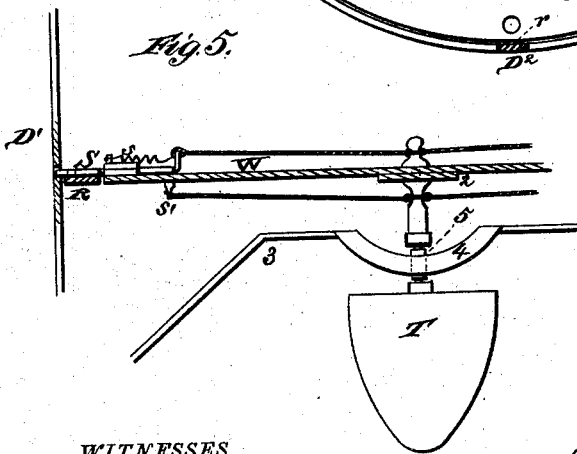
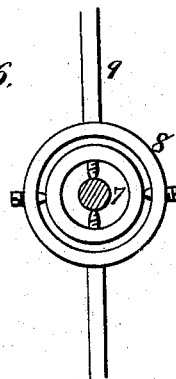

Fig. 6.



WITNESSES
Robert Everett
Alay Smith

By

INVENTORS.
Stephen Winwood Read.
Henry D. Kahler.
Gilmore, Smith & Co.
ATTORNEYS

UNITED STATES PATENT OFFICE.

STEPHEN G. READ AND HENRY D. KAHLER, OF FAWN CREEK, KANSAS.

IMPROVEMENT IN FIRE-EXTINGUISHERS FOR CAR-STOVES.

Specification forming part of Letters Patent No. 211,261, dated January 7, 1879; application filed December 14, 1878.

To all whom it may concern:

Be it known that we, STEPHEN GRISWOLD READ and HENRY D. KAHLER, of Fawn Creek, in the county of Montgomery and State of Kansas, have invented a new and valuable Improvement in Fire-Extinguishers for Car-Stoves; and we do hereby declare that the following is a full, clear, and exact description of the construction and operation of the same, reference being had to the annexed drawings, making a part of this specification, and to the letters and figures of reference marked thereon.

Figure 1 of the drawings is a representation of a perspective view of our invention. Fig. 2 is a side elevation, partly in section; and Figs. 3, 4, 5, and 6, details.

Our invention relates to a water-reservoir adapted to operate in connection with a car-stove in such a manner as to automatically flood the fire in case of accident, collision, or the like; and the novelty consists in the construction and arrangement of parts, as will be more fully hereinafter set forth.

In carrying out our invention we employ a water-tight reservoir, having an automatic valve in the bottom, operated by the force of the contained water acting upon certain hinged doors, pivoted plates, &c., as will be presently set forth, such doors, plates, &c., being connected to the automatic valve by cords, and being held fast in closed position by weighted levers having proper catches, but being released by the action of said levers when the device departs in any great degree from a vertical position.

The object of the invention is to provide a device which will store water in a reservoir above the car-stove, and retain such water in the reservoir so long as the apparatus retains a vertical position, but will, in case the car leaves the track and capsizes, automatically release said water and flood the fire, a suitable peculiar chute connecting the water-outlet with the top opening in the stove.

In describing our invention it will be understood that the stove-cover is hinged to the periphery of the top opening in the stove and falls inward. It is, when in a closed position, suspended from the falling automatic valve of the reservoir in such a manner that when the

said valve is released from its catch holding the chute leads uninterruptedly from the reservoir to the fire.

Referring to the drawings, A represents a closed vessel, tank, or reservoir, having a removable cover, B, and designed to contain water. In the bottom of said tank is formed an aperture, C, provided with a falling hinged valve, D, hinged at E to said base or bottom, and is connected to the hinged stove-cover (not shown) by a suitable loose link or connection, which cover is hinged to the stove-casing similarly to the valve, so as to move with said valve and open or close the aperture at the top of the stove, as more fully herein-after specified. To the base of the reservoir is secured a frame composed of four standards, which are preferably constructed of two bent metal rods, D¹ D², crossing each other at right angles and secured together at *d*, as shown, and having secured to them near the top a circular band, X, the construction and purpose of which will be more fully herein-after explained.

The letter F represents a metallic plate or section, constructed with four radial arms, *f f* and *f¹ f¹*, those *f f* of which are pivoted at their ends to the standards D¹ D¹, and those *f¹ f¹* set between the standards D² D², and are provided with reciprocating spring-latches G, which are held in a closed condition by the constant force of the springs H, so that their ends enter the apertures I in the standards D² D² and hold the plate F in a horizontal position.

To the arms *f¹ f¹*, at each side of the reciprocating latches, are secured upright standards K K, between which are pivoted the levers I', each of which is provided with a downwardly-extending arm, *i*, engaging the latches, and serving to shift the same as the levers are operated in an oscillatory manner to lock or unlock the latches. The outer ends of said levers are connected by means of cords with an oscillating disk, M, suspended between the standards; and to the inner ends of said levers are pivoted the drop-arms N, passing loosely through the plate or section F, and seated in bearings O on the upper surface of the disk M, the cord serving to depress the outer end of one of the levers as the disk M is depressed

at one side, and the drop-arm N to elevate the inner end of the opposite lever as the disk M is elevated at the opposite side, and vice versa, so as to operate the levers simultaneously to retract the latches and allow the radial plate to turn on its pivot.

The disk M is suspended from the plate F by a loose hanger, P, depending from the center of the said plate; and the arms *ff* of said plate are provided with downwardly-extending projections *f² f²*, sitting in bearings *mm* on the upper surface of the disk M, serving as guides to control and limit the play of the disk M with respect to the arms *ff*.

R represents a metallic disk, which is horizontal when in a normal condition between the standards and within the band X, and which is pivoted to the standards D² D² at *r*, and capable of oscillating freely on its pivots unless confined, as hereinafter explained. At the sides of the disk R, adjoining the standards D¹ D¹, are located the reciprocating spring-latches S S, which are held with a constant force by springs *ss*, so that their ends enter the apertures *d' d'* in the standards D¹ D¹, and to lock the disk R in a horizontal position.

At the center of the disk R is formed a slot, *r'*, in which is pivoted a weighted lever, T, the upper end of which projects through and above the said disk R, and is connected by cords, or their equivalents, to the latches S S, the said lever, immediately below the said disk, being connected to studs *s' s'*, extending below the plate and projecting from said latches S S, the upper cord of one latch serving to withdraw one latch when the lever is oscillated in one direction, and the lower cord serving to withdraw the opposite latch by the same movement, so as to shift both simultaneously to release the disk R and permit it to oscillate, as and for the purpose hereinafter explained.

The disk R is provided with two semicircular, or approximately semicircular, apertures, V, in which are located hinged doors or gates W, of corresponding shape, which close said apertures when in a normal position, and are held closed by means of weighted levers Z Z, pivoted in bearings 1 1 in the transverse bars 2 2, and provided with bolt-heads, adapted to enter and engage T-shaped slots in the gates or doors, the slots being so arranged relatively to the bolt-heads of the levers that when said levers are in a vertical position the shank of the lever will pass through the shank of the T-shaped slot, so that the head of the lever will lock the gate or door down to its seat, and when the lever is thrown out of a vertical position in one direction the shank of the lever will fall into the transverse portion of the T-shaped slot, allowing the slot to pass over the head and release the gate, as and for the purpose more fully hereinafter specified.

Below the disk R and secured to the standards D¹ D¹ is a diametrical brace, 3, provided with curved guides 4 4, between which the weighted lever T plays, said lever being pro-

vided with friction-rollers 5 5, which travel in contact with said guides, for the purpose of reducing the friction to a minimum.

The circumferential band X is of such configuration, as shown at 6 6 in the drawings, as to conform to the line of the raised edge of the disk R, to prevent the passage of water between said raised edge and the circumference of the chamber or band, in order that the full force of the contained water may be utilized.

The figure 7 represents an upright rod, mounted in a universal bearing, 8, supported between the standards D² D² by means of a diametrical bar, 9. Said rod has secured to its upper end a plate, 10, from which extend radially four cords, 11 11 and 12 12, two of which pass around pivoted pulleys 13 13, secured to the standards D¹ D¹, and extend upwardly through the disk R, and are secured to the disk M, the cords 12 12 passing over similar pulleys 14 14, secured to the standards D² D² and connecting with the disk R at opposite sides. The lower end of the rod 7 is provided with two cross-arms, 15, from the ends of which extend a series of cords converging to a common center, 16, from which extends a cord through an aperture in a transverse brace, 17, extending across the aperture in the base of the apparatus. The lower end of this cord is connected to one end of a lever, 18, which is pivoted to a standard, 19, secured to the base, the short arm of said lever being provided with a friction-roll, 20, which is adapted to engage a spring-latch secured to the hinged valve D, which closes the aperture at the base of the apparatus, and to release the same as the apparatus is thrown out of a vertical position, as will be described in the ensuing description of the operation of the apparatus.

The operation of our invention is as follows: The tank or reservoir, with its inclosed devices, is secured above the top of a car-stove, and the valve at the base of the same is secured to a downwardly-opening hinged stove-cover. The tank is then filled with water. When, by reason of any accident, the car in which the stove having our improvements attached is overturned or thrown out of its natural position, the tank is thrown out of its vertical position, the weighted levers, holding their vertical positions, release the gates, doors, &c., from their catches, and the weight of the contained water, assuming its level within the tank, forces the proper gates away from their natural positions, and this action, through the medium of the connecting-cords, releases the valve in the base of the device, which, falling with the connected stove-top, serves to flood the fire with water, whereby such fire will be extinguished and all danger of conflagration entirely obviated.

The tank is set at a sufficient distance above the stove to allow an air-space between to prevent the water from becoming heated. The weights of the levers act as stops to prevent the splashing of the water.

The chute leading from the aperture in the

base of the apparatus to the stove has a flat surface, to allow the circular valve to fall close to that side, and afford the entire area to be used by the water.

We are aware that it is not broadly new to operate valves in devices for a similar purpose automatically, such operation being caused by the position of the car when it leaves the track.

What we claim as new, and desire to secure by Letters Patent of the United States, is—

1. A water-reservoir provided with an automatic valve, said valve being released by the weight of the contained water acting upon connected pivoted gates, doors, &c., as and for the purpose described.

2. In a fire-extinguisher for railroad-cars, a water-tank provided with a valve adapted to be automatically opened by the weight of the water contained within the tank acting upon pivoted gates, &c., connected with said valve, when the device is thrown out of its normal position, substantially as and for the purposes set forth.

3. In a fire-extinguisher, the automatic valve D, combined with the hinged stove-cover, to which it is loosely attached, as and for the purpose specified.

4. The valve D and its securing device com-

bined with the disk R and their connections, as set forth.

5. The valve D and the catch, in combination with the vertical rod 7, in universal bearings 8, the disks R and M, and their connections, as set forth.

6. The pivoted disk R, having hinged gates W and catches S, in combination with the valve D and the connections, as set forth.

7. The combination of the plate F, disk M, and disk R, with their catches, with the valve D and connections, as specified.

8. The disk R, weighted lever T, and cord 11, in combination with the valve D and operating-trigger, as shown and described.

9. The disk R, having gates W and latches, in combination with the weighted levers Z, as and for the purpose set forth.

10. The disk R, having gates W, the levers Z, and lever T, in combination with the disk M and valve D and connections, as set forth.

In testimony that we claim the above we have hereunto subscribed our names in the presence of two witnesses.

STEPHEN GRISWOLD READ.

HENRY D. KAHLER.

Witnesses:

C. A. TUCKER,

E. FOSTER.