

J. C. SCHMIDT.  
Spring Bed-Bottom.

No. 211,264.

Patented Jan. 7, 1879.

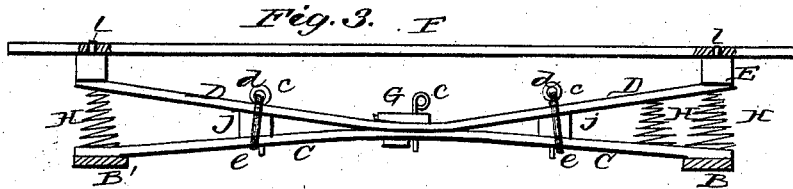
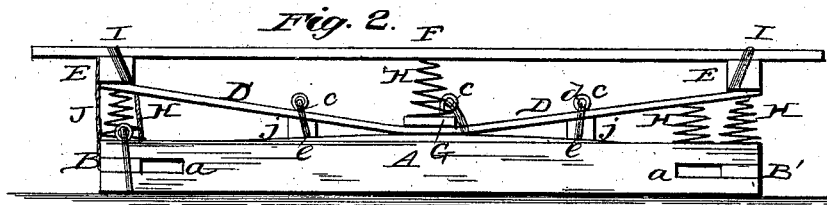
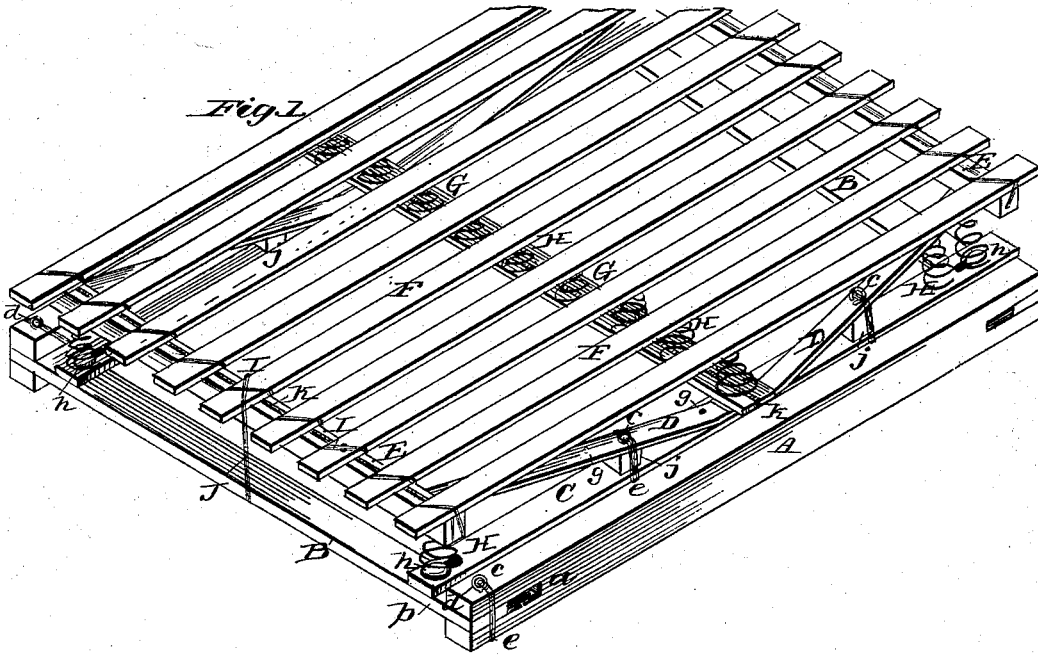

Witnesses

George. Pinkenburg

Fred. G. Dietrich

Inventor

John C. Schmidt  
By Caldwell,  
Atty.

J. C. SCHMIDT.  
Spring Bed-Bottom.

No. 211,264.

Patented Jan. 7, 1879.

Fig. 4.

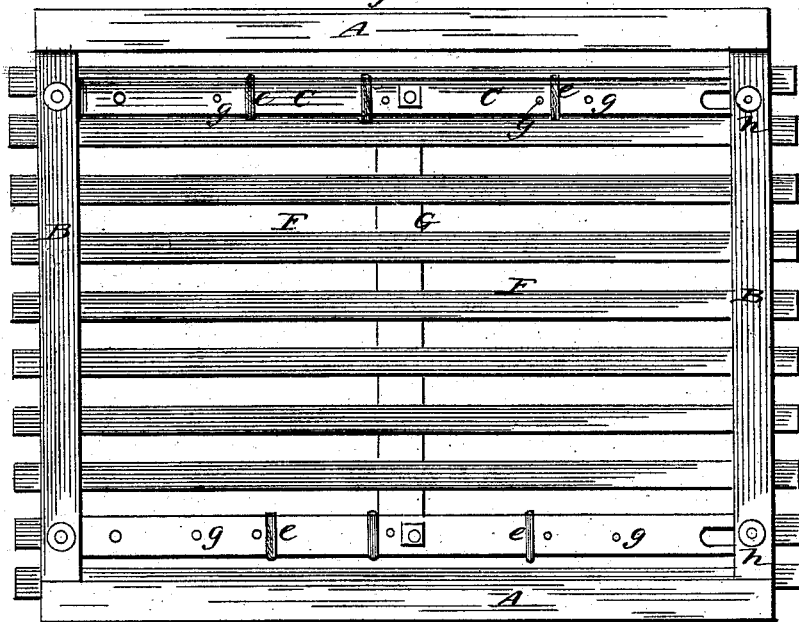

Fig. 5.

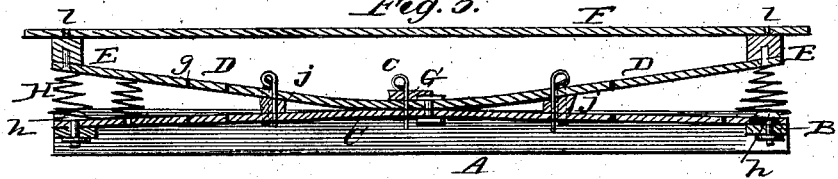

Fig. 6.

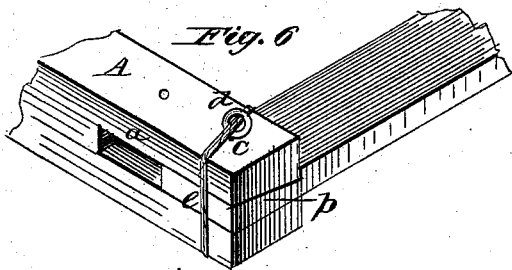

Fig. 7.

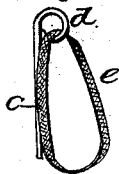

Fig. 9.

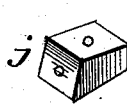
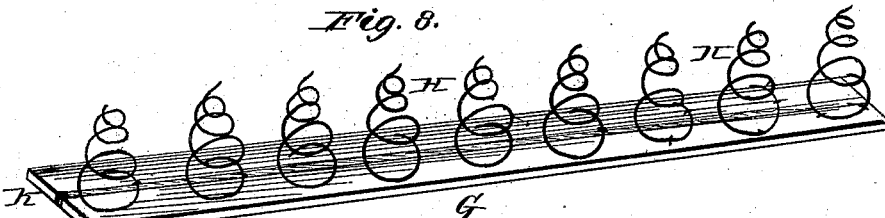

Fig. 8.



Witnesses:  
Det. G. Dieterich  
George. Pinkenburg

Inventor  
John C. Schmidt  
By C. C. Snow & Co.  
Attys.

# UNITED STATES PATENT OFFICE.

JOHN C. SCHMIDT, OF NEW CASSEL, WISCONSIN.

## IMPROVEMENT IN SPRING BED-BOTTOMS.

Specification forming part of Letters Patent No. 211,264, dated January 7, 1879; application filed October 23, 1878.

*To all whom it may concern:*

Be it known that I, JOHN C. SCHMIDT, of New Cassel, in the county of Fond du Lac and State of Wisconsin, have invented certain new and useful Improvements in Spring Bed-Bottoms; and I do hereby declare that the following is a full, clear, and exact description of the invention, which will enable others skilled in the art to which it appertains to make and use the same, reference being had to the accompanying drawings, which form a part of this specification.

Figure 1 is a view in perspective of a bed-bottom embodying the improvements in my invention. Fig. 2 is a side elevation of the same. Fig. 3 is a detail view of one pair of the side supporting-slats. Fig. 4 is a bottom-plan view. Fig. 5 is a longitudinal sectional view of the side supporting-slats. Fig. 6 is a detail view of the side rails and cross-bars, showing the adjustable connection between them. Fig. 7 is a view in perspective of the pin and elastic band for holding it to place. Fig. 8 is a perspective view of the central cross-slat and spiral or coiled springs, and Fig. 9 is a perspective view of the beveled block employed in expanding and contracting the side supporting-slats.

This invention has relation to spring bed-bottoms; and it consists in the improvements in the construction of the same hereinafter fully described, and particularly pointed out in the claims.

In the accompanying drawing similar letters of reference indicate corresponding parts in the several figures.

The side rails A of the bed-bottom are recessed at each end. These recesses *a* are preferably made flaring or beveled from the inner toward their outer sides in order to receive the dovetailed tenons *b* on the ends of the head and foot rails B B'. Pins *c*, having eyes *d* and elastic encircling bands *e*, are employed to secure the head, foot, and side rails together through the perforations in the same. Side supporting-slats C D are bolted together at their centers and perforated at proper places between their ends, as shown at *g*, and the slat C is slotted or perforated at each end, in order that it may be adjustably secured to the head and foot rails by bolts and nuts *h*. The upper supporting-slat, D, is secured firmly to

the under faces of the cross-bars E, which form the supports for the longitudinal slats F, upon which the mattress rests, by screws, which may be loosened and tightened to vary the tension of the slats D.

Blocks *j*, having two beveled and two plane faces, one of the beveled and one of the plane faces being longer than the other corresponding face, are perforated at right angles to receive pins *c*, hereinbefore described. These blocks *j* are inserted between the slats C and D to spread them apart, and may be located between the perforations to receive the pins *c* at any desired point between the centers and ends of the slats C D.

The blocks *j* may be placed with either of their opposite plane faces next to the surfaces of the slats C D in order to increase or diminish the distance between said slats.

The elastic bands *e* hold the pins *c* in place until they are designedly removed, which may be readily accomplished by stretching the bands.

A central cross-slat, G, is removably secured to the side supporting-slats C D, and resting upon the latter, by the pins *c e*. The cross-slat G is provided with springs H. The central slat, G, and the cross-bars E are traversed longitudinally upon their upper faces by cords *k*.

The slats F are perforated near each end, and pins *l* in the upper faces of the cross-bars E enter these perforations. Cords I are whipped around and over the slats F and cross-bars E, and these, together with cord *k*, prevent noise and rattling.

One or two springs, H, are inserted between the slats C and D at their ends to form supports and insure greater elasticity at the corners.

It frequently occurs that one corner or one end of a spring bed-bottom sags or becomes lower than the other portions, and it then becomes necessary to level it. To provide against this contingency I have made the end rails B B' adjustable, in order that they may be moved inwardly or toward the center of the bottom at either or each of the corners, and there secured. This is accomplished through the tenons and recesses in the end and side rails, and the pins *c*, bolts and nuts

*h*, and the slots or perforations in the ends of the side supporting-slats *C*. Cords or bands *J* are employed at each end of the bed-bottom to limit the upward spring of the same.

It is necessary, in order that a bed-bottom may be as nearly perfect as possible, that it should be so constructed that it may be regulated to accommodate different weights. In this construction it may be done by removing, or inserting if it has previously been removed, the central slat provided with the springs *H*; also, by adjusting the beveled blocks *j*. The advantages of a spring bed-bottom of this construction are obvious.

Having thus fully described my invention, what I claim as new and useful, and desire to secure by Letters Patent, is—

1. In a bed-bottom, the side supporting-slats *C D*, connected at their centers, the lower one slotted or perforated at its ends, in combination with the adjustable end rails *B B'*, substantially as set forth.

2. In a bed-bottom, the combination, with the side supporting-slats *C D*, of the expansion-blocks *j* and pins *e*, having elastic band *e*, substantially as set forth.

In testimony that I claim the foregoing as my own I have hereto affixed my signature in presence of two witnesses.

JOHN C. SCHMIDT.

Witnesses:

JOHN REISSE,

CHS. REISSE.