

A. H. WAGNER.  
Grinding-Mill.

No. 211,281.

Patented Jan. 7, 1879.

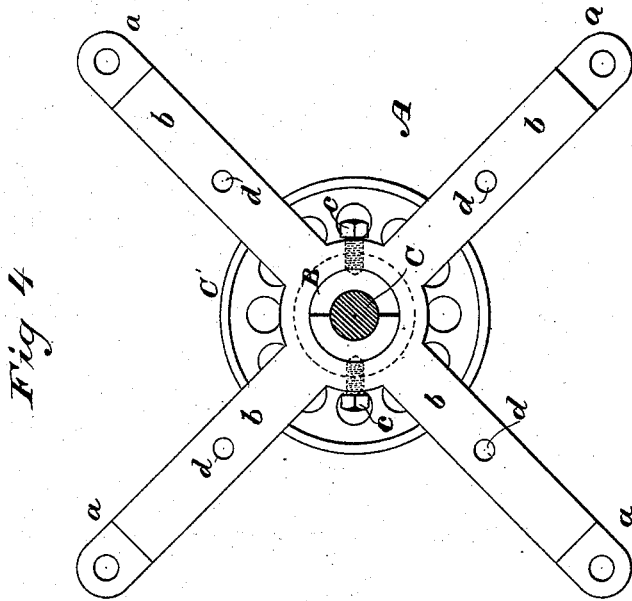

Fig 4

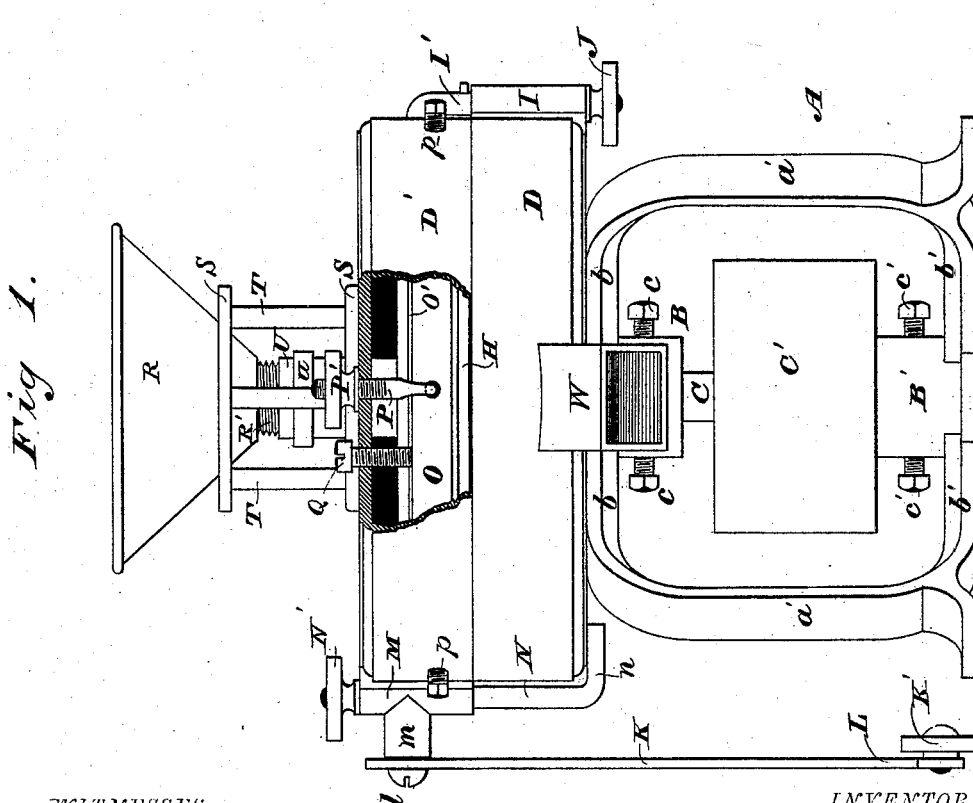

Fig 1.

WITNESSES

*Wm A Skinkle*  
*Geo W Orick.*

INVENTOR

*Ausbert H Wagner*

By his Attorneys

*Baldwin, Hopkins & Peyton.*



A. H. WAGNER.  
Grinding-Mill.

No. 211,281.

Patented Jan. 7, 1879.

Fig 5.

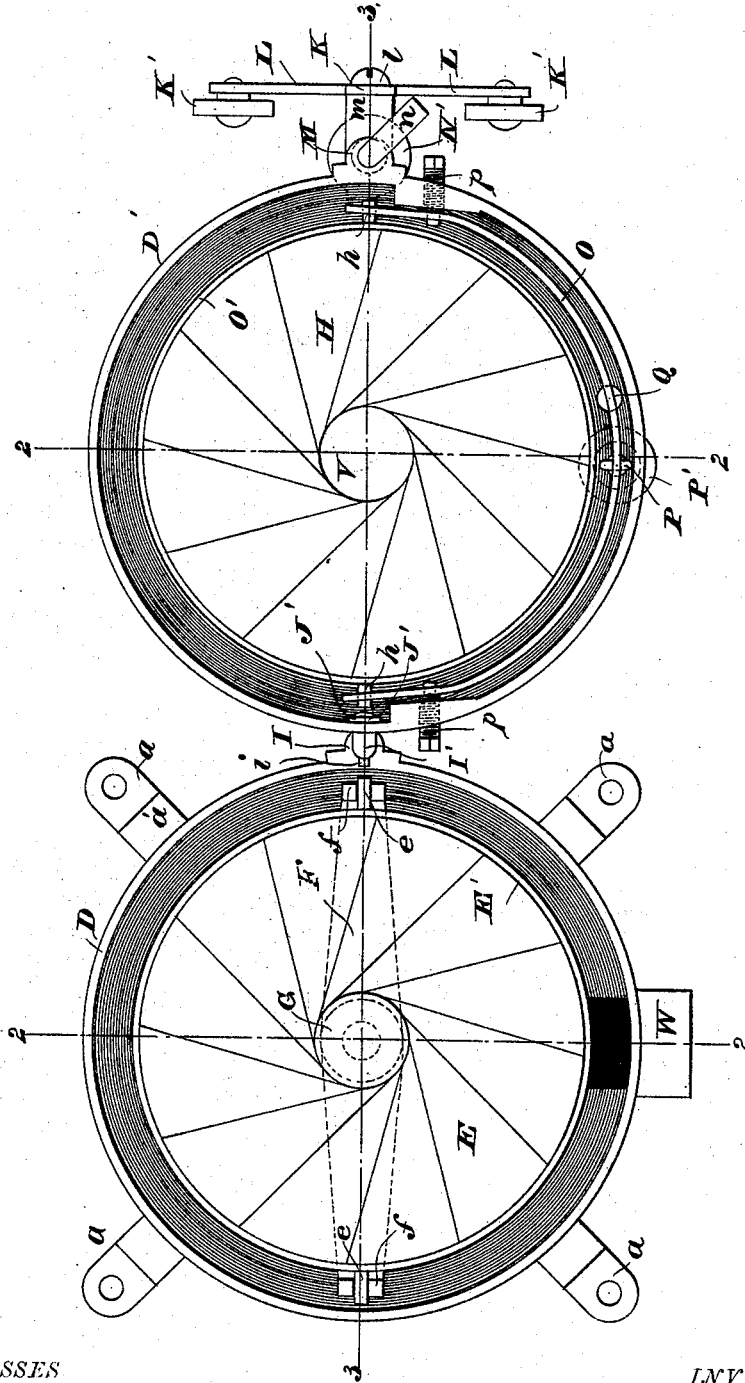

WITNESSES

*Wm A Shinkles,*  
*Geo W Brick.*

INVENTOR

*Ausbert H Wagner.*

By his Attorneys

*Galwin, Hopkins & Peyton.*

A. H. WAGNER.  
Grinding-Mill.

No. 211,281.

Patented Jan. 7, 1879.

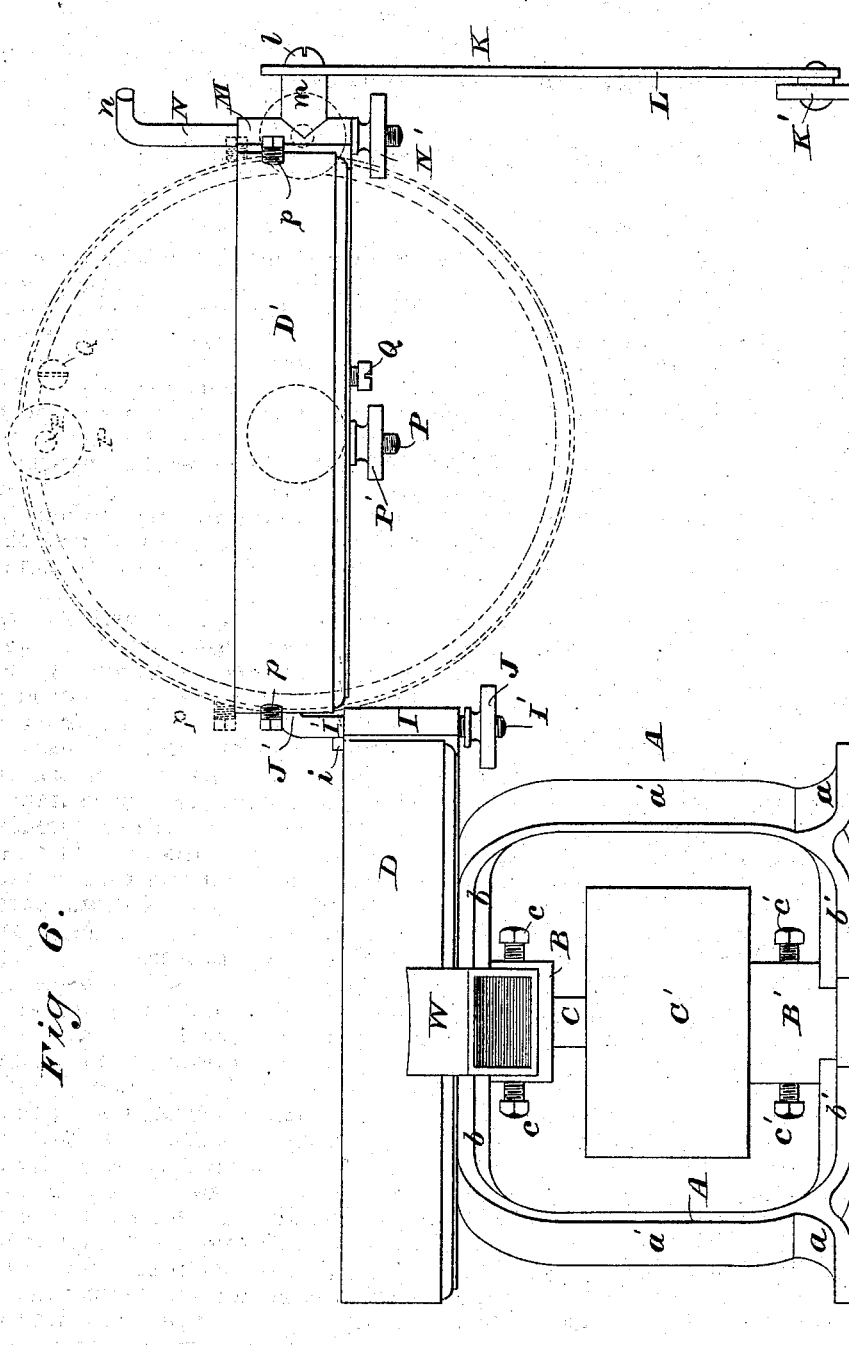

Fig. 6.

WITNESSES

*Wm A Skinkley*  
*Geo W Buck*

INVENTOR

*Ausbert H Wagner.*

By his Attorneys.

*Baldwin, Hopkins & Peyton.*

# UNITED STATES PATENT OFFICE.

AUSBERT H. WAGNER, OF CHICAGO, ILLINOIS, ASSIGNOR TO ANNA G. WAGNER, OF SAME PLACE.

## IMPROVEMENT IN GRINDING-MILLS.

Specification forming part of Letters Patent No. 211,281, dated January 7, 1879; application filed November 18, 1878.

*To all whom it may concern:*

Be it known that I AUSBERT H. WAGNER, of Chicago, in the county of Cook and State of Illinois, have invented certain new and useful Improvements in Grinding-Mills, of which the following is a specification:

My invention relates chiefly to improvements in mills of the class known as "horizontal mills," or those in which the runner revolves about a vertical axis, and particularly to that type of such class in which the under stone is the runner.

My objects, mainly, are to provide a mill in which the upper or stationary stone can quickly, and with but slight exertion or physical labor, be adjusted and supported in such position relatively to the runner or under stone as to fully expose the face of the runner, and to adapt the stationary stone to be readily turned over or face up, and to be so supported for dressing.

My objects, further, are to render the stones self-adjusting relatively to each other; to provide simple means for adjusting the one stone toward or away from the other, so as to bring their faces or grinding-surfaces nearer together or farther apart, to grind coarser or finer; to improve the supporting-frame or "husk;" to provide simple and secure connections between the upper and lower sections of the casing in which the stones are mounted, and, generally, to improve and perfect the mill as to details.

The improvements claimed consist in a novel organization of parts and in certain combinations of devices, hereinafter first fully described, and then specifically designated.

In the accompanying drawings I have shown all my improvements as embodied in a portable mill. Some of my improvements may, however, obviously be used without the others, or in connection with a mill, either stationary or portable, differing in some respects from that therein represented, and hereinafter particularly described.

Figure 1 is a view in elevation, showing the mill in running order, with a portion of the upper section of the casing broken away to illustrate the manner of hanging and adjusting the upper stone; Fig. 2, a vertical section in the plane of the lines 2 2 of Figs. 3 and 5, the

stones and their immediate connections being shown in elevation; Fig. 3, a vertical section at a right angle to that shown by Fig. 2, and on the line 3 3 thereof, parts being broken away below the casing. Fig. 4 is a plan or top view of the main frame or husk, the mill being removed and the spindle in section beneath the casing. Fig. 5 is a plan or top view, showing the upper stone as swung around and turned face up; and Fig. 6 is a view in elevation, showing the parts in the position they occupy in Fig. 5, the dotted lines representing the upper stone and its section of the casing as in the act of turning.

The support, main frame, or husk A for the stones is of skeleton form, cast in a single piece, braced or girdered at top and bottom, and adapted to be secured in place by screws passing through its feet *a*. This frame A, which I term a "doubly-girdered husk," is provided with two bearings, B B', the top one, B, projecting downward from the centers of the radiating brace-arms or girders *b*, four of which are shown in this instance; but three would answer. The bottom bearing or step, B', is vertically beneath or in line with the top bearing, and projects upward from the centers of the radiating lower brace-arms or girders, *b'*, which connect, by the side posts or uprights *a'*, with the top girders or braces, *b*. The driving shaft or spindle C is stepped at its lower end in the bearing B', and passes through the upper bearing, B. Lining-blocks or sectional bushings are secured in the bearings B B' by set-screws *c* and *c'*, as usual. A belt-pulley, C', is detachably fastened to the spindle, so that it receives the driving-band to drive the spindle. A set-screw serves to bind the band-wheel to the spindle and admit of its ready separation therefrom. By loosening this screw the spindle may be slid through the pulley and upper bearing, when desired, to disconnect the parts to afford access to the bearings, &c.

The casing for the stones is mounted upon top of the doubly-girdered husk—that is, upon the horizontal flat surfaces of the top girders or brace-arms, *b*. Screws pass through the bottom of the runner-enveloping portion or lower section, D, of the two-part casing D D' and into the taps or female screws *d* of the

husk-top. A secure and firm connection between the husk and lower section of the casing is thus secured, while admitting of the ready separation of the parts for transportation, repairs, &c.

The runner or lower stone, E, is driven from its periphery by the spindle C through or by way of a bridge-bar or cross-head driver, F, having forked or slotted short uprights or lugs *ff* at its ends outside of and close to the vertical wall or peripheral edge of the runner at diametrically-opposite sides thereof. Short journals or trunnions *ee*, at the stone's periphery upon a band, E', enter the slots or forks of the lugs *ff* and prevent any horizontal or rotary movement of the stone E independently of the driver or cross-bar F of the driving-shaft C. These trunnions rest in the lugs slightly above the bottoms of their slots or junctures of their forks, (see dotted lines, Fig. 3,) and the upper rounded or pointed end of the spindle C enters a step-piece or projects into a socket in the under side of a step-disk or eye-plate, G, secured centrally in the eye or opening G' in the runner. The weight of the runner is thus supported by, and end thrust brought directly upon, the spindle, preventing undue strain upon the driver F, and admitting of the self-adjustment or rocking of the stone E in every direction. The stone is thus free to cant or adjust itself in all directions to a limited but sufficient extent relatively to the upper or stationary stone, H. The rocking of the running stone upon the spindle is limited in one direction by the amount of play downward of the trunnions in the slots of the lugs *ff*; but practically the amount of movement is ample to meet all requirements of adjustment, when the stone is running, to allow of the escape of clogging matter, &c.

The upper or stationary stone, H, is hung in its section D' of the divided casing, in the manner hereinafter to be explained, and this upper section of the casing has a doubly-hinged connection with the lower section, D. The jointed connection between the sections is such as to admit of both a horizontal or swinging movement and a vertically rocking or turning movement of the upper section and its stone upon or relatively to the lower section and the running stone.

As shown by the drawings, the hinged connection in this instance is formed by a double swivel-joint, a long upright bearing or tubular bracket, I, being provided upon the lower section, D, of the casing with a turning-bolt or swivel-rod, I', fitting loosely therein, and having a screw-thread upon its lower end provided with a milled clamp-wheel or pinch-nut, J, by which to draw down the bolt and bind its cross-pin or lug *i* upon the top of the sleeve-bearing or tubular bracket to lock the bolt against turning. At its upper end the swivel-bolt is cranked or bent at a right angle and forms a trunnion or swivel-pivot, J', fitted in a bearing in the upper section, D', of the casing.

From the above description it will be seen

that when the parts are in the locked position, as shown by Fig. 3, the pinch-nut J bears against the under side of the lower casing at the base of the bearing I, and draws the lug *i* forcibly down upon the top of the bearing, thus preventing any accidental turning of the swivel-bolt I', as well as guarding against the rocking of the casing-section upon the swivel crank or pivot J'.

By loosening the nut the upper half of the casing can be swung out and then rocked or turned over, as seen in Figs. 5 and 6, and when so adjusted any horizontal swing of the casing-section or turning of the swivel-rod can be prevented simply by tightening the nut J.

To facilitate the adjusting of the upper stone so as to uncover the lower stone and expose the faces of both stones, I provide a traversing support for the section D' of the casing at the side opposite its hinged connection with the lower fixed section, D. This support, as shown in the drawings, consists of a truck-frame or upright, K, forked at its lower end, and provided with rollers K' K' at the lower ends of its forks L L. At its upper end the traversing support is pivoted to the casing-section D' diametrically opposite to the pivot J' of the doubly-swiveling connection between the two sections of the casing. A lug or trunnion, *m*, receives the pivot bolt or screw *l*, which makes the jointed connection between the support and upright-frame. The trunnion *m* projects from a sleeve-bearing or tubular bracket, M, upon the casing-section D', similar to that, I, upon the fixed section, D, of the casing. A swiveling-bolt or turning rod, N, in this bearing has one of its ends bent or cranked to form a hook, *n*, and at its opposite end the rod is provided with a screw-thread and milled wheel or pinch-nut, N'.

From the above description it will be seen that when the casing-sections are adjusted together in the working position, with the hook *n* beneath the bottom of the lower or fixed section, the tightening of the nut N' serves to clamp the parts securely to each other. When it is desired to swing the upper section of the casing out from the lower section the nut N' is loosened and the bolt N turned to bring its hook from beneath the fixed section. This having been done, and the hinged joint between the sections also loosened, as before explained, the upper section and the stationary stone may be swung around on the swivel-rod I' with but slight exertion on the part of the attendant, as the casing-section and stone are balanced on the pivotal supports J' and *l*, and the weight of the parts supported by the truck-frame or traversing support K moving freely upon the floor on the rollers K'. No great exertion is required to turn over the upper section and stone, H, for inspection, dressing, &c. Before turning the stone the nut J is tightened to prevent any horizontal movement of the parts on their hinged connection with the fixed section, D. The stone E and casing-section D may easily be held in the

adjusted position by the attendant, or may be propped in position to facilitate dressing. The traversing support or truck-frame may be detached from the casing by removing its screw-pivot *l* if desired.

The stationary or upper stone, H, is hung by peripheral journals or trunnions *h h* in an adjustable frame or doubly-fulcrumed lever-support, O. The trunnions by which the stone is hung and balanced are provided on the band O', which encircles the stone. The adjusting frame, or support O consists of a bowed or curved bar of about semicircular shape extending about half-way around the stone, between it and the casing D', and fulcrumed so as to be capable of rocking vertically, near its ends, on the pivots *p p*, projecting inwardly from the casing's periphery at points opposite each other at corresponding distances from the ends of the adjusting-bar, and intermediate the stone-trunnions *h h* and middle of this bar or frame O. A hook-ended adjusting-rod or screw-bolt, P, engaging the frame O at its middle, and its adjusting and clamping nut P', on top of the casing, serve, in connection with a stop-screw, Q, passing down through the casing-top, to hold the frame O in any position to which it may be adjusted by rocking it on its fulcrums *p p*. The screw Q abuts against the top of the adjusting-frame or bow-shaped bar O, and prevents its movement in one direction, while the rod and its nut P' prevent movement in the other direction. The stone H is free to rock on its trunnions to be self-adjusting to the runner E, and the distance between the grinding-faces of the stones can quickly be changed as desired by adjusting the frame O.

The hopper R rests loosely upon and is supported in a skeleton frame consisting of the upper and lower bands or rings S S and connecting rods or pillars T, three or more in number. An extensible feed-tube, U, of the hopper serves to regulate the supply of grain, &c., to the stones. This feed-tube is screwed at its upper end, by its internal thread, to the short section of tube R', fixed to the hopper-bottom. A milled annular bead or fixed collar, *u*, on the lower or adjusting section, U, of the extensible supply-tube enables the attendant to regulate the feed readily.

The amount of grain or other substance supplied to the stones depends upon the distance between the bottom of the feed-tube and the top surface of the step plate or disk G in the central opening or eye G' of the runner E. The top of this step-disk is below the level of the runner's face or upper surface.

The tube U extends down into the central opening or eye V of the upper stone, and terminates at its lower end a short distance from the lower stone.

The skeleton hopper-supporting frame R S T rests loosely upon the top of the casing, so that it may be removed without delay when the upper casing-section and stationary stone are to be swung around and turned over.

The spaces between the rods or pillars T of the hopper-frame afford ample room for the attendant to take hold of the adjusting-collar *u* of the feed-tube, by inserting his hand between the pillars, to turn the lower tube upon the upper section or fixed tube, R', so as to cause the discharge end of the tube to approach or recede from the eye-piece or step-plate G, to decrease or increase the feed, as will readily be understood.

The grain or other substances, after being ground, issues from the casing by way of the spout W.

I do not broadly claim a casing for the stones made in sections and hinged together; nor do I claim, broadly, a stone hung upon pivots, so as to be self-rocking or adjustable relatively to the other stone; neither do I claim a loosely-supported hopper frame, nor every way of driving the runner from its periphery, nor, broadly, an extensible feed-tube.

I claim as of my own invention—

1. The combination, substantially as hereinbefore set forth, of the stationary upper stone, the lower or running stone, revolving about a vertical axis, the fixed section of the casing, in which the lower stone is mounted, and the adjustable section of the casing supporting the stationary stone and swinging horizontally about a hinged connection with the lower section of the casing.

2. The combination, substantially as hereinbefore set forth, of the two-part casing, the stationary stone supported in the adjustable section of the casing, the running stone in the opposite section of the casing, and the double-hinge connection between said sections, whereby the stationary stone may be swung horizontally and turned vertically to bring its face up by two movements of its section of the casing about its double-joint connection with the casing-section of the runner, for the purposes described.

3. The combination of the adjustable section, D', of the casing, the double hinge, by which to connect it at one side with the other section, D, of the casing, and the lug or trunnion *m*, on the side of the adjustable section opposite its hinge, to balance said section, substantially as hereinbefore set forth.

4. The combination, substantially as hereinbefore set forth, of the two-part casing, the opposite sections of which are adapted to support the one the stationary stone and the other the running stone, the hinged connection between said sections, by which one section may be swung around horizontally on the other, and the traversing support or truck-frame sustaining the adjustable section at the side opposite to that by which it is hinged to the remaining section.

5. The combination, substantially as hereinbefore set forth, of the two-part casing, the upper and lower sections of which, respectively, support the stationary stone and the running stone, the hinged connection between said sections, by which the upper section may

be swung around horizontally on the lower fixed section, and the traversing support or truck-frame sustaining the adjustable section at the side opposite that by which it is hinged to the fixed section.

6. The combination, substantially as hereinbefore set forth, of the two-part casing, the upper and lower sections of which are respectively adapted to support the stationary stone and the running stone, the hinge-connection between said sections, by which the upper section is adapted to turn vertically, and the traversing support or truck pivoted at top to the upper section of the casing opposite to or in line with the pivot about which said section turns vertically on its connection with the lower section.

7. The combination, substantially as hereinbefore set forth, of the fixed section of the casing, the adjustable section thereof, the combined vertical and horizontal hinge-connection or double-swivel joint *I' J'*, and its bearing in the fixed section.

8. The combination of the lower section of the casing, the bearing at its side, the swivel-bolt or turning rod mounted in said bearing, the upper section of the casing, pivoted upon the swivel-bolt and adapted to turn both horizontally and vertically, and the clamping-nut upon said swivel-bolt, these members being constructed and operating substantially as and for the purpose hereinbefore set forth.

9. The combination, substantially as hereinbefore set forth, of the adjustable section of the casing, the opposite section thereof, the stationary stone, the running stone, the combined double hinge and clamp connection between the sections, and means, substantially such as described, for clamping the sections of the casing together at the side opposite that at which they are both hinged and adapted to be locked to each other, whereby the adjustable section may be securely locked to the opposite section and is rendered capable of being swung around horizontally and turned over, as set forth.

10. The combination of the casing made in two parts and hinged together, the bearing *M*, for the turning clamping-rod in the upper section of the casing at the side opposite its hinged connection with the lower section, and the traversing support or truck-frame upon

which the trunnion *m*, projecting from said bearing, is pivoted, substantially as hereinbefore set forth.

11. The combination, substantially as hereinbefore set forth, of the lower section of the casing, rigidly connected with the husk, the spindle, the running stone, its trunnions, the step-disk or eye-plate, supporting the stone at its center upon the spindle, and the cross-head or driver having the slotted or forked uprights to receive the stone-trunnions, which rest in the slots of the driver ends above the bottoms thereof, for the purpose described.

12. The combination, substantially as hereinbefore set forth, of the casing, the husk to which the casing-bottom is rigidly connected, the stationary upper stone, the spindle, and the runner or lower stone driven from its periphery by the spindle, supported at its center thereon, and having the capacity of vertical self-adjustment, relatively to the upper stone, in all directions, by rocking on the spindle without interfering with its driving connections therewith.

13. The combination, substantially as hereinbefore set forth, of the stationary stone, its trunnions, the casing-section, the semicircular adjusting-frame or curved bar inside the casing, and in the ends of which the stone is hung and balanced by its trunnions, the adjusting-rod connected with said frame at its middle, and the pivots by which the frame is fulcrumed in the casing intermediate its ends and the adjusting-rod, for the purpose described.

14. The combination of the stationary stone provided with trunnions, its casing, the adjusting-frame *O*, in the ends of which the stone-trunnions are supported, the pivots upon which the frame is fulcrumed, the adjusting-rod hooked to said frame at its middle, the clamping-nut on said rod above the casing, and the stop-screw bearing upon the adjusting-frame at the side of said nut, these members being constructed and operating substantially as hereinbefore set forth.

In testimony whereof I have hereunto subscribed my name.

AUSBERT H. WAGNER.

Witnesses:

GEO. C. THOMPSON,  
GEORG BERNHARDT.