

C. WHEELER, Jr.  
Harvester-Droppers.

No. 211,286.

Patented Jan. 7, 1879.

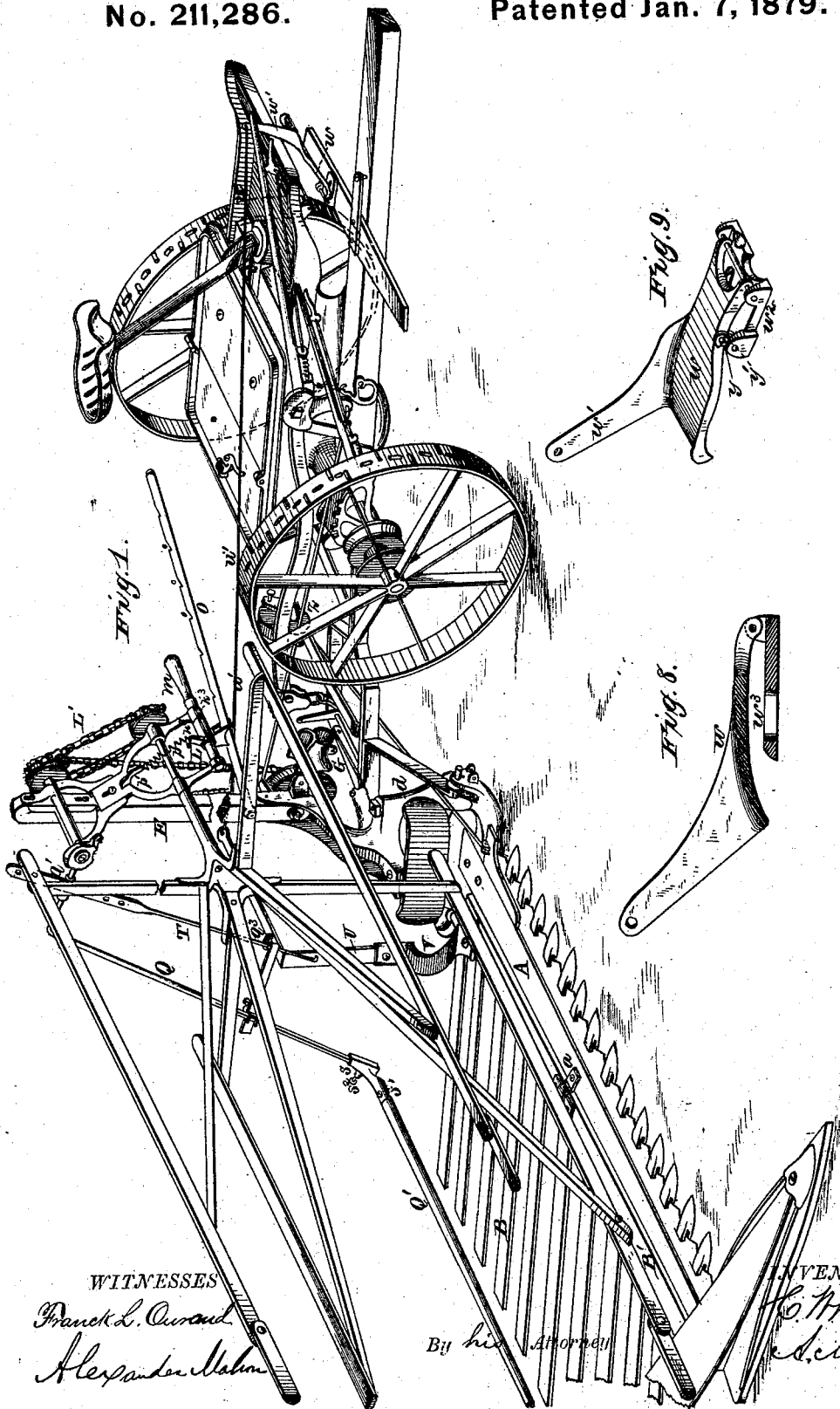

WITNESSES  
Frank L. Curran  
Alexander Mahan

By his Attorney

INVENTOR  
C. Wheeler Jr.  
A. M. Smith

C. WHEELER, Jr.  
Harvester-Droppers.  
No. 211,286. Patented Jan. 7, 1879.

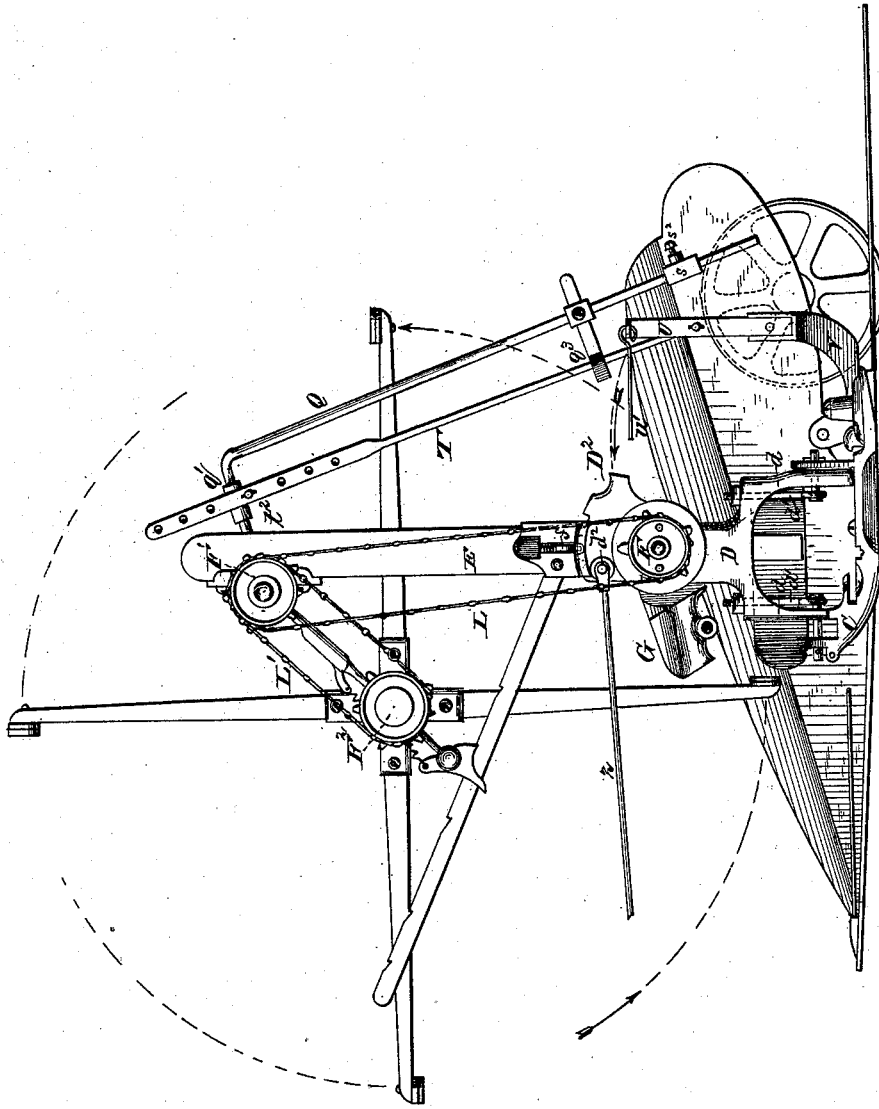

Fig. 2.

WITNESSES

*Frauct L. Curandy*  
*Alexander Mahon*

By his Attorney

INVENTOR

*C. Wheeler, Jr.*  
*A. M. Smith*

C. WHEELER, Jr.  
Harvester-Droppers.  
No. 211,286. Patented Jan. 7, 1879.

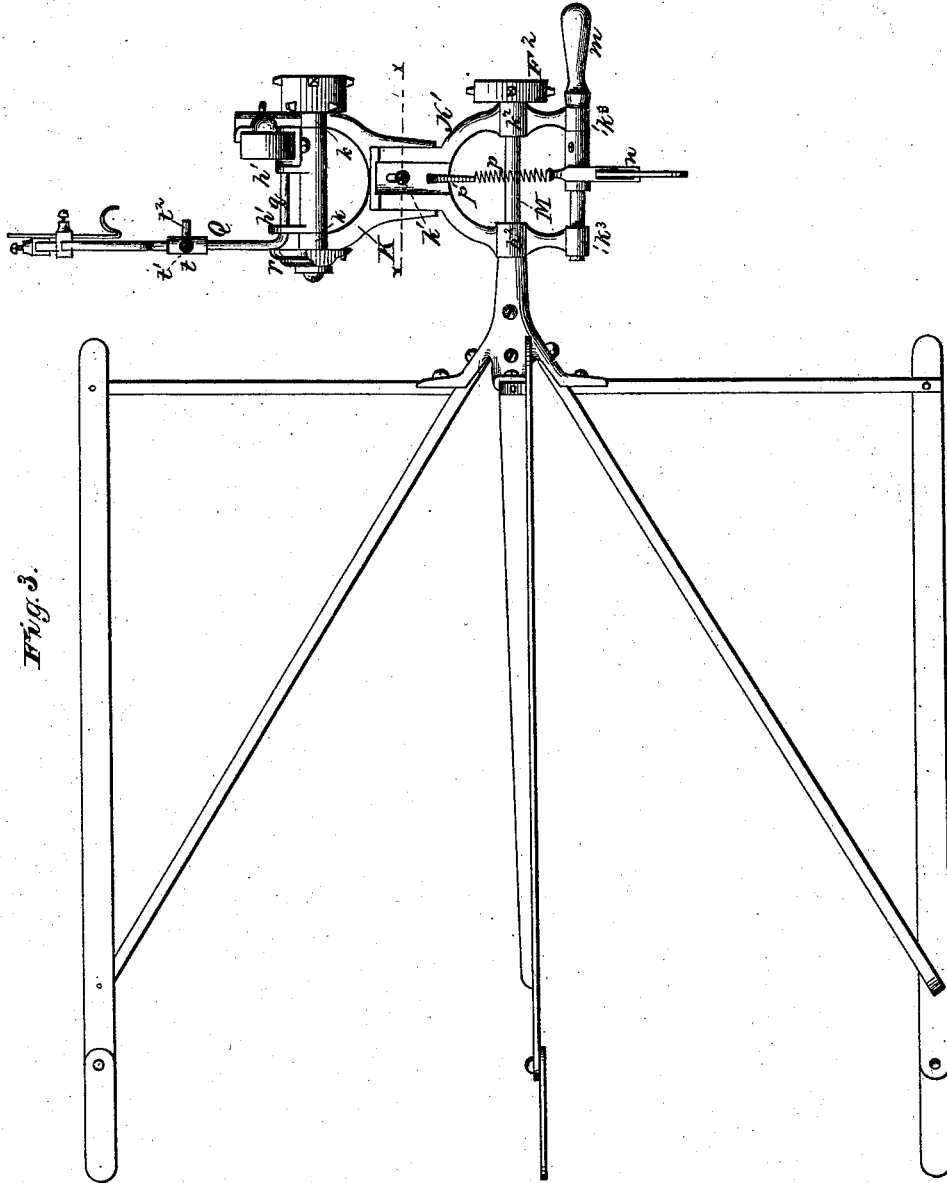

Fig. 3.

WITNESSES  
*Francis L. Curande*  
*Alexander Mahon* By his Attorney

INVENTOR  
*C. Wheeler Jr.*  
*A. M. Smith*

C. WHEELER, Jr.  
Harvester-Droppers.

No. 211,286.

Patented Jan. 7, 1879.

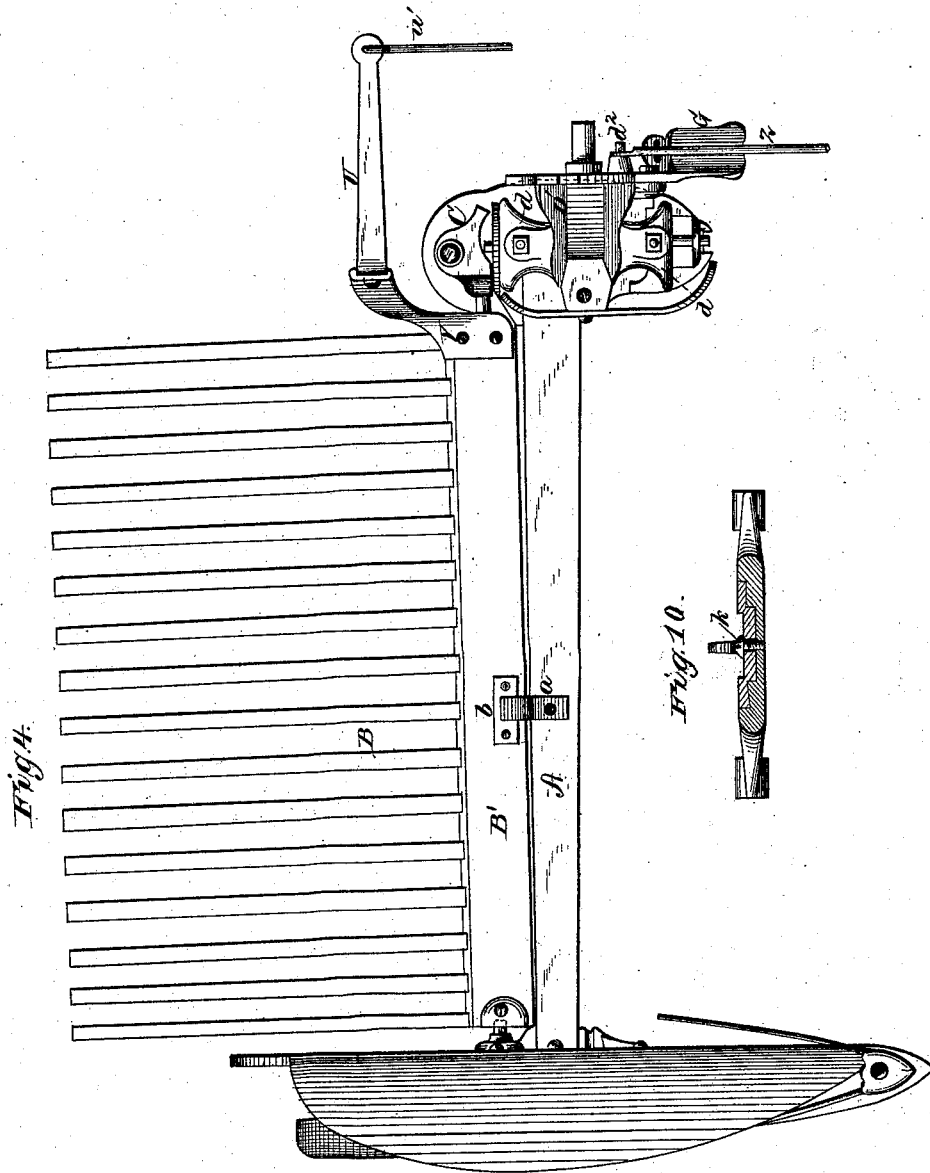

WITNESSES  
*Frank L. Curand*  
*Alexander Mahon*

*By his Attorney*

INVENTOR  
*C. Wheeler, Jr.*  
*A. M. Smith*



# UNITED STATES PATENT OFFICE.

CYRENUS WHEELER, JR., OF AUBURN, NEW YORK.

## IMPROVEMENT IN HARVESTER-DROPPERS.

Specification forming part of Letters Patent No. **211,286**, dated January 7, 1879; application filed November 2, 1878.

*To all whom it may concern:*

Be it known that I, CYRENUS WHEELER, Jr., of Auburn, county of Cayuga, State of New York, have invented certain new and useful Improvements in Dropper Attachments to Harvesters, of which the following is a full, clear, and exact description, reference being had to the accompanying drawings, making part of this specification, in which—

Figure 1 represents a perspective view of a harvesting-machine with my improvements applied. Fig. 2 is a side elevation of the dropper attachment, reel, &c., taken from the side adjacent to the main frame. Fig. 3 is a plan view of the reel-frame and its attachments. Fig. 4 is a plan view of the finger-bar and its attachments, including the dropper, reel stand or bracket, &c. Fig. 5 represents a vertical transverse section through the reel stand and post. Fig. 6 is a side elevation of the reel-post, reel-frame, &c., detached. Fig. 7 represents, in vertical section, the adjustable bearing-bracket through which the reel-frame is pivoted to the reel-post. Figs. 8 and 9 are views of the treadle for operating the dropper and cut-off detached; and Fig. 10 is a section through the jointed reel-frame, taken on line *x x*, Fig. 3.

Similar letters of reference denote the same parts of the machine wherever used.

The invention relates to a novel means for supporting and effecting the adjustment of the reel and for regulating or adjusting the throw or movement of the dropper and cut-off or knuckle-rod, and will be best understood from the following description, with reference to the drawings, in which my improvements are shown applied to and adapted to be used in connection with the machine-truck embraced in Letters Patent granted to me March 19, 1878, No. 201,579, for improvement in harvesters, being intended to take the place of the rake attachment described in said patent; but it will be obvious that my improvements can be applied to machines or machine-trucks having a different construction or organization.

In the accompanying drawings, A represents the finger-bar; B, the slotted dropper pivoted in rear of the bar A in bearing-brackets formed upon or attached to the inner and outer shoes, said parts being of any usual or

preferred construction. The finger-bar, at or about midway of its length, has a metal clip, *a*, bolted to it, its rear projecting end overhanging and resting upon the transverse bar B' of the dropper, or upon a metal wear-plate, *b*, thereon, for preventing the thin metal finger-bar from sagging or injuriously vibrating at that point without interfering with the free rolling movement of the dropper in acting upon the grain.

The inner shoe, C, to which the finger-bar is bolted, has lugs or ears *c*<sup>1</sup> *c*<sup>1</sup> formed upon it, through which pivotal connection is made with the frame of the machine, said ears being made in the form of an inverted U or V, and arranged one in front and the other in rear of the finger-bar.

D is the metal reel-stand, forked at its lower end to stride the finger and sickle bars, and having its arms *d* *d* provided on their lower ends with notches or forks corresponding to the form of the lugs or ears *c*<sup>1</sup>, and fitting snugly thereon.

Eyebolts *d*<sup>1</sup>, passing through the horizontal parts or shoulders of arms *d*, serve to connect the stand D with pins *e*<sup>2</sup>, passing through the lugs *c*<sup>1</sup>, and thus to clamp and hold the stand firmly in place thereon, the pins *e*<sup>2</sup> serving also in the present instance as the pivotal connection between the shoe or cutting apparatus and the machine-frame.

The stand D, above the arms *d*, is curved inward toward the main frame, and has its upper portion, D<sup>1</sup>, flanged to form a socket for the reception of the reel-post E, said socket expanding in width toward its upper end, to permit the reel-post to rock or be adjusted for setting the reel forward or backward, as desired. The lower end of the post E is pivoted in the socket by means of bolt *e*, passing through the stand D and through a sleeve, *d*<sup>2</sup>, formed thereon on the face adjacent to the frame, said sleeve serving as a journal for a double sprocket-wheel, F, through which motion is imparted to the reel, said sprocket-wheel being held in place on its journal-sleeve *d*<sup>2</sup> by the same bolt, *e*, which serves to fasten and pivot the lower end of the reel-post. By this arrangement it will be seen that the reel-post may be adjusted or rocked backward and forward without disturbing its relation to the driving sprocket-

wheel F. The inner vertical wall of the socket for the reel-post is notched or provided with teeth at its upper end, and a spring bolt or latch, *f*, attached to and sliding on the reel-post, (see Figs. 2 and 5,) serves to hold said post at any desired adjustment.

G is a grooved or tubular guide arranged in front of the sprocket-wheel F upon a bracket attached to the reel-stand D, and serving, where the cutting apparatus is hinged, as in the present instance, to guide the slack of the driving-chain with precision to the sprocket-wheel F under all its varying relations to the main frame.

The sprocket-wheel is of the grooved and sprocket form, adapting it to be driven by a straight-link driving-chain from the same sprocket-wheel which, in the machine described in the patent referred to, drives the combined rake and reel.

To the reel-post, at or near its upper end, is secured a bracket, H, (see Fig. 7,) made adjustable up and down, by means of vertical slots and set-screws *h*, for regulating the tension of the reel-driving chain, hereinafter referred to. The bracket H has a horizontal sleeve, H', formed on its forward face, affording a support for a stationary transverse journal, I, secured therein. A reel-frame, made in two parts, K K', has its rear or upper end forked to straddle the sleeve H', the ends of the forked arms being provided with short sleeves *k*, which surround the journal I, permitting the reel-frame K K' to turn or be adjusted upon said journal as a center. This shaft or journal has a double sprocket-wheel, F<sup>1</sup>, mounted upon its inner end and adapted to rotate freely thereon, said wheel receiving motion through a chain, L, from the sprocket-wheel F, above described, at the foot of the reel-post, and, in turn, imparting motion, through a driving-chain, L', to a sprocket-wheel, F<sup>2</sup>, on the reel-shaft. The tension of the driving-chain L is regulated by the vertical adjustment of the bracket H on the reel-post, as described, and provision is made for regulating the tension of the chain L' by forming the reel-frame in two parts, K K', as above described, and making one part adjustable upon or in a socket in the other, and holding them at any desired adjustment by means of a slot and set-screw, as shown at *k*<sup>1</sup>, Figs. 3 and 10. The part K', forming the outer swinging end of the reel-frame, is also forked at its outer end, and the arms are provided, about midway of their length, with sleeve-bearings *k*<sup>2</sup> *k*<sup>2</sup> for the inner end of the overhanging reel-shaft M, to the extreme inner end of which the driving sprocket-wheel F<sup>2</sup>, above referred to, is secured. The fork-arms of part K' of the reel-frame extend forward of or beyond the reel-shaft, and have a rod or handle, *m*, journaled in eye or sleeve bearings *k*<sup>3</sup> in their outer ends. Upon this rod or handle *m* is a latch, *n*, (see Fig. 6,) secured to and rocking with the rod, said latch being provided on its lower side with a loop, *n*<sup>1</sup>, which surrounds and is adapted to slide back

and forth on a brace, O, pivoted at its lower end to the reel-post, as shown. The latch *n*, within the loop *n*<sup>1</sup>, has a pawl or tooth, *n*<sup>2</sup>, formed upon it, which engages with notches *o*' in the brace O, being held therein by means of a spring, *p*, connecting an arm, *n*<sup>3</sup>, on the latch or handle with a lug or ear, *p*<sup>1</sup>, on the reel-frame K', as shown. The lower walls of the notches *o*' are made abrupt, to insure their holding the pawl or latch against the weight of the reel and reel-frame, while the upper walls are inclined outward to the surface of the brace, permitting the spring-latch to ride easily over them in the upward adjustment of the reel and reel-frame.

The handle *m* extends to a point within convenient reach of the driver in his seat on the machine, so that by simply raising the handle, or by rocking it forward and then depressing it, the driver can set the reel at any desired height, the weight of the reel and the tension of the spring *p* acting on the latch or pawl and causing it to engage with the notched brace O, serving to automatically lock the reel at any point where the driver releases the rod or handle *m*.

The sleeve H' has perforated lugs or ears *h*' formed upon its rear face, affording bearings for the pivot *q* of the vibrating cut-off rod or lever Q, formed by bending the upper end of said rod at right angles, as shown in Fig. 3. The pivot thus formed is held in place by a washer, *r*, on the end of the stationary shaft I. The rod Q extends back at *q*<sup>1</sup> a short distance from its pivot *q*, and is thus bent downward, as shown in Figs. 1 and 2, its lower end being squared to receive and permit the vertical adjustment of a square sleeve, *s*, formed on the socket-piece *s*<sup>1</sup>, in which the cut-off Q' is secured.

The adjustment of the cut-off is effected by sliding the socket-piece up or down on the rod Q, a set-screw, *s*<sup>2</sup>, serving to hold it at any desired height. Upon the part *q*<sup>1</sup> of the rod Q is a sleeve or knuckle, *t*, which can be moved nearer to or farther from the pivot for adjusting the throw or movement of the cut-off, being held at any desired adjustment by a set-screw, *t*. (See Fig. 3.) The sleeve or knuckle *t* is provided on one side with a stud or pin, *t*<sup>2</sup>, to which one end of a rod, T, is attached, the lower end of said rod being connected with an upright, U, secured to an elbow-piece, V, which is attached to and extends rearwardly and upwardly from the dropper-bar B'. The upper end of rod T is provided with a number of perforations, adapting it to be set at different heights on the pin *t*<sup>2</sup> for adjusting the angle of relation of the dropper to the ground.

The upper end of the elbow or upright U is bent into a horizontal position, extending behind the machine-frame, and is connected by a rod, *w*<sup>1</sup>, with a treadle, *w*, secured to the driver's foot-board. (See Fig. 1.) The construction of this treadle is shown in Figs. 8 and 9, consisting of the treadle part *w*, provided with the lever-arm *w*<sup>1</sup>, to which the rod *w*<sup>1</sup> is attached, and

hinged to a bracket-piece,  $w^2$ , which is made adjustable, for giving the treadle the proper relation to the dropper by means of a longitudinal slot (shown at  $w^3$ ) and a set-screw passing through said slot into the foot-board.

The treadle is provided on one side with a pin or spur,  $y$ , and a hook,  $y'$ , pivoted to the bracket  $w^2$ , is adapted to be pressed over upon or withdrawn from said pin by the driver's foot for locking the treadle, with the dropper-platform raised to receive the grain or for releasing the same when it is desired to drop the accumulated gavel.

The upward throw of the dropper-platform is limited by a projecting spur or stop,  $D^2$ , formed on the rear face of stand  $D$ , with which the elbow piece or lever  $U$  comes in contact when the dropper is raised to receive the falling grain, and the downward throw of the cut-off  $Q'$  is limited by an adjustable stop,  $q^3$ , attached to the rod  $Q$ , said stop being provided with a forked or  $U$ -shaped foot-piece, which strides and rests upon the connecting-rod  $T$  when the cut-off is lowered to catch the falling grain.

The reel-stand has a stud or pin,  $d^2$ , formed on its inner face above the sheave or sprocket-wheel  $F$ , to which one end of a link or rod,  $z$ , is attached, the opposite end of said rod, in practice, being connected with the tilting-lever described in the patent referred to, as shown in Fig. 1, for rocking the cutting apparatus and setting the points of the fingers higher or lower, as required.

From the foregoing description it will be seen that the driver can raise and lower the reel at pleasure when in his seat and with the machine in motion. He can also tilt or raise the cutting apparatus while the machine is in motion, the same as is done in the self-rake described in the patent referred to. Further, the reel-post can be set forward or back at its

top, and all necessary adjustments of the cut-off rods can be made, this last of course necessitating the stopping of the machine.

Having now described my invention, what I claim as new, and desire to secure by Letters Patent, is—

1. The reel-post pivoted in an upwardly-expanding socket and provided with the spring latch or bolt engaging with a rack on the socket and permitting the adjustment of the reel-post, substantially as described.

2. The reel-stand  $D$ , provided with the sleeve-journal for the driving sprocket-wheel  $F$ , held in place thereon by the bolt which serves as a pivot for the adjustable reel-post, substantially as described.

3. The swinging frame in which the reel is mounted, made in two practically equal overlapping parts, adapted to be adjusted relatively to each other, for moving the reel-shaft toward or away from its driving-shaft.

4. The combination of the pivoted brace with the spring-latch, for holding the reel-frame at any desired adjustment.

5. The rolling latch or pawl, for holding the swinging end of the reel-frame at any desired adjustment.

6. The pivoted reel-frame provided with bearings for the reel-shaft and also for the rolling latch-handle, substantially as described.

7. The adjustable stop on the cut-off arm, for limiting the downward throw of the cut-off.

8. The stop on the reel-standard, for limiting the upward throw of the platform.

9. The clip  $a$ , arranged midway of the finger-bar, and overhanging and resting upon the rocking dropper-platform-bar, for preventing sagging of the finger-bar.

C. WHEELER, JR.

Witnesses:

C. W. UPHAM,  
J. FRANK DAVIS.