

J. R. ABBE.
Ore-Mill.

No. 211,364.

Patented Jan. 14, 1879.

Fig. 1.

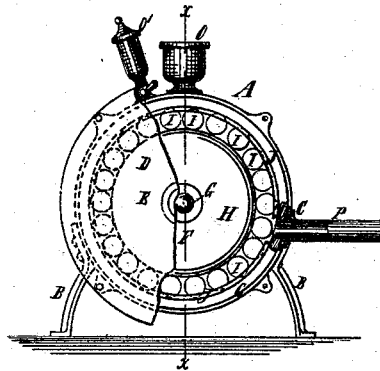
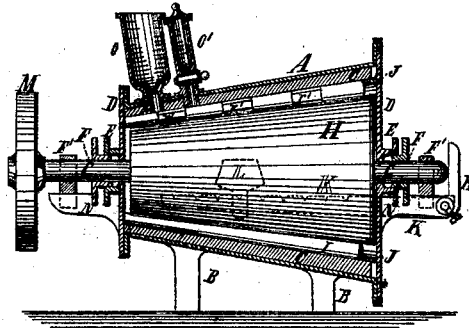

Fig. 2.



Witnesses
John Becker
Chas. Nagree

Inventor
John R. Abbe
by his Attorneys
Brown & Allen

J. R. ABBE.
Ore-Mill.

No. 211,364.

Patented Jan. 14, 1879.

Fig. 3

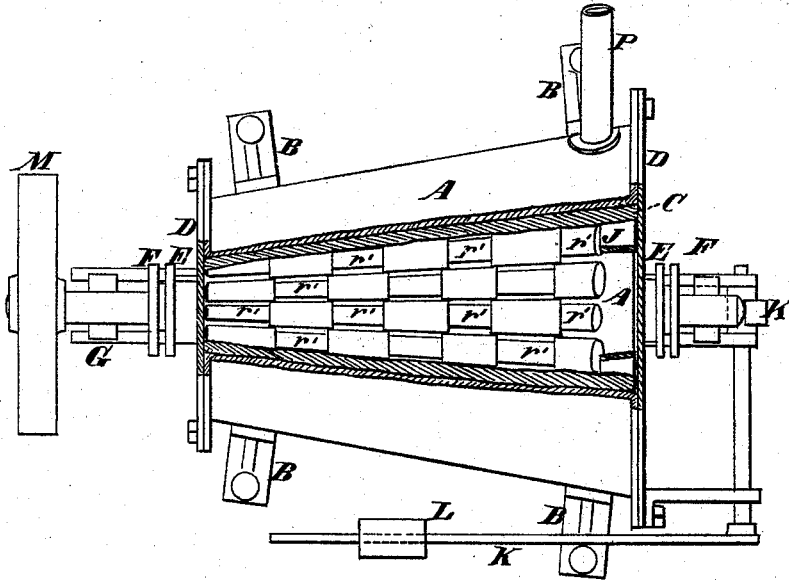

Witnesses

John Becker
Erud. Naumes

Inventor

John R. Abbe
by his Attorneys
Brown & Allen

UNITED STATES PATENT OFFICE.

JOHN R. ABBE, OF SOUTH WINDHAM, CONNECTICUT, ASSIGNOR OF ONE-HALF HIS RIGHT TO CHARLES SMITH, OF SAME PLACE.

IMPROVEMENT IN ORE-MILLS.

Specification forming part of Letters Patent No. 211,364, dated January 14, 1879; application filed April 27, 1878.

To all whom it may concern:

Be it known that I, JOHN R. ABBE, of South Windham, in the county of Windham and State of Connecticut, have invented an Improvement in Amalgamating Ore-Mills; and I do hereby declare that the following is a full, clear, and exact description of the same, reference being had to the accompanying drawing, forming part of this specification.

My invention consists in means for securing a larger percentage of gold or other precious metal than is now realized by the various kinds of apparatus for grinding and amalgamating gold and silver bearing ores hitherto introduced.

Figure 1 in the accompanying drawing is an end view of the apparatus, with a portion broken away to show the interior construction. Fig. 2 is a sectional view of the apparatus, the section being made on the line *xx* in Fig. 1. Fig. 3 is a plan, partly in section, showing a preferable way of constructing the grinding or crushing rollers, hereinafter described.

A is a conical cast-iron case, supported by suitable pedestals or legs B. Said case or shell A is provided with an independent or removable lining, C, having a form corresponding to that of the case. The said lining, when worn, may be replaced without any change or repair of other parts of the machine. The said case or shell A is also provided with heads D, in the centers of which are stuffing boxes or glands E, containing bearings F for a stout shaft, G, upon which a conical cylinder, H, is fitted to revolve within the said case or shell. Between the said cylinder and the said case or shell are fitted conical rollers I, which, when the said cylinder revolves within the said case, are caused, by friction between the said cylinder and case, to revolve also, or to roll between the said cylinder and case. Said rolls are of a number and size to fill the annular space between the said cylinder and case or shell. They are somewhat shorter than the cylinder H, but are kept with their smaller ends flush against the smaller head of the case by an annular ledge, J, formed on the inside of the larger end of the lining C; or a rim of similar form to the said ledge may be cast on the inner face of the larger head of the case or shell;

or a separate detachable ring may be placed within the lining C and the ends of the rollers I. As the rollers I cannot move endwise, it follows that the movement of the cylinder H toward the smaller end of the case will mutually increase the pressure between the case and the rollers and between the cylinder and the rollers. Such a movement or pressure toward the smaller end of the case by the cylinder H is caused by the lever K, which is provided with a weight, L, and is graduated, as indicated in Fig. 2. One end of the lever K bears against the end of the shaft G to produce the end thrust required, which is regulated by setting the weight L in one or other of the notches which indicate the graduations of said lever. The said cylinder is turned by a pulley, M, or other transmitter of motion attached or applied to the shaft G. To relieve the stuffing-box bearings F from undue wear, separate and supplementary detachable bearings F' for the shaft G are supported by brackets N, attached to and projecting from the case A and removable with the said heads.

O is a hopper or funnel, through which crushed or stamped ore and water are introduced into the apparatus, as hereinafter described. O' is a funnel or hopper, through which mercury is introduced for amalgamation with the metal in the ore, as hereinafter set forth. Said hopper or funnel is provided with a cock for regulating the supply of mercury to the apparatus.

Although the conical rollers I will work well with regular surfaces, as shown in Fig. 2, it is preferable to construct them, as shown in Fig. 4, with recesses *r'* cut in them, said recesses being cut in the said rollers at regular or irregular intervals, and preferably in such manner that each recess shall overlie an unrecessed portion of the adjacent roller. The said recesses preferably extend entirely around the rollers. The said recesses act as pockets, wherein the current flowing through the case A is caused to eddy and flow slower in portions than in other portions, and wherein the weightier portions containing the free and amalgamated particles of the metals settle and are either arrested or retarded in their onward passage through the apparatus, the object be-

ing to retain them in contact with mercury till all, or nearly all, the metallic particles as practicable are entrapped. The effect of the well-known riffing-table is by this means secured in the interior of the apparatus. In the lower part of the larger head of the case A is fitted a cock or valve, of suitable construction and capacity to effect the discharge of the sand and mercury, when desired.

The said amalgamating-mill is more especially designed to be used in connection with an amalgamating-separator, to which the fine particles suspended by water in the mill flow out through a pipe, P.

The comminuted ore and water are fed to the mill through the hopper O. Mercury in sufficient quantity is placed in the cup or funnel O', and is allowed to flow down into the interior of the case, where the mingled ore, water, and mercury are brought into very intimate contact during the grinding stage of the process, the grinding being carried to extreme fineness. After the grinding has proceeded to the required degree of fineness, the fine particles are held suspended by the water sufficiently to rise and pass out of the passage P for further treatment, which they will receive in the amalgamating-separator aforementioned, or in any other suitable apparatus.

The grinding-surfaces—that is to say, the cylinder H, the rollers, and the lining—may be made of cast-steel.

I claim—

1. In a grinding and amalgamating apparatus, the combination of the conical or tapered case A, conical or tapered cylinder H, and conical or tapered cylindrical rollers I, interposed between the said cylinder and lining, substantially as and for the purpose specified.

2. The combination of the conical or tapered case A, conical or tapered cylinder H, and conical or tapered rollers I, having therein the recesses *r'*, substantially as and for the purpose set forth.

3. The combination of the heads D D, case A, brackets N, attached to said heads, and the supplementary bearings F', supported by said brackets, for relieving the stuffing boxes and glands E from the weight of the cylinder H and the shaft G, substantially as and for the purpose described.

JOHN R. ABBE.

Witnesses:

JAMES H. JOHNSON,
EUGENE KINNE.