

J. BEAN.
Metallic Wheelbarrow.

No. 211,373.

Patented Jan. 14, 1879.

Fig. 1.

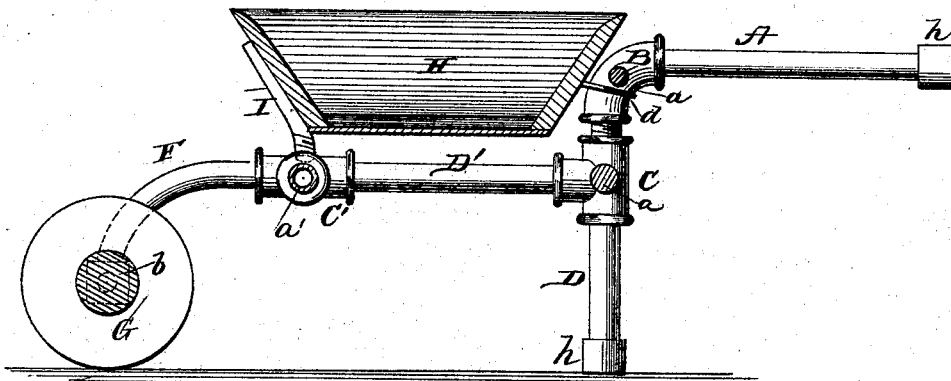
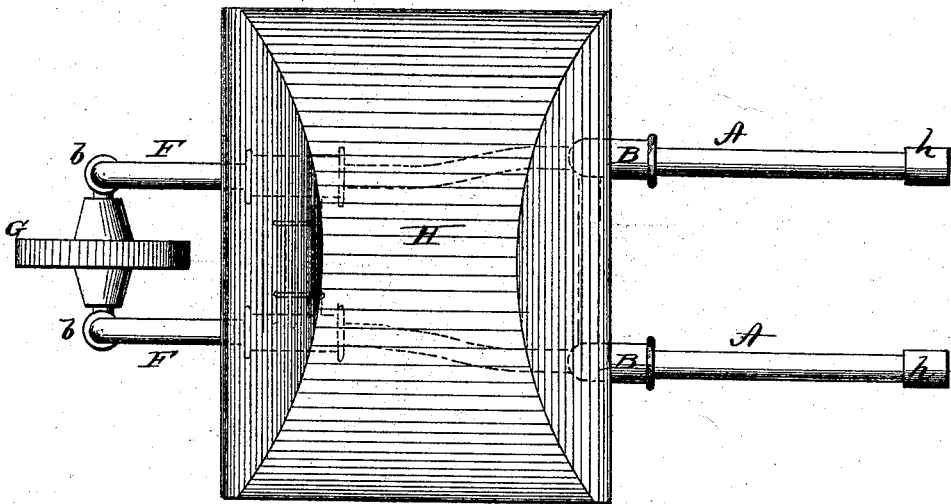

Fig. 2.



WITNESSES

Frank L. Curaud
Halter Mansfield

INVENTOR

By *his* Attorneys

John Bean
Alexander Mason

UNITED STATES PATENT OFFICE.

JOHN BEAN, OF HUDSON, MICHIGAN.

IMPROVEMENT IN METALLIC WHEELBARROWS.

Specification forming part of Letters Patent No. **211,373**, dated January 14, 1879; application filed November 11, 1878.

To all whom it may concern:

Be it known that I, JOHN BEAN, of Hudson, in the State of Michigan, have invented certain new and useful Improvements in Metallic Wheelbarrows; and do hereby declare that the following is a full, clear, and exact description thereof, reference being had to the accompanying drawings, and to the letters of reference marked thereon, making a part of this specification.

The nature of my invention consists in the construction and arrangement of a metallic wheelbarrow, as will be hereinafter more fully set forth.

In order to enable others skilled in the art to which my invention appertains to make and use the same, I will now proceed to describe its construction and operation, referring to the annexed drawing, in which—

Figure 1 is a longitudinal section, and Fig. 2 a plan view, of my metallic wheelbarrow.

The entire frame of my wheelbarrow is made of gas pipe or tubing, making the same strong and durable, and at the same time lighter than if made of solid iron.

A A represent the handles, which are connected, by elbows B B and T-joints C C, with the legs D D. The two elbows B B, as well as the two joints C C, are connected by means of tubular cross bars or ribs *a a*, which may be screwed into or onto the elbows and joints, said parts being provided with holes or lugs for that purpose.

In the T joints or crosses C C are screwed the side carriers D' D', which have at their forward ends other T joints or crosses C' C', connected in the same manner by a cross bar or rib, *a'*.

Into the crosses C' are screwed the curved

or bent arms F F, which are at their lower forward ends provided with caps *b b*, having suitable perforations to receive the journals of the wheel G.

In the upper sides of the crosses C' C' are screwed braces I I, to which the box or tray H is fastened. This box or tray is then, by wires *d*, connected to the elbows B B, as shown.

It will be seen that the box or tray with the forward braces, I, and the rise in the side carriers (crosses C and elbows B) forms a brace to support the center of the hand-bearers A; and the entire structure being of gas pipe or tubes gives elasticity to the barrow when loaded, so as to relieve the hands and arms of the operator.

h h represent caps screwed on the bottom of the legs D and ends of the handles for the purpose of preventing the legs from settling into soft grounds and the hands from slipping off the handles.

Having thus fully described my invention, what I claim as new, and desire to secure by Letters Patent, is—

1. The combination of the box H, forward braces, I I, and the tubular side carriers D' D', with the rear rise and brace, B C, as and for the purposes herein set forth.

2. The combination of the handles A, elbows B, crosses C C', legs D, side carriers D', arms F, and wheel G, substantially as herein set forth.

In testimony that I claim the foregoing I have hereunto set my hand.

JOHN BEAN.

Witnesses:

JAMES B. THORN,
H. AUBREY TOULMIN.