

H. WILLARD & A. M. CHENEY.
Mechanical Telephone.

No. 211,486.

Patented Jan. 21, 1879.

Fig. 1.

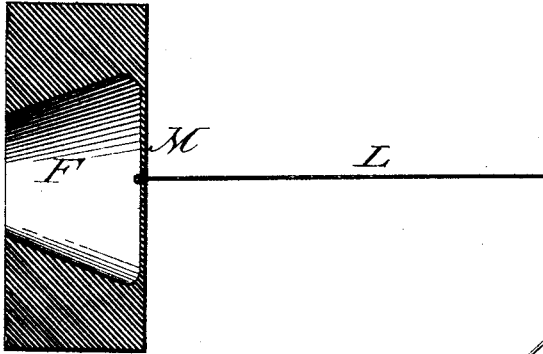
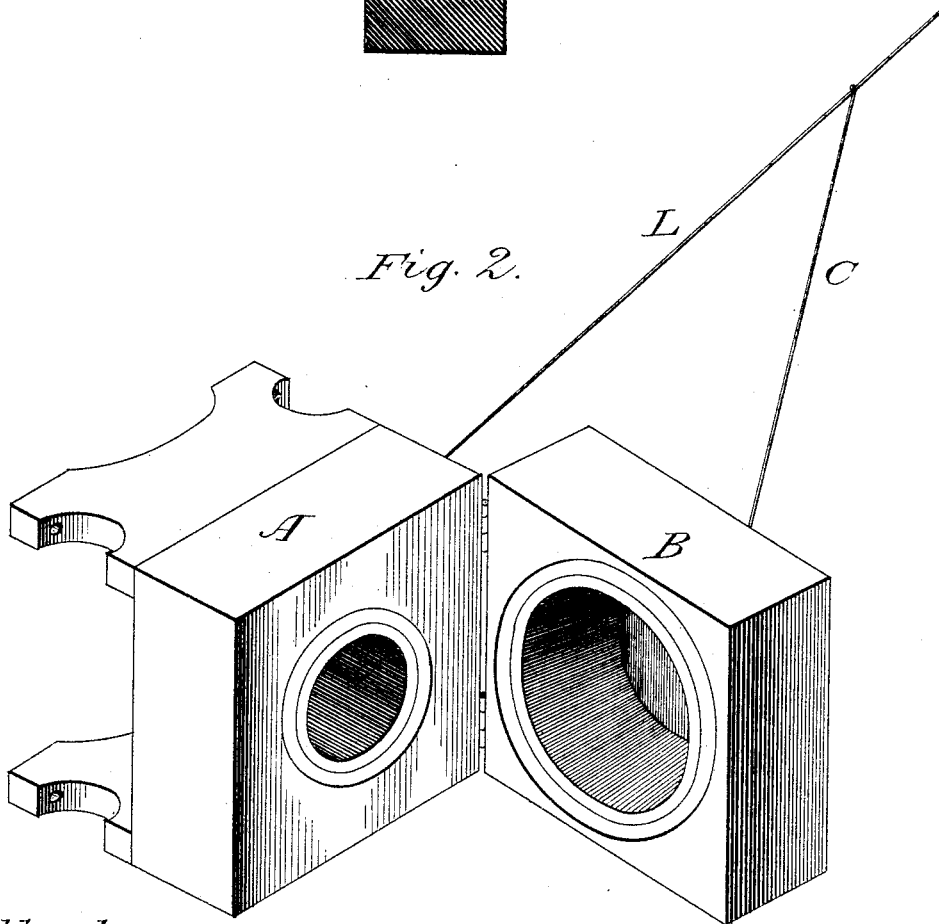

Fig. 2.



Attest;

*Phil. D. Passason
George H. Rowley*

Inventors.

*Henderson Willard
Alonzo M. Cheney*

UNITED STATES PATENT OFFICE

HENDERSON WILLARD AND ALONZO M. CHENEY, OF CHARLOTTE, MICH.

IMPROVEMENT IN MECHANICAL TELEPHONES.

Specification forming part of Letters Patent No. **211,486**, dated January 21, 1879; application filed October 16, 1878.

To all whom it may concern:

Be it known that we, HENDERSON WILLARD and ALONZO M. CHENEY, both of Charlotte, Eaton county, in the State of Michigan, have invented a certain new and useful Improvement in Acoustic or Mechanical Telephones, of which the following is a full and sufficient specification, reference being had to the accompanying drawings and letters of reference marked thereon.

Like letters in the different figures mean the same thing.

The trouble with acoustic telephones heretofore has been that the reverberations drown the articulate sounds, or render them too indistinct for practical use.

We have overcome this difficulty by constructing our telephone of solid wood, using no other vibrating material.

All are more or less familiar with the peculiar acoustic properties of wood. The ticking of a watch or the articulate sounds of the voice may be distinctly heard throughout the longest stick of timber.

One mode of carrying out our invention is to turn a cup or funnel in the side or end of a solid block of wood, in such a manner that the bottom of the cup shall form the diaphragm of the instrument; or the cup may be turned entirely through the block, and the diaphragm of wood glued onto the solid walls of the cup. (See Figure 1, in which F is the funnel or cup, M is the diaphragm, and L is the line or wire connecting it with a similar instrument at a distant office.) The block is ten inches square and two inches thick, more or less. The cup-bottom is four inches in diameter, and the diaphragm is from one-sixteenth to one-fourth of an inch in thickness, according to the distance between offices connected by the line. If the distance is short, the thicker

one is better; but, for the sake of most perfect results, we hinge two instruments together, one with thick diaphragm for receiver and the other with thin diaphragm for speaker, and in such a manner that the operator can speak in one and receive in the other without turning, as shown in Fig. 2, in which A is the receiver, and B is the speaker, and C is a short line connecting speaker B with main line L, which is anchored fast to the diaphragm of receiver A.

After speaking in B the operator swings it back, which slackens its line C, and the answer comes directly to A, and is received privately; but if speaker B is left in full tension the message can be heard by many.

Any kind of wood is suitable for these instruments; but ash or walnut is preferable, and they can be made externally round or angular and ornamented to suit taste.

We do not claim, broadly, the use of a wooden box as a sounder or receiver, as we know that cigar-boxes have long been used for the same purpose.

What we do claim as new, and wish to secure by Letters Patent, is—

1. An acoustic-telephone instrument consisting of a cup or funnel in the end or side of a solid block of wood, so that the bottom of the cup shall form the transmitting or receiving diaphragm, substantially as set forth.

2. The combination of the transmitting and receiving diaphragms and their frames, hinged together at the sides, as shown, so that they may be turned in position to receive and transmit sounds to the operator at the same time.

HENDERSON WILLARD.
ALONZO M. CHENEY.

Witnesses:

ELISHA STEWART,
J. M. HASLETT.