

G. H. DOANE.
Middlings-Separator.

No. 211,501.

Patented Jan. 21, 1879.

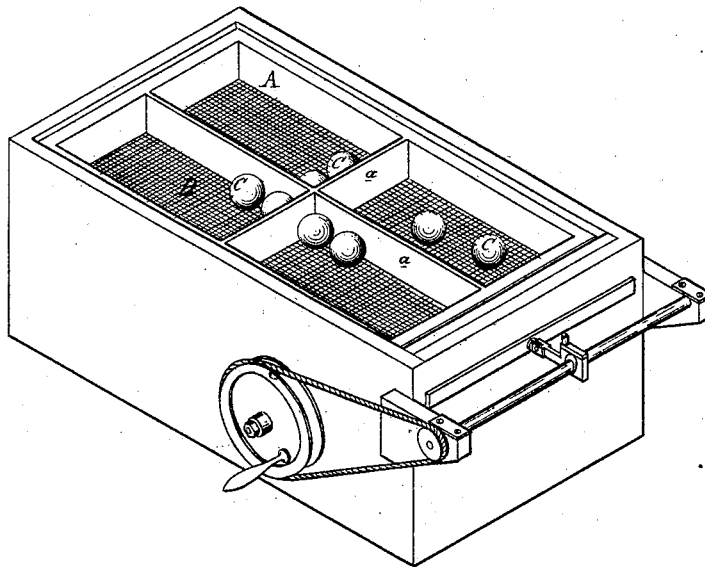

Attest:
J. Bartzel
W. Sprague

Inventor:
Geo. H. Doane
By Atty
Thos. C. Sprague

UNITED STATES PATENT OFFICE.

GEORGE H. DOANE, OF DETROIT, MICHIGAN.

IMPROVEMENT IN MIDLINGS-SEPARATORS.

Specification forming part of Letters Patent No. **211,501**, dated January 21, 1879; application filed September 18, 1878.

To all whom it may concern:

Be it known that I, GEORGE H. DOANE, of the city of Detroit, in the county of Wayne and State of Michigan, have invented an Improvement in Flour-Bolting Machines and Middlings-Separators, of which the following is a specification:

The nature of my invention relates to a new and useful improvement in keeping the bolting-cloths of vibrating separators from clogging. In the employment of devices for this purpose it has been found necessary to use various and sundry devices, like mechanically-moving brushes, traveling or stationary air-blasts, knockers, and other devices, all of which are more or less expensive and liable to derangement in their operation.

The object of my invention is to provide a very economical method of accomplishing this result, and one that will not be liable to get out of order.

The figure is a perspective view of a vibrating frame carrying a bolting-cloth within a middlings-purifier case, with the cover thereof removed.

In the accompanying drawing, which forms a part of this specification, A represents the screen-frame provided with its longitudinal and lateral stiffening-bar *a*, and having secured to its under side the bolting-cloth B. C represents balls, made of any elastic material. A number of these balls are placed upon the cloth within each of the compartments made by the frame-braces, the latter standing sufficiently above the cloth to allow the ground chop to pass under them.

A vibratory or reciprocating motion is given to the screen-frame by any of the devices in ordinary use.

In practice the elasticity of the bolting-cloth is very largely destroyed by the weight of chop or meal passing over it, and the meshes thereof become clogged by the fine flour passing through them. The balls being in place, and the screen, as is usual, being slightly inclined from head to foot, and being given a rapid vibratory or reciprocating mo-

tion to carry the chop over the screen, the balls are caused to dance by their elasticity, and pass down from the higher to the lower point in each compartment until they strike the obstruction made by the lateral stiffening brace or braces and the end of the frame, when the impact against the same will quickly return the balls to the starting-point. Such dancing passage of the ball and forcible returning, as described, operates to gently clear the meshes from the clogging flour.

I am aware of the patent to E. H. Vittecoq, January 3, 1865, and to Burdick and Fuller, April 7, 1874.

I am also aware that machines are in use wherein grains of corn, wheat, or pease are employed for a like purpose, and wherein such grains pass over the tail of the machine's with the chop or meal onto a screen, where they are separated from the meal and delivered to an elevator to be returned to the starting-point, and do not claim any part of the invention described in said Letters Patent or employed in the machines referred to.

Non-elastic balls may be employed, provided the requisite elasticity is obtained by lining the inner side of the frame and braces with any elastic material, by means of which the balls may be returned to the head of the machine or compartment, it being the spirit of my invention to employ the necessary elasticity either in the balls or in their surroundings to accomplish the desired purpose.

What I claim as my invention is—

1. As a means of cleansing or freeing the meshes of bolting-screens, loose balls passed over the upper surface thereof and returned to their starting-point by an elastic impact, substantially as described.

2. In combination with a reciprocating bolting-screen of a middlings-separator, balls made of any suitable elastic material, for the purposes set forth.

GEORGE H. DOANE.

Witnesses:

H. S. SPRAGUE,
A. BARTHEL.