

G. H. HAYDEN.
Cigarette-Machine.

No. 211,509.

Patented Jan. 21, 1879.

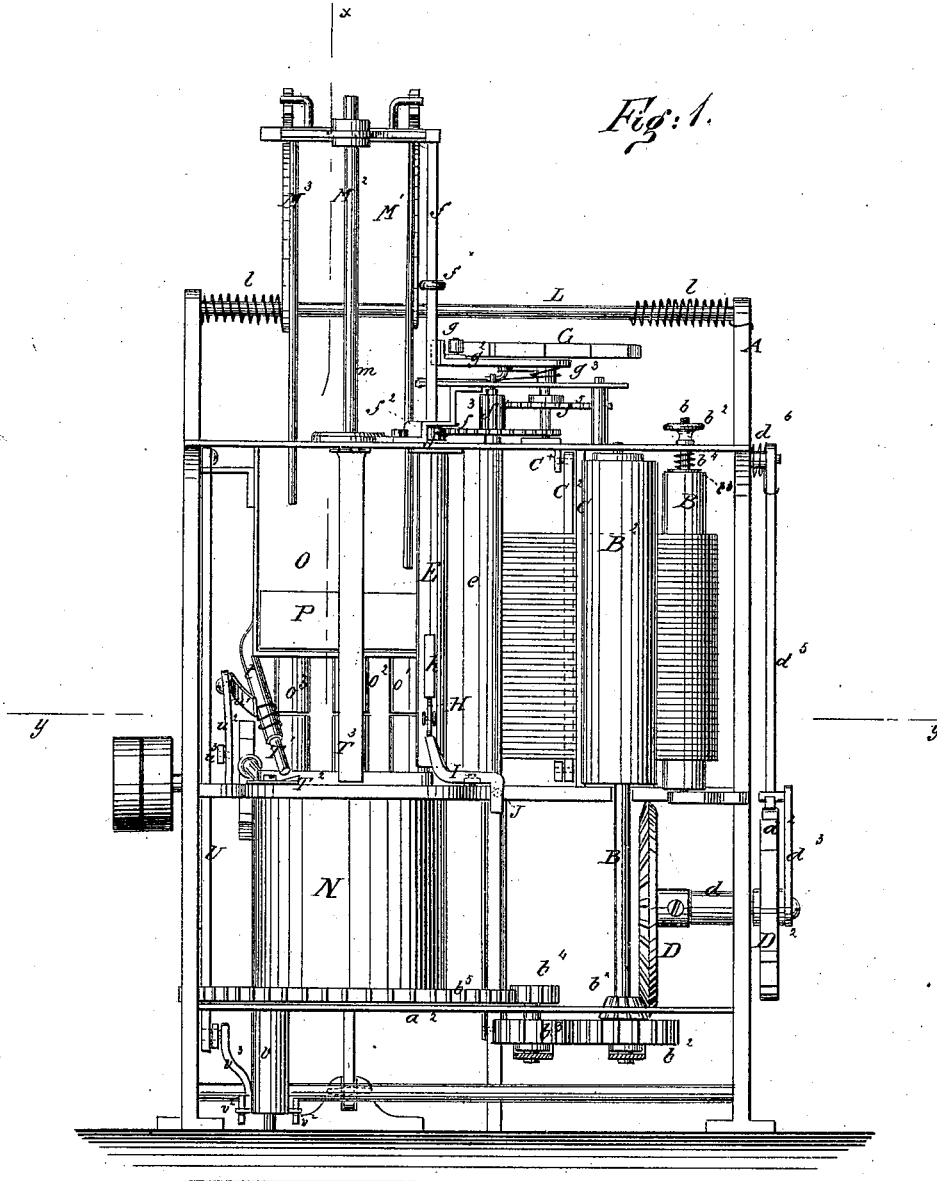

WITNESSES:

Chas. Notta
C. Sedgwick

INVENTOR:

G. H. Hayden
BY *Merritt*

ATTORNEYS.

G. H. HAYDEN.
Cigarette-Machine.
No. 211,509. Patented Jan. 21, 1879.

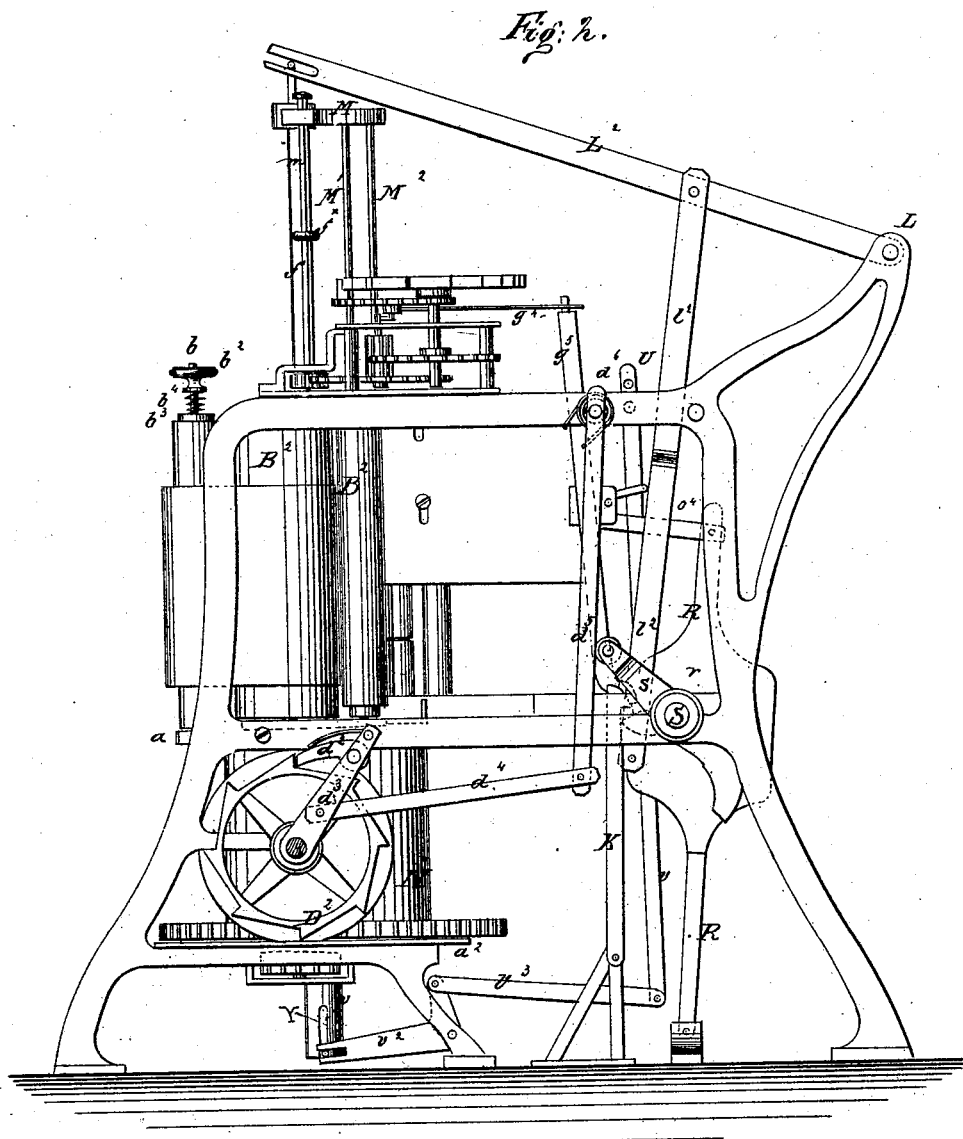

WITNESSES:

Chas. Nida
C. Sedgwick

INVENTOR:

G. H. Hayden
BY *Munroe*

ATTORNEYS.

G. H. HAYDEN.
Cigarette-Machine.

No. 211,509.

Patented Jan. 21, 1879.

Fig. 3

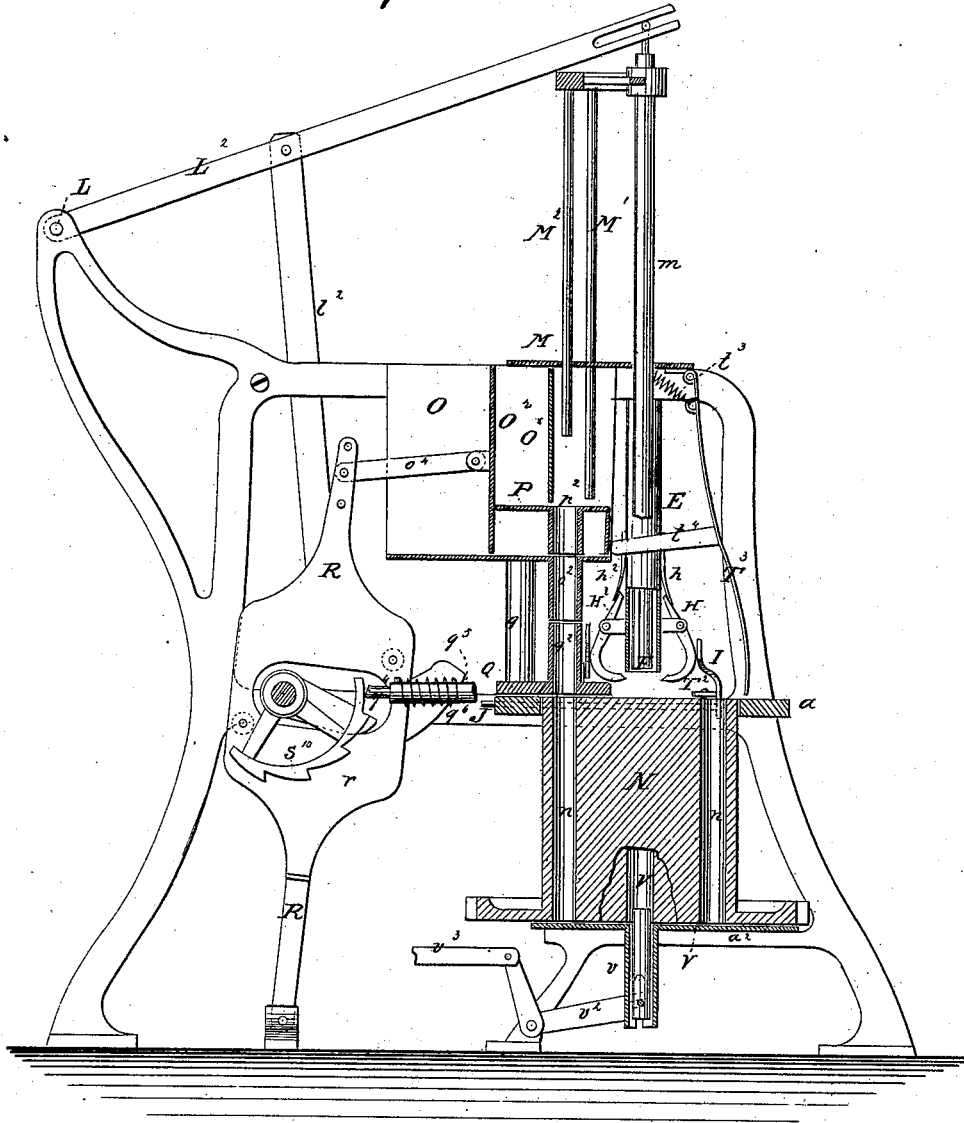

WITNESSES:

Chas. Niota
C. Sedgwick

INVENTOR:

G. H. Hayden
BY *Murphy*

ATTORNEYS.

G. H. HAYDEN. Cigarette-Machine.

No. 211,509.

Patented Jan. 21, 1879.

Fig. 4.

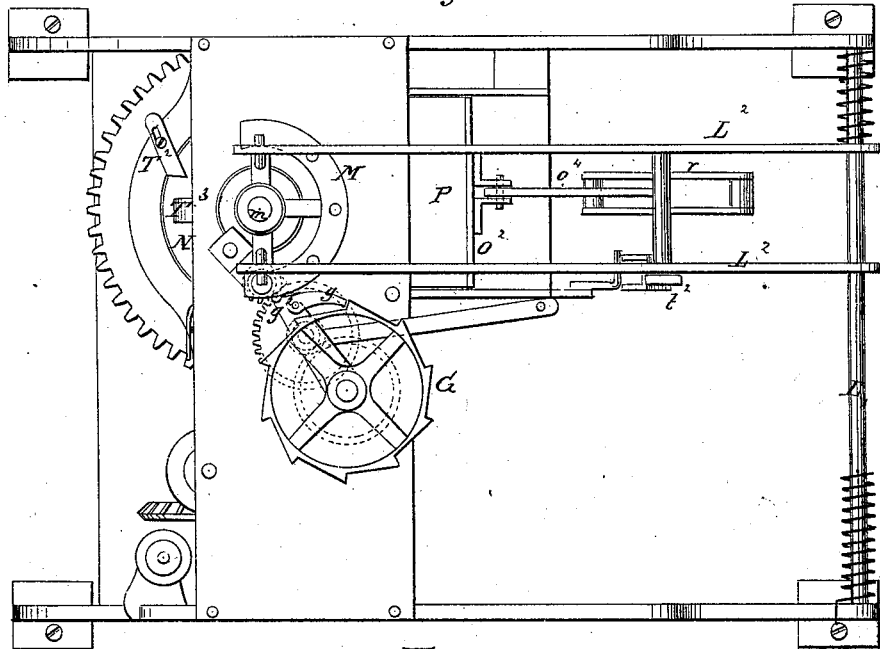
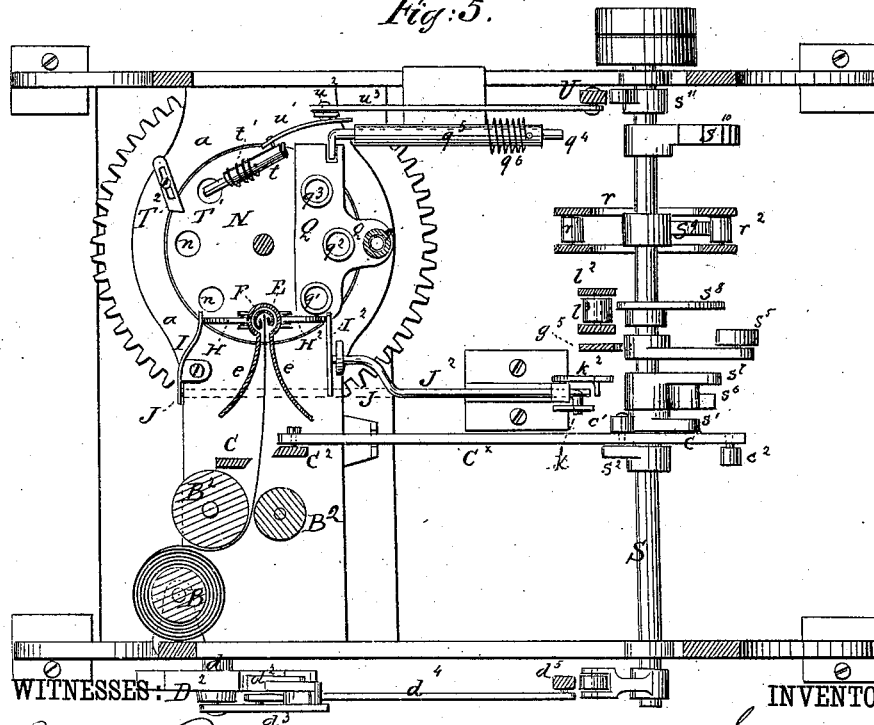

Fig. 5.



WITNESSES: *d¹*, *d²*, *d³*, *d⁴*

Chas. Mag.
C. Sedgwick

INVENTOR:

G. H. Hayden
BY *Minnetonka*

ATTORNEYS.

UNITED STATES PATENT OFFICE.

GEORGE H. HAYDEN, OF BOSTON, MASSACHUSETTS.

IMPROVEMENT IN CIGARETTE-MACHINES.

Specification forming part of Letters Patent No. **211,509**, dated January 21, 1879; application filed June 15, 1878.

To all whom it may concern:

Be it known that I, GEORGE HENRY HAYDEN, of Boston, in the county of Suffolk and State of Massachusetts, have invented new and useful Improvements in Machines for Making Cigarettes, of which the following is a specification:

My invention relates to an apparatus in which the paper tube is formed, the tobacco packed therein, the ends of the tube turned down, and the cigarette completely finished by one passage through the machine.

The invention will first be described in connection with the drawings, and then pointed out in the claims.

In the accompanying drawings, Figure 1 represents a front view of a machine constructed according to my invention. Fig. 2 is a view of one side of the machine. Fig. 3 is a vertical sectional view taken in the line $x x$ of Fig. 1. Fig. 4 is a top view of the machine. Fig. 5 is a horizontal section taken in the line $y y$ of Fig. 1.

Similar letters of reference indicate corresponding parts.

The working parts of the apparatus are carried by a frame, A, which may rest upon a bench, table, or other suitable support. In the upper portion of the frame is journaled a vertical roller, B, on which is wound the paper from which the tubes are made.

The roller B turns loosely on a shaft, b , the upper end of which is screw-threaded, and carries a thumb-nut, b^2 . On the upper end of the roller rests a washer, b^3 , and between this washer and the thumb-nut is a spring, b^4 . By tightening or loosening the thumb-nut the spring may be compressed or expanded, so as to increase or diminish the friction of the washer on the end of the roller, and by this means the roller is caused to rotate more or less freely, as may be desired.

The working parts of the apparatus receive their motion primarily from the main shaft S, which is journaled in the rear portion of the frame A, as shown in the several figures.

Near the paper-roller B are two upright feed-rollers, $B^2 B^2$, which may be faced with rubber or other soft or elastic material. One of these rollers is fast on the upper portion of

a vertical shaft, B^x , which will be hereinafter more particularly referred to, and the second roller is driven by friction from the first one. The paper is fed from the roller B by the two rollers $B^2 B^2$ to a device which forms it into a tube for the reception of the tobacco.

The feed-rollers B^2 have an intermittent rotary motion imparted to them through a bevel-pinion, b^x , on the lower portion of the shaft B^x , to which shaft one of said rollers is fixed, as before stated.

The pinion b^x is driven by a bevel-gear wheel, D, at one end of a shaft, d , journaled in the lower part of the frame A. The other end of the shaft d carries a ratchet-wheel, D^2 , driven by a spring-pawl, d^2 , carried by an arm, d^3 , having its lower end working loosely on the end of the shaft d . The arm d^3 is connected by a rod, d^4 , with a lever, d^5 , pivoted to the frame A, and provided with a spring, d^6 , for drawing it in a direction toward the rear of the frame.

The main shaft S, before referred to, carries a cam or other suitable device for operating this lever, so as to impart motion to the ratchet through the pawl. As here shown, this device consists of an arm, s , with a friction-roller at its end. At every revolution of the main shaft S the arm s forces the lever d^5 toward the front of the machine, so as to cause the pawl d^2 to turn the ratchet-wheel D^2 a distance equal to the length of one tooth. As soon as the arm s has passed the lever d^5 said lever is retracted by the spring d^6 .

The teeth of the gear b^x , bevel-wheel D, and ratchet-wheel D^2 are of such numbers and arrangement with relation to each other that the movement of the ratchet-wheel a distance of one tooth causes the feed-rollers to feed a quantity of paper just sufficient for the forming of one tube.

In its passage to the tube-former the paper passes between shears, which cut it in pieces of the proper size for the tube. (See Fig. 5.) The shears consist of a stationary blade, C, and a movable blade, C^2 , arranged so that their cutting-edges meet each other at a line directly between the feed-rollers and the tube-former. The movable blade C^2 has its upper end pivoted in the upper portion of the frame

of the machine, and its lower end pivoted to one end of a rod, C^x , at the other end of which is a yoke, e , provided with two friction-rollers, $c^1 c^2$. The main driving-shaft S passes through the yoke e , and carries two cams, $s^1 s^2$, for engagement with the rollers $c^1 c^2$ on the yoke. The cam s^1 strikes the roller c^1 and forces the blade c^2 in one direction to cut the paper, and the cam s^2 strikes the roller c^2 and separates the blades, to allow the paper to continue its passage between them.

The tube-former works in a cylindrical casing, E , having both ends open, and having the upper end secured to the upper part of the frame A . In the casing E , on the side toward the feed-rollers, is a slot or opening extending the entire length or height of the cylinder, and from this slot extend two curved and outwardly-flaring guide flanges or wings, $e e$.

The casing and flanges may be in three separate pieces, or they may be made in the manner shown in Fig. 5—that is to say, by bending a piece of sheet metal midway of its length in an inward direction to form the cylinder, and then bending the ends of the metal outward to form the flanges or wings, with a space for the passage of the paper between the two angles where the wings are bent outward from the cylinder.

As the paper is fed by the feed-rollers B^2 it is guided by the wings $e e$ and passes through the slot or opening into the cylinder E , where it is engaged by the tube-former and rolled into a tube.

The tube-former F is made of a piece of sheet metal bent inward, as though to form a cylinder, until its edges meet, and then turn farther inward toward the interior surface of the metal, with a space between them for the reception of the end of the paper. The upper end of the former F is attached to a rod, f , which is angular in its cross-section, or has a rib or feather thereon, and is free to move up and down through a pinion, f^2 , (see particularly Figs. 1 and 2,) having its bearings in the top of the frame A . The pinion f^2 is driven by a gear-wheel, f^3 , which receives an intermittent rotary motion, through a pinion, f^4 , and gear-wheel f^5 , from a ratchet-wheel, G , actuated by a spring-pawl, g , carried by an arm, g^2 , which works loosely on the shaft which carries said ratchet-wheel and said gear-wheel f^5 . The arm g^2 is provided with a spring, g^3 , for drawing it in a direction toward the front of the machine. The arm g^2 is connected by a rod, g^4 , with a lever, g^5 , which is pivoted about midway of its length to a portion of the frame A . On the main shaft S is a cam or an arm, s^5 , with a friction-roller at its end, which engages with the lower end of the lever g^5 , so as to pull the arm g^2 toward the rear of the machine and cause the pawl g to turn the ratchet-wheel G a distance of one tooth. The teeth of this ratchet and of the gearing between it and the rod f are of such number and arrangement with relation to each other that the movement of the ratchet-

wheel one tooth gives two revolutions to the rod f and tube-former F .

The edge of the paper being engaged between the turned-in edges of the former F , the revolution of said former rolls the paper into a cylindrical tube, which, when filled with tobacco, constitutes the wrapper of the cigarette.

The lower bearings of the rollers $B^2 B^2$, and of some other parts not yet described, are carried by a plate, a , which is located about midway of the height of the frame A , and forms a part thereof. As the paper is fed along by the rollers B^2 its lower edge runs on this plate a ; but the cylinder E and the former F , when at work, do not extend entirely down to said plate, and the consequence is that when the rolling of the paper by the former is completed the lower end of the finished tube extends below the bottom of the cylinder.

By this means provision is made for heading the lower end of the paper tube, which is done in the following manner:

On one side of the cylinder E is pivoted a lever, H , the lower end of which is bent or curved inward toward the center of the bottom of said cylinder, and the upper end of which is pressed by a spring, h , against the exterior surface of the cylinder, so as to hold the curved or hooked lower end clear of the bottom, as shown in Fig. 3. On the opposite side of the cylinder is pivoted a similar lever, H^2 , provided with a similar spring, h^2 .

On the plate a is pivoted a lever, I , (see Figs. 1, 3, and 5,) which oscillates in a horizontal plane. One arm of this lever presses against the curved lower arm of the lever H , and its other arm is pressed against by one end of a sliding rod, J , the other end of which is connected with the upper end of a lever, k , having its lower end pivoted in the lower portion of the frame A .

Another sliding rod, J^2 , works in bearings near the rod J , and carries at one end a plate or arm, I^2 , which presses against the curved lower arm of the lever H^2 , while the other end of said rod J^2 is connected with the upper end of a lever, k^2 , arranged by the side of and in a similar manner to the lever k .

On the main shaft S are two cams, $s^6 s^7$, which engage with the upper portions of the levers $k k^2$. As the shaft S revolves the cams $s^6 s^7$ bear against these levers and cause them to slide the rods $J J^2$ in their bearings and through the lever I and plate or arm I^2 , to force the curved lower ends of the levers $H H^2$ inward toward the center of the bottom of the cylinder E . First, the cam s^7 bears against the lever k^2 , so as to force the curved or hooked end of the lever H^2 inward to engage with one side of the projecting lower portion of the paper tube, and bend or fold it inward. Then, as the revolution of the shaft S continues, the cam s^6 bears against the lever k so as to force the hooked end of the lever H inward to engage with the other side of the paper, and

fold it so as to lap over the portion previously turned inward by the hooked lever H². This closes the lower end of the tube, and forms the first head thereof, and the tube is then ready for the filling and finishing processes, the details of which are as follows:

In the rear upper portion of the frame A is journaled a rock-shaft, L, to which is rigidly attached one end of a beam, L², extending toward the front of the machine. The beam may consist of a single piece, or of two pieces, as shown. The shaft L is provided with springs *ll*, which have a tendency to turn it in a direction to raise the beam L², and it may, in addition, be provided with a counterbalance-weight for the same purpose.

The front end of the beam L² connects with a cross-head, M, which slides on a guide-rod, *m*, projecting above the top of the frame A, and secured to the upper and lower plates of said frame.

To the cross-head M are attached three rods, M¹ M² M³, of three different lengths, extending downward and serving as plungers, for the purpose hereinafter described. To the cross-head M is also connected the upper portion of the rod *f*, which carries the tube-former F. Said rod passes through a hole in said cross-head, and it is provided with an adjustable collar, *f*^x, against which the cross-head bears as it descends, and a flattened head at the upper end, against which the cross-head bears as it rises.

To the beam L², at a suitable point between the shaft L and the cross-head M, is connected the upper end of a pitman, *l*², the lower end of which is provided with a yoke carrying a friction-roller, *l*³. The main shaft S carries a cam, *s*⁸, which engages with said yoke and friction-roller to pull the beam downward. As soon as said cam has passed the roller *l*³ the beam is raised by the action of the springs *l* and the counter-balance, before referred to.

The vertical rod *m* forms the axis of rotation for a revolving cylinder, N, which receives motion from the feed-roller shaft B^x through a gear-wheel, *b*², on the lower end of said shaft, engaging with a pinion, *b*³, on a shaft with another pinion, *b*⁴, which meshes into a gear-wheel, *b*⁵, attached to or formed on the lower end of the cylinder N. In this revolving cylinder are a number of cylindrical chambers, *n*, open at both ends, and of the exact size required for the finished cigarette.

Above the cylinder N is the tobacco-box O, the bottom of which communicates with three short tubes, *o*¹ *o*² *o*³, located so as to conduct the tobacco to the chambers *n* of the cylinder as said chambers are successively brought under said tubes by the rotation of the cylinder.

In the tobacco-box works a sliding carrier, P, containing three chambers, *p*², corresponding in size with the short tubes just described, and so arranged with relation thereto that when the carriage is moved forward the three chambers will be immediately over the three tubes and over three of the chambers *n* of the

cylinder N. Each of the chambers of the carrier is of only one-third the capacity of one of the chambers of the cylinder, so that each chamber *n* receives the tobacco in the paper tube carried by it, in three installments, from the three chambers *p*² successively.

The three plunger-rods M¹ M² M³, before described, are located immediately over the three chambers of the carrier. Immediately under the three short tubes of the tobacco-box is a shaking device, consisting of a plate, Q, arranged to oscillate in a horizontal plane on a pivot, and provided with three short tubes, *q*¹ *q*² *q*³, communicating with the tubes of the box O and with the chambers of the cylinder N.

The rear side or end wall of the tobacco-box is movable back and forth, and consists of a board or plate, O², and the rear edge or end of the sliding carrier P is attached to said movable wall.

For imparting a reciprocating motion to said parts, the board or plate O² is connected by a pitman, *o*⁴, with a lever, R, having its lower end pivoted near the bottom of the frame of the machine, and having in its upper portion a yoke, *r*, provided with two friction-rollers, *r*¹ *r*². The main shaft S passes through the yoke *r*, and carries a cam, *s*⁹, for alternate engagement with the rollers *r*¹ *r*², so as to move the carrier P backward and rearward at every revolution of the shaft S.

In the tobacco-box is a vertical partition, O^x, which extends downward to the top of the carrier P, and said carrier passes under said partition as it reciprocates, and is prevented thereby from carrying with it more than the three chambers full of tobacco.

For oscillating the shaking device, the plate Q is connected to one end of a rod, *q*⁴, which works in a sleeve, *q*⁵, and has its other end arranged for engagement with a ratchet-cam, *s*¹⁰, carried by the main shaft S. The sleeve *q*⁵ is provided with a spring, *q*⁶, which has a tendency to pull it rearward, while the faces of the cam *s*¹⁰ push it forward as they respectively engage with it.

To the front portion of the tobacco-box is attached a sleeve, *t*, inclined at an angle of about forty-five degrees, more or less. In this sleeve works a pin or rod, T¹, provided with a spring, *t*¹, for holding it in place and pressing it upward. The rear or upper end of the pin T¹ is connected, by a link, *u*¹, short lever *u*², and connecting-rod *u*³, with a lever, U, the upper end of which is pivoted in the upper part of the frame A. The main shaft S carries a cam, *s*¹¹, for engagement with this lever.

At every revolution of the shaft the cam *s*¹¹ presses the lever U forward so as to force the pin T¹ downward, and as soon as the cam *s*¹¹ has passed the lever U the spring *t*¹ returns the parts to their former positions.

The pin T¹ constitutes the first of the devices for "heading" the upper end of the finished cigarette.

The second device consists of a plate, T², secured to the plate *a* of the frame A by a screw

or bolt, so that one end will project over the top of the revolving cylinder N, and over a portion of each chamber *n*, as it passes around with the cylinder, said projecting portion being bent upward toward the pin T¹.

The third device consists of a bar, T³, having its upper end hinged to the upper portion of the frame, so that it may swing outward, and provided with a spring, t³, for pulling it inward. Its lower end is slightly bent or curved inward toward the vertical shaft *m*, and it is provided about midway of its length with an arm, t⁴, which bears against the front of the carrier P, and is held against it by the spring t³.

The bottom of the cylinder N rests upon a plate, a², which forms part of the frame A. In this plate are two holes, of a diameter equal to or slightly greater than the chambers *n*. One of these holes is directly in line with the tube-former F, and the other is diametrically opposite thereto, in the circle described by the cylinder N. In the last-mentioned hole a plug passes, for engagement with the chambers *n* successively. This plug V works in a sleeve, *v*, attached to the plate a², and is provided with a spring for holding it upward. Its lower end is connected by an elbow-lever, v², and connecting-rod v³ with the lower end of the lever U, before described. As the cam s'' bears against the lever U the plug V is drawn downward; and when said lever is released by said cam the plug is forced upward by its spring so as to enter the bottom of one of the chambers *n* as they successively reach it.

The motions and speed of the various parts with relation to each other and to the main driving-shaft are governed by the number of chambers in the cylinder N. The number here shown is eight, and the parts are geared and arranged to perform the proper motions in the proper times to correspond therewith.

The process of making the cigarette is as follows: The paper passes from the roller B between the feed-rollers B², the shear-blades C C², and guide-wings *e e* to the tube-former F, where it is rolled into a tube to form the wrapper. The lower end is then headed by the levers H¹ H². The tube-former F is then depressed by the beam L², and deposits the tube in a chamber, *n*, and immediately rises again to form another tube. As the cylinder revolves, the tube is carried successively under the three tubes o¹ o² o³ of the tobacco-box O, from each of which it receives one-third of its complement of tobacco, which is tamped by the three plungers M¹ M² M³ successively. The shaker Q prevents clogging of the tobacco as it descends. After receiving the last installment of tobacco and the last tamping from the plunger, it reaches the plug V, which pushes it upward so that the paper projects slightly above the top of the cylinder. As it passes the pin T¹ said pin descends and folds down about one-third of the circumference of the tube. It then passes under the plate T², which folds down about another third.

It then passes in front of the bar T³, which is pushed outward by the carrier P, and folds down the remaining third, so that it laps over the first and second folds. This completes the heading process, and the finished cigarette passes under the tube-former F, and is pushed out of the cylinder by said tube-former as it descends with a newly-formed tube.

It should be borne in mind that while one tube is going through the process above described other tubes are following it in the other chambers of the cylinder, and eventually and successively pass through the same process.

When the plug V rises in the chamber *n* and pushes up the filled cigarette, said plug at the same time arrests the cylinder N at the proper point to insure the discharge of the finished cigarette and the reception of another tube.

Having thus described my invention, I claim as new and desire to secure by Letters Patent—

1. The tube-former F, constructed as described, for receiving the paper and rolling it into a tube, substantially as and for the purpose specified.

2. The combination, in a cigarette-machine, of the winged case E and former F, as and for the purpose set forth.

3. The combination, in a cigarette-machine, of the paper-roll B, feed-rollers B² B², and blades C C² with the casing E, provided with wings *e e*, as and for the purpose specified.

4. The combination, with the tube-former F and its carrying-rod *f*, the gearing f² f³ f⁴ f⁵, the spring-pawls *g*, ratchet-wheel G, arm g², connecting-rod g⁴, and lever g⁵, of the arm *s*, carried by the main shaft S, for rotating the tube-former to roll the tube, substantially as herein described.

5. The combination, with the cylinder E and tube-former F, of the pivoted spring-levers H H², lever I, plate or arm I², sliding rods J J², levers *k k*², and cams s⁶ s⁷, carried by the main shaft S, for forming the first head on the paper tube or wrapper, substantially as herein described.

6. The combination, with the tube-former F and its carrying-rod *f*, provided with the adjustable collar f^x, of the cross-head M, operated by the rising and falling beam L², carried by the rock-shaft L, for depositing the paper tube in the chamber of the cylinder N, substantially as herein described.

7. The combination, with the cylinder N and its chambers *n*, of the tobacco-box O and its tubes o¹ o² o³, connected with cylinder for supplying the tobacco in installments, substantially as herein described.

8. The combination, with the cylinder N and its chambers *n*, and the tobacco-box O and its tubes connected with cylinder, of the reciprocating carrier P, provided with chambers for supplying the tobacco, and operated by the yoked lever R and the cam s⁹ on the main shaft S, substantially as herein described.

9. The combination, with the cylinder N and its chambers, and the tobacco-box O and its tubes, of the oscillating-plate Q and its tubes, the sliding rod q^4 and its spring, and the ratchet-cam s^{10} , carried by the main shaft, for preventing the clogging of the tobacco, substantially as shown and described.

10. The combination, with case E and tube F, in a cigarette-machine, of the depressible levers H H^2 , arranged as and for the purpose described.

11. The combination of the plungers M^1 M^2 M^3 , tubes o^1 o^2 o^3 , shaking plate Q, having tubes q^1 q^2 q^3 , and the revolving cylinder, having chambers n , as and for the purpose specified.

12. The combination of revolving cylinders, having chambers n , the pusher V, and the reciprocating folding pin T^1 , as and for the purpose described.

13. The combination, with cylinder N, having tubes n , of swinging arm T^3 , operated by the spring t^3 , and the carrier P, for completing the head, substantially as shown and described.

GEORGE H. HAYDEN.

Witnesses:

C. SEDGWICK,
E. R. BROWN.