

S. P. JACKSON.
Fastener for Meeting Rails of Sashes.

No. 211,513.

Patented Jan. 21, 1879.

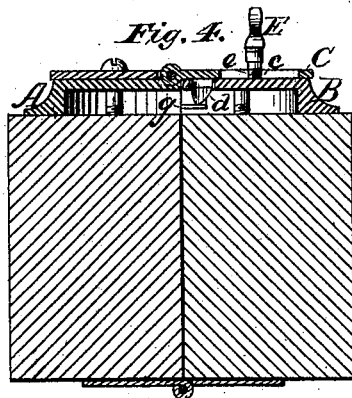
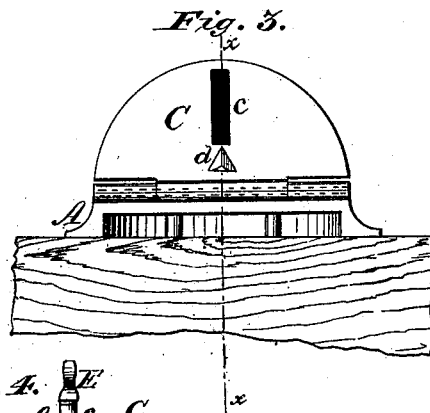
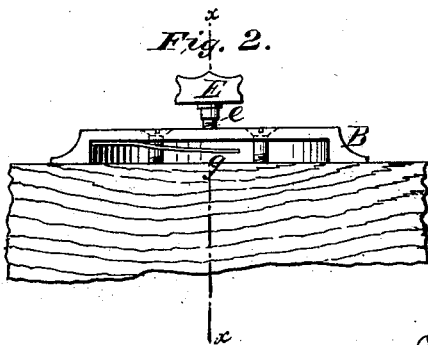
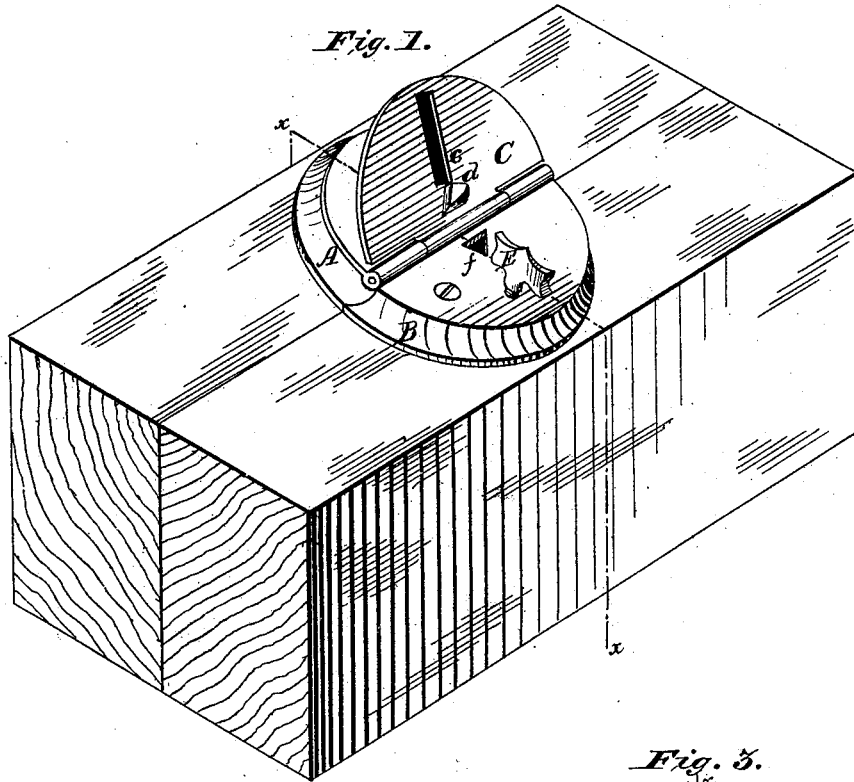

Witnesses:

J. C. Specht.
J. Rutherford

Inventor,

Samuel P. Jackson,

By James L. Norris
Attorney.

UNITED STATES PATENT OFFICE.

SAMUEL P. JACKSON, OF MANCHESTER, NEW HAMPSHIRE.

IMPROVEMENT IN FASTENERS FOR MEETING-RAILS OF SASHES.

Specification forming part of Letters Patent No. **211,513**, dated January 21, 1879; application filed July 23, 1878.

To all whom it may concern:

Be it known that I, SAMUEL P. JACKSON, of Manchester, in the county of Hillsborough and State of New Hampshire, have invented certain new and useful Improvements in Sash and Blind Fastenings, of which the following is a specification:

The object of this invention is to provide for sash and blinds a neat, cheap, efficient, and easily-operated fastening.

It consists of a divided base, the separate parts of which are adapted for attachment to opposite sashes or blinds, one of said parts having hinged to it a hasp, with an eye or slot cut therein and a pointed lug projecting therefrom, and the other part having a turn-button for engaging in the hasp, eye, or slot, and an opening for receiving the pointed lug of the hasp, the turn-button serving to prevent the hasp from being raised, and the engagement of the lug and opening preventing displacement of the sashes or blinds in any direction.

It consists, further, in the combination, with that part of the base having the opening for receiving the pointed lug, of a spring located in the path of the lug when introduced into the opening and the hasp having the said lug projecting therefrom, whereby, when the button is turned to its releasing position, the hasp will be automatically disengaged, so that the sashes or blinds may be separated without further manipulation of the fastenings.

In the accompanying drawing, Figure 1 is a perspective view of my invention, the hasp being raised. Fig. 2 is an edge view of the half-base carrying the button. Fig. 3 is an edge view of the half-base carrying the hasp. Fig. 4 is a section on line *x x*.

The letters A and B indicate the two parts of the divided base, the part A having hinged to it the hasp C, which is of the same size and shape in this instance as the top of the other half of the base. In this hasp C is cut an eye or slot, *e*, and between the inner end of this slot or eye and the hinge is located a tapering lug, *d*, which projects from the hasp.

The part B of the base has secured to it a turn-button, E, the shank of which is a screw, *e*, engaging in a screw-threaded hole in the base. Between this turn-button and the straight edge of that portion of the base to

which it is attached is an opening for receiving the lug *f*, which, in this instance, is cut through the top of the base portion; but the lug may be inverted and attached to base B, and an aperture cut in hasp C to receive it, and secure the same result. On the under side of the top of this base portion there is secured a tongue-spring, *g*, one end being free and extending under the opening *f* at such a distance from top of the base portion B that it will be struck by the lug *d* when the hasp is closed upon the base portion B.

When now the two portions of the base which have hereinbefore been described are secured by screws or otherwise to two opposite sashes or blinds, they should be so located with respect to each other that when the sashes or blinds are closed the hasp may be turned down upon the base portion B, and the turn-button E, having been properly turned, will pass through the eye or slot *e*, and the pointed lug *d* will enter the opening *f*. When the parts are brought to this position the hasp should be pressed closely upon the top of the base portion B, and the button E turned crosswise of the eye or slot *e*. The lug *d* will then have forced inward the spring *g*, subjecting it to tension, so that when it is desired to open the sashes or blinds it is only necessary to turn the button E to coincide with the slot or eye *e*, when the spring *g* will, by its resilience, throw the lug *d* out of the aperture *f*, thus effectually disengaging the two parts of the fastening.

When applied to sash the base portion A, having the hasp attached, is preferably secured to the top of the bottom rail of the top sash, and the portion B is secured to the top of the meeting-rail of the lower sash, as shown in Fig. 1.

I prefer to attach the turn-button E to the base by a screw-shank, in order that it may be adjusted when desired.

Should the two parts of the sash or blind become slightly displaced by warping, the ready engagement of the parts of the fastening will not be hindered, as, owing to the lug *d* being pointed, it will not fail to enter opening *f*, even though not centrally located, and when the hasp is pressed closely upon the base portion B the wedge-like action of one of the in-

clined sides will cause the two parts of the sash or blinds to be drawn to their proper position.

Having now fully described the construction and operation of my invention, I claim—

1. A sash or blind fastening consisting of a divided base, the separate parts of which are adapted for attachment to opposite sashes or blinds, one of said parts having hinged to it a hasp with an eye or slot cut therein, and a pointed lug projecting therefrom, and the other part having a turn-button for engaging in the hasp, eye, or slot, and an opening for receiving the pointed lug of the hasp, substantially as set forth.

2. The combination, with the base portion B and the hinged hasp C, having the pointed lug *d*, of a suitable spring for forcing said lug from its fastening engagement, substantially as described.

In testimony that I claim the foregoing I have hereunto set my hand in the presence of the subscribing witnesses.

SAML. P. JACKSON.

Witnesses:

WM. A. WEBSTER,
RICHARD J. P. GOODWIN.