

J. H. LEWIS.
Bench-Plane.

No. 211,516.

Patented Jan. 21, 1879.

Fig. 1

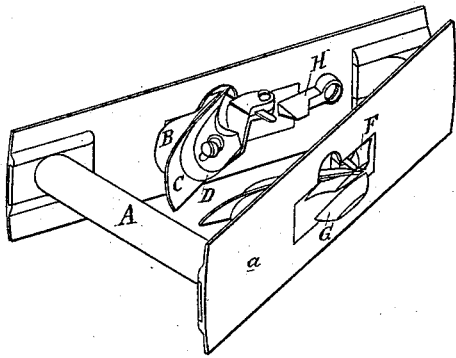

Fig. 2

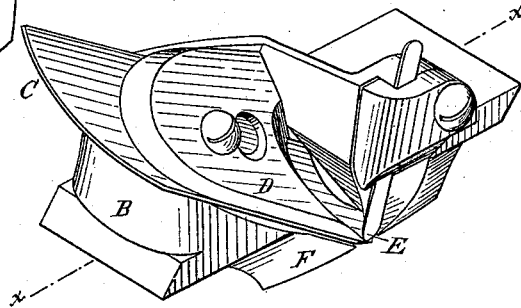

Fig. 3

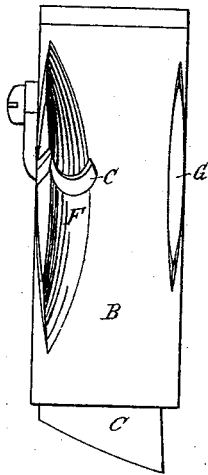
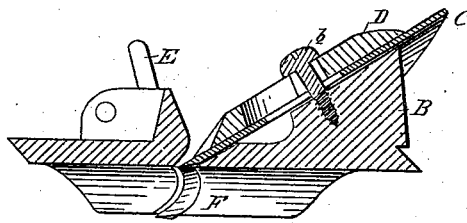

Fig. 4



Attest:
A. Barthel
N. S. Sprague

Inventor:
J. H. Lewis
By Atty
Thos. S. Sprague

UNITED STATES PATENT OFFICE.

JAMES H. LEWIS, OF DETROIT, MICHIGAN, ASSIGNOR OF ONE-HALF HIS
RIGHT TO GEORGE H. STELLWAGEN, OF SAME PLACE.

IMPROVEMENT IN BENCH-PLANES.

Specification forming part of Letters Patent No. **211,516**, dated January 21, 1879; application filed
September 18, 1878.

To all whom it may concern:

Be it known that I, JAMES H. LEWIS, of Detroit, in the county of Wayne and State of Michigan, have invented an Improvement in Bench-Tools, of which the following is a specification:

The nature of my invention relates to certain new and useful improvements in hand or bench tools of the plane class, and is particularly designed for use in sticking a bead or molding upon circle or irregular work.

The invention consists in a double-faced plane-stock, in which are removably secured proper heads, carrying the cutting-blades, all as more fully hereinafter set forth.

Figure 1 is a perspective view of my improved device ready for use. Fig. 2 is a perspective view of one of the cutter-heads removed. Fig. 3 is a bottom plan of the same, and Fig. 4 is a longitudinal section on the line *x x* in Fig. 2.

In the accompanying drawing, which forms a part of this specification, A represent a metallic stock with the plane-faces *a*, in which are cut proper openings to receive the heads and cutters, hereinafter described. B represent cutter-heads provided with throats. Upon these heads B are removably secured the blades C, which are held in position by means of the plates D and screws *b*, or in any other suitable manner. Adjustably secured to one side of the heads B are spur-blades E, which cut the straight side of the channel in a beading.

Extending downward from the faces of the heads B are two ribs, F G, the latter of which is oval in longitudinal section, while the inner face of the former has a contour corresponding to the cutting-edge of the blade C, which passes through it, and which produces the molding desired. The faces of these ribs are formed in the segment of a given circle.

When the heads are placed in the stock, they are held in position by buttons H, or other suitable means.

In practice, when it is desired to cut a bead or molding upon the inner edge of an arch or circle, the device is placed to its work, so as to cut with the grain, the rib G following the line of the edge of the board, while the blade C and spur-blade E cut the inner half of the bead and channel. To cut the remaining half of the bead, the device is reversed or turned over, and the other head used, as the nature of the work may require, so that the cut will always be with the grain.

While the ribs F G are formed in the segment of a given circle, the device is by no means limited to work in such circle, but can be used in work the radii of which is greater or upon straight work.

The heads carrying the cutting-blades may be constructed to cut different sizes, and be interchangeable, using but one stock for a set of heads.

What I claim as my invention is—

1. The double-faced triangular stock A, having the cutter-heads B on opposite sides, and the cutters C E, adjustably secured in such heads, substantially as and for the purposes set forth.

2. A bench-tool for cutting circular or irregular moldings, consisting of a double-faced triangular stock, A, cutter-heads B on opposite sides of said stock interchangeably held therein, cutters C E adjustably secured in such cutter-heads, guide-ribs E G, and button H, for holding the cutter-heads in position, all substantially as described and shown.

JAMES H. LEWIS.

Witnesses:

H. S. SPRAGUE,
A. BARTHEL.