

W. GALLOWAY.
Porous Refrigerator,

No. 211,562.

Patented Jan. 21, 1879.

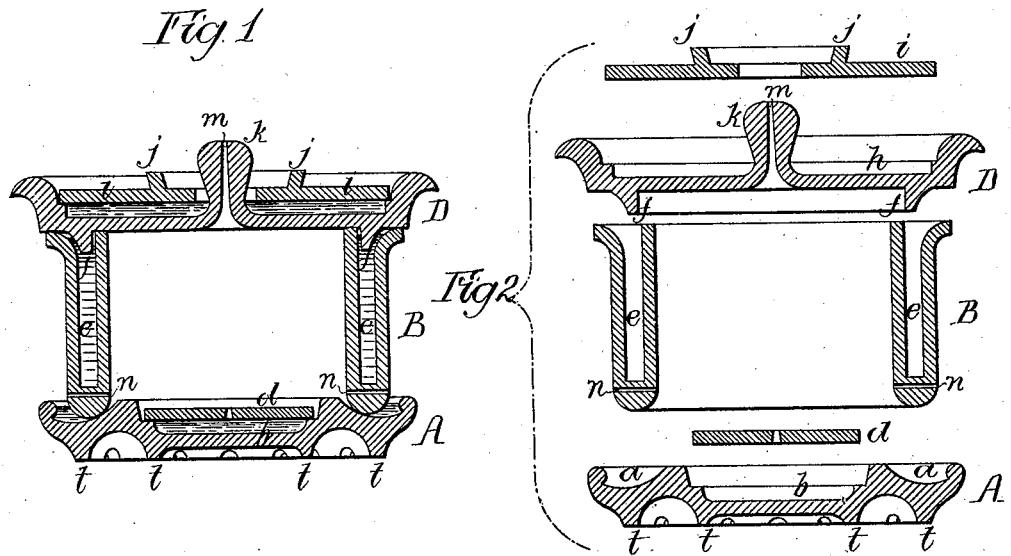

Witnesses,
Harry Smith
Thomas M. Swan

Inventor,
William Galloway
by his Attorneys
Howson and Son

UNITED STATES PATENT OFFICE.

WILLIAM GALLOWAY, OF PHILADELPHIA, PENNSYLVANIA.

IMPROVEMENT IN POROUS REFRIGERATORS.

Specification forming part of Letters Patent No. 211,562, dated January 21, 1879; application filed April 2, 1878.

To all whom it may concern:

Be it known that I, WILLIAM GALLOWAY, of Philadelphia, Pennsylvania, have invented a new and useful Improvement in Porous Refrigerators, of which the following is a specification:

My invention relates to certain improvements in that class of refrigerators which are made of porous earthenware, and the refrigerating effect of which is due to the evaporation of water which percolates from chambers contained within the walls of the refrigerator through to the surface of the same; and the main object of my invention is to construct the refrigerator of several parts, made detachable from each other, so that they can be readily cleansed.

In the accompanying drawing, Figure 1 is a vertical section of one form of my improved porous refrigerator, and Fig. 2 the same, showing the parts detached from each other.

A is the base, B the body, and D the cover, of the refrigerator, all being made of porous earthenware, the base, which is preferably of circular form, having an annular recess, *a*, for receiving the lower end of the body and for containing a supply of water, the latter serving as a seal to prevent the external air from entering the interior of the refrigerator, between the body and base of the same.

In the middle of the base is a recess, *b*, to which is fitted a detachable plate, *d*, the said plate having one or more openings.

The body B, of porous earthenware, which I prefer to make of cylindrical form to accord with the circular base, has double walls, so as to form an annular chamber, *e*, for a supply of water, this chamber being open at the top for receiving an annular rib, *f*, on the under side of the cover D, a portion of the rib being immersed in the water, which thus seals the joint between the cover and the body.

There is a recess, *h*, in the upper side of the cover for containing water, and a ledge on the edge of this recess bears a detachable plate, *i*, of earthenware, which can be raised from its bearings by the aid of the beveled ribs *j*, so as to permit access to the recess *h* for cleansing purposes.

The cover has a central knob, *k*, passing

through a central opening in the plate *i*, and projecting above the same, so as to serve as a handle, by which the cover may be raised from the body, and a small opening, *m*, extends entirely through the cover and knob. A number of small openings, *n*, are also formed in the body B, near the lower edge of the same.

The base A of the refrigerator is supported upon annular ribs *t*, which are notched, so as to permit the access of air to the under side of said base, and thus increase the available surface presented for evaporation.

It will be seen, on reference to Fig. 2, that all the parts can be detached from each other in order to subject them from time to time to a thorough cleansing.

The opening *m* in the cover of the refrigerator and the openings *n* in the body of the same insure proper ventilation of the interior of the refrigerator, as they permit the passage through the latter of currents of air, which carry off the foul air and gases generated from the contents of the refrigerator, while the openings are too small to neutralize the refrigerating effects produced by the evaporation of the moisture on the exterior of the vessel, where it is exposed to the air.

I am aware that refrigerators have been made of porous earthenware with chambers for containing water, and that the recess *a* for receiving the lower edge of the body of the refrigerator is not new. These features, therefore, I do not claim; but

I claim as my invention—

A porous refrigerator in which are combined a base, A, body B, and cover D, each made detachable from the others, the base A containing a water-chamber covered by a detachable plate, *d*, the body B containing a water-chamber open at the top, and the cover D containing a water-chamber covered by a detachable plate, *i*, all substantially as specified.

In testimony whereof I have signed my name to this specification in the presence of two subscribing witnesses.

WM. GALLOWAY.

Witnesses:

HARRY A. CRAWFORD,
HARRY SMITH.