

A. S. HAPGOOD.  
Edging and Planing Machine.

No. 211,569.

Patented Jan. 21, 1879.

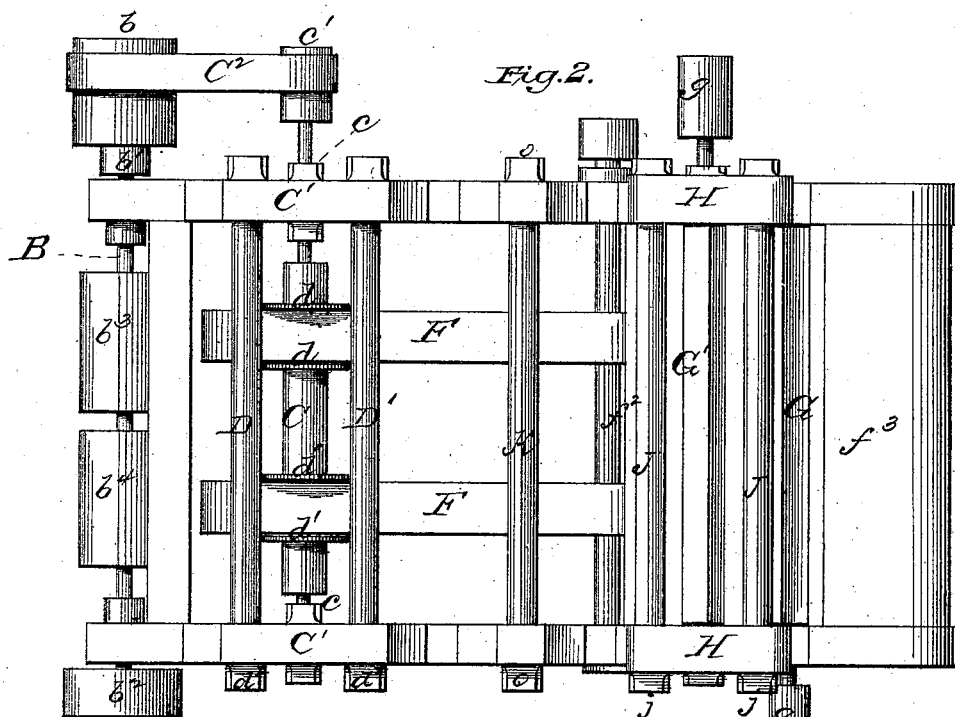
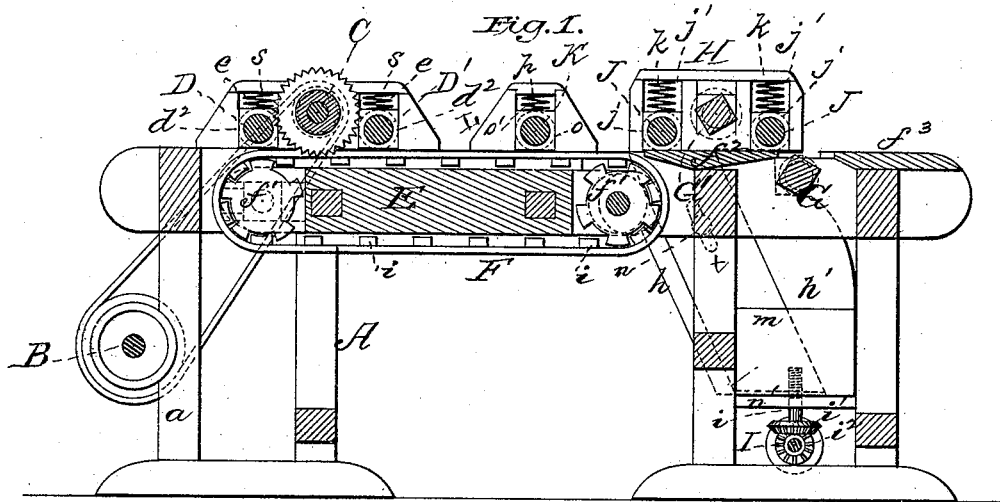

WITNESSES  
*John Allen*  
*F. J. Massi*

INVENTOR  
*A. S. Hapgood*  
*Wm. W. Anderson*

ATTORNEY

# UNITED STATES PATENT OFFICE.

ANDREW S. HAPGOOD, OF SOUTH WATERFORD, MAINE, ASSIGNOR TO  
HIMSELF AND L. A. COBB, OF SAME PLACE.

## IMPROVEMENT IN EDGING AND PLANING MACHINE.

Specification forming part of Letters Patent No. 211,569, dated January 21, 1879; application filed  
December 14, 1878.

*To all whom it may concern:*

Be it known that I, ANDREW S. HAPGOOD, of South Waterford, in the county of Oxford and State of Maine, have invented a new and valuable Improvement in Combined Edger and Planer; and do hereby declare that the following is a full, clear, and exact description of the construction and operation of the same, reference being had to the annexed drawings, making a part of this specification, and to the letters and figures of reference marked thereon.

Figure 1 of the drawings is a side elevation of my machine. Fig. 2 is a plan or top view of the same.

This invention has relation to improvements in combined edging and planing machines.

The object of the invention is mainly to devise an edger and planer of a simple and economical construction that will smooth both sides of a piece of lumber and shave its edges simultaneously into exact parallelism with each other.

The nature of the invention consists in combining, in an edger and planer with a frame, a driving-shaft journaled therein and provided with driving and driven pulleys, of pillow-blocks erected on said frame, and provided with vertical slots, boxes in said slots, bearing-down rollers journaled in said boxes, holding-down springs, and a saw-arbor arranged between said rollers, and provided with the saws, arranged in pairs, and adjustable to or from each other.

It also consists in certain novel constructions and arrangements of parts, as will be hereinafter more fully set forth and claimed.

In the annexed drawings, the letter A indicates a strong upright frame, of rectangular form and of suitable materials, affording in its rear end uprights *a*, forming bearings to a driving-shaft, B, carrying at one end the pulleys *b* *b*<sup>1</sup>, at the other a single pulley, *b*<sup>2</sup>, and at its middle portion a fixed pulley, *b*<sup>3</sup>, and a loose pulley, *b*<sup>4</sup>. This driving-shaft is rotated, by means of an endless belt passing around pulley *b*<sup>3</sup>, by a suitable motor, which belt may be shifted to the loose pulley *b*<sup>4</sup>, and the rotation of shaft B stopped without stopping the motor.

C indicates a saw-arbor, having its bearings in boxes *c*, arranged in cheek-blocks C<sup>1</sup> erected upon the frame, and carrying two sets of saws; *d* *d*<sup>1</sup>, arranged in pairs. The saws of each set are adjustable to or from each other upon their arbor, according to the width of the stuff to be edged. The arbor C is actuated by means of an endless belt, C<sup>2</sup>, passing around a pulley, *c*<sup>1</sup>, upon the said arbor and the pulley *b* on the driving-shaft.

D D' indicate holding-down cylinders, arranged one at each side of the saw-arbor, and having their bearings in the boxes *d*<sup>2</sup> of the cheek-blocks C<sup>1</sup>. The boxes *d*<sup>2</sup> are arranged and vertically movable in slots *s* of the said blocks, and the cylinders are held down to their work by means of suitable springs *e*, placed in the slots *s* above the boxes *d*<sup>2</sup>, as shown in Fig. 1.

E indicates strong longitudinal beams, arranged parallel to each other, and carrying in their forked ends the toothed pulleys *f*<sup>1</sup>. These beams extend from the rear of the saws to a table, *f*<sup>2</sup>, near the front end of the main frame, and one is appropriated to each set of saws—that is, one passes between each pair of saws. F designate endless belts, passing around the pulleys *f*<sup>1</sup> aforesaid, and supported by the beams E. These belts have on their under sides lugs *i*, with which the teeth of the cogged pulleys *f*<sup>1</sup> engage, thus imparting motion to the said belts. In front of the table *f*<sup>2</sup> is arranged a planer, G, having its bearings in the top of the main frame, and situated between the said table *f*<sup>2</sup> and a table, *f*<sup>3</sup>, on a level therewith. The planer G derives motion from the main-shaft by means of an endless belt passing over a pulley, *g*, on the end of the journal of said planer and the pulley *b*<sup>2</sup> aforesaid.

Planer G is in stationary bearings, and is composed usually of a body of prismatic form, and of cutting blades or bits removably and adjustably secured thereto, and is designed to smooth the under side of a piece of lumber.

*h* *h*<sup>1</sup> indicate spaced parallel guides, obliquely arranged to the horizontal plane, and receiving between them the stem or shank *m* of the cheek-blocks H, that afford bearings in their middle portions to the journals of the

upper planer, G'. These stems are obliquely slotted, and confined to the main frame by means of a screw, *n*, passing through said slot into the main frame. The lower edge of the tongues rest upon horizontal ledges *n'* projecting from frame A, and affording a seat to an adjusting-screw, *i*, having on its lower end a beveled gear, *i*<sup>1</sup>. The upper ends of the screws *i* are in contact with the lower edges of the tongues, and their bevel-gears *i*<sup>1</sup> engage corresponding gears *i*<sup>2</sup> upon a transverse shaft, I. This shaft has its bearings in the frame under the ledges *n'*, and is rotated to adjust the upper planer for various thicknesses of plank.

By rotating shaft I rotary motion is imparted to the adjusting-screws, and the tongues of the cheek-blocks H raised or lowered in an equal degree, as the case may be, thus increasing or lessening the space between the upper and lower planers, according to the thickness of the boards to be dressed.

The cheek-blocks H, at each side of the upper planer, have a holding-down roller, J, the extremities of which are journaled in boxes *j*, arranged in slots *j'* in the said blocks, and having a spring, *k*, usually of spiral form, in the upper part of said slot, bearing down upon the said boxes. These have free endwise motion in the slots *j'*, and adapt themselves automatically to various thicknesses of board. Between the saw-arbor and the upper planer, G', is another holding-down roller, K, having its bearings in boxes *o*, arranged in vertical slots *o'* in cheek-blocks L on the frame A. These boxes are held down in the lower part of slots *o'* by means of a spring, *p*, placed in said slots above the said boxes.

The operation of my improved edger and planer is as follows: The boards to be planed are placed, two at a time, upon the table *f*<sup>3</sup>, and their ends introduced between the upper and lower planers, G' G. They are then pushed or fed along until they reach the endless conveyer-belts F F, which seize upon them and convey them accurately to the pair of edger-saws *d d*<sup>1</sup>, passing between which their edges are evenly and smoothly trimmed.

During the feeding of the boards the holding-down rollers J press them against the tables *f*<sup>2</sup> *f*<sup>3</sup>, and the rollers K D D' press them upon the belts F, which, being supported by the beams E, are incapable of sagging. Usually the outside surface of these belts is roughened or provided with projections, that take hold upon the boards and feed them accurately to the saws.

It will be seen from the foregoing description that both sides of the boards are planed

and both edges trimmed, so that after passing through the machine they are ready for use. It will also be seen that the adjustment of the upper planer according to the thickness of the boards is readily and expeditiously obtained, and that, while the rollers bear upon the boards with sufficient force to hold them, they readily adjust themselves to different thicknesses of boards.

What I claim as new, and desire to secure by Letters Patent, is—

1. In a combined edger and planer, the combination, with the frame A, a driving-shaft, journaled therein and provided with driving and driven pulleys, of the blocks C<sup>1</sup>, erected on said frame, and provided with vertical slots *s*, the boxes *d*<sup>2</sup>, arranged in said slots, the rollers D D', journaled in said boxes, the springs *e*, and the saw-arbor C, arranged between said rollers and provided with the saws *d d*<sup>1</sup>, arranged in pairs and adjustable relative to each other, substantially as set forth.

2. The combination, with the arbor C, having the saws *d d*<sup>1</sup>, arranged in pairs and adjustable to or from each other, the beams E, arranged between said saws, the cogged wheels *f*<sup>1</sup>, in the ends of said beams, and the endless belts F, having lugs *i* upon their insides, arranged and operating substantially as specified.

3. In combination with the planer G, the vertically-adjustable planer G', and the tables *f*<sup>2</sup> *f*<sup>3</sup>, the automatic holding-down rollers J J at each side of planer G', and adjustable therewith, the arbor C, the adjustable saws *d d*<sup>1</sup>, arranged in pairs on said arbor, the beams E E, having cogs *f*<sup>1</sup> in their ends, the endless belts F, having lugs *i*, and the holding-down rollers K D D', substantially as specified.

4. The combination, with the frame A, provided with oblique guides *h h'* and the planer G, of the pillow or cheek blocks H, having stems or tongues *m*, the bearing rollers J J', journaled in said blocks, the planer G', journaled in said blocks between the rollers J, a slot, *t*, in tongues *m*, a screw, *n*, passing through said slot into the frame, the ledges *n'*, the adjusting-screws *i*, having gears *i*<sup>1</sup>, the shaft I, having beveled gears *i*<sup>2</sup>, and a manipulating-wheel on said shaft, substantially as specified.

In testimony that I claim the above I have hereunto subscribed my name in the presence of two witnesses.

ANDREW S. HAPGOOD.

Witnesses:

CHAS. YOUNG,  
E. W. AYER.