

C. A. LAWTON & E. W. ARNDT.  
 Bran-Dusters.

No. 211,576.

Patented Jan. 21, 1879.

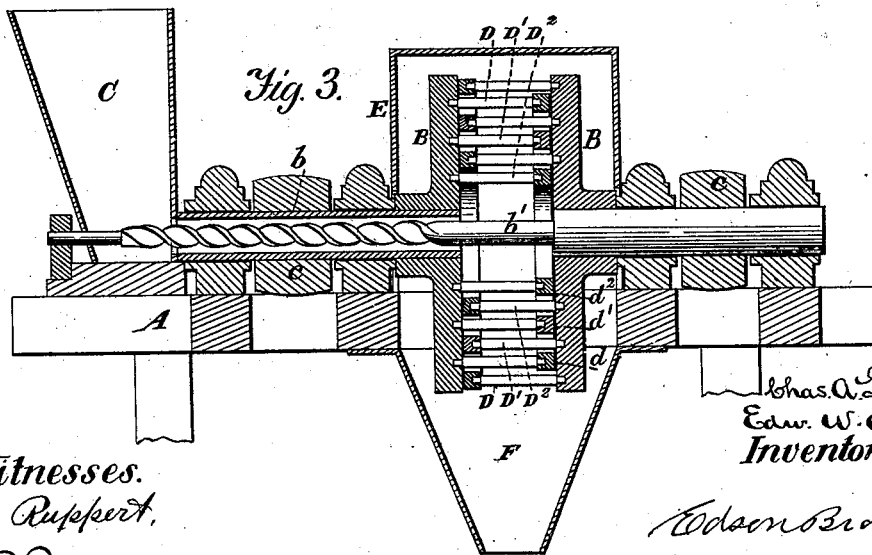
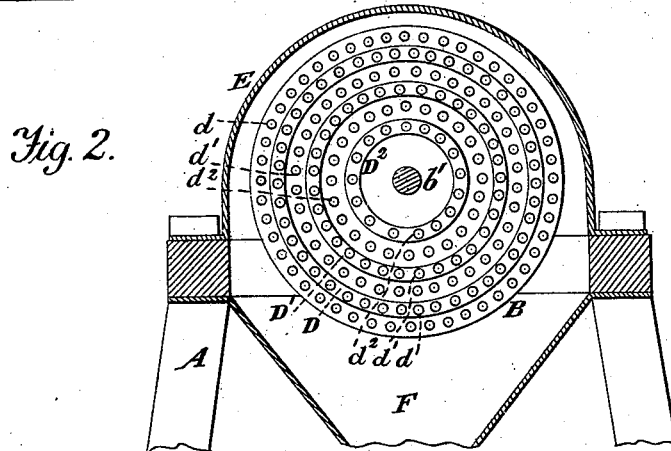
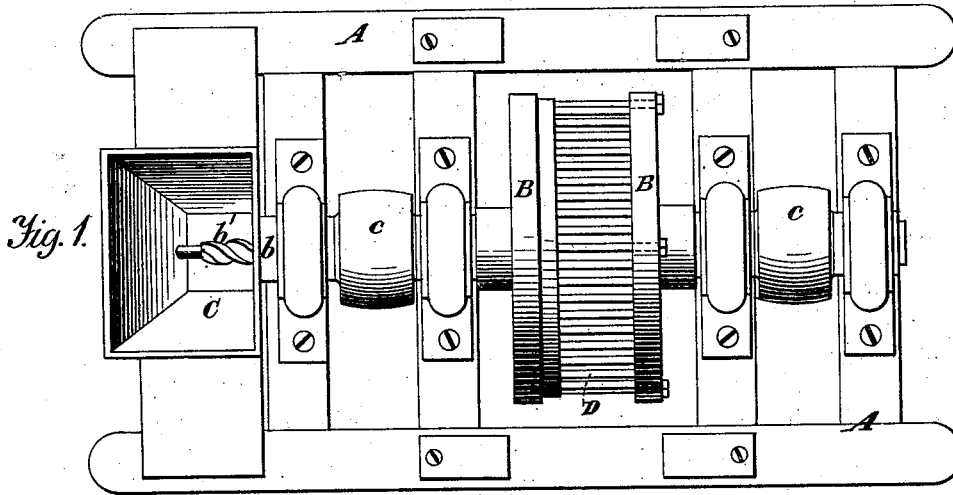

Witnesses.  
 A. Ruppert,  
 S. P. Berthrong.

Chas. A. Lawton,  
 Edw. W. Arndt,  
 Inventors.

Edson Brothers  
 Attorneys.

# UNITED STATES PATENT OFFICE.

CHARLES A. LAWTON AND EDWARD W. ARNDT, OF DE PERE, WISCONSIN.

## IMPROVEMENT IN BRAN-DUSTERS.

Specification forming part of Letters Patent No. 211,576, dated January 21, 1879; application filed April 1, 1878.

*To all whom it may concern:*

Be it known that we, CHARLES A. LAWTON and EDWARD W. ARNDT, of De Pere, in the county of Brown and State of Wisconsin, have invented certain new and useful Improvements in Bran-Dusters; and we do hereby declare that the following is a full, clear, and exact description thereof, which will enable others skilled in the art to which they appertain to make and use the same, reference being had to the accompanying drawings, and to the letters of reference marked thereon, which form a part of this specification, and in which—

Figure 1 represents a plan view of our improved bran-duster; Fig. 2, a transverse section; and Fig. 3 is a longitudinal section thereof.

Corresponding parts in the several figures are denoted by like letters.

This invention relates to certain improvements in bran-dusters; and it consists, principally, of two inter-operative disks, provided with two or more series of arms or beaters, arranged in concentric circles and in connection with a feeding-shaft, and revolving in opposite directions, and also in a certain peculiar construction of said beaters, substantially as hereinafter more fully set forth.

In the annexed drawings, A refers to a frame or support. B B mark two disks or plates, secured one upon a hollow shaft, *b*, and the other upon a spiral or feeding shaft, *b'*, mounted in suitable bearings upon the frame A. Upon these shafts are pulleys *c c*, for driving the same. The shaft *b'* extends through the shaft *b* to a hopper, C, into which the bran is fed and conducted to the duster. The disks or plates B B are each provided with one or more series of arms or beaters, D D<sup>1</sup> D<sup>2</sup>, arranged in concentric circles, the free ends of which are set in rings *d d<sup>1</sup> d<sup>2</sup>*, suitably fastened thereto by clamping rods or bolts, as shown. The peripheries of these rings extend slightly beyond the arms or beaters, to avoid contact between the several series or circles of said arms or beaters. The several circles of arms or beaters of one disk, B, fit alternately in between those of the other disk, and the said disks are revolved in opposite directions, causing their respective arms or beaters

to move past each other in contrary directions, and thus as the bran is fed thereto by the shaft *b'* produce a separation of the bran from the flour and middlings adhering thereto.

Fitting over and covering these parts is a case or cover, E, preferably buttoned to the frame or support A. Below the ribs or beaters is fastened to the frame A a chute, F, for the discharge of the bran from said beaters or arms.

By the use of the rings *d d<sup>1</sup> d<sup>2</sup>* the arms or beaters can be made lighter, as they are thus strengthened and more firmly held in position, and consequently possess greater efficiency in the performance of their work. The arms or beaters D D<sup>1</sup> D<sup>2</sup> are free to rotate in their disks and rings, and are thereby rendered more capable of resisting wear in use, as they are slowly rotated by their violent action on the material when in operation, and the wear is thereby equalized upon their entire surfaces.

By the use of our machine the bran, in passing through the same, is subjected to a whipping or percussion action while in a state of suspension. The effect of this is to separate or remove all farinaceous particles of wheat from the bran in the form of middlings, which constitute the most valuable or rich ingredient of the wheat. The middlings are passed through a purifier, and form the highest grade of flour.

As heretofore practiced, by grinding, brushing, rubbing, or scraping the bran to remove the farinaceous particles, an inferior grade of flour has been produced almost invariably. The great desideratum has been, and is, to grind as high as possible—that is, as coarse as possible—without wasting by making too rich bran. The objection to pursuing this course has been that the profit gained by the extra percentage of middlings has been more than overcome by the richness of the bran. This is entirely avoided by our process, and without the disadvantages attending those heretofore employed in producing their best grade of flour.

The advantages arising from using our machine or process are, that it is possible to grind higher, and consequently cooler, (thus avoiding the destroying of the life of the flour,)

and with less power. There will be less medium and more high-grade flour.

It will be further observed that the bran, from the time it leaves the hopper until it is finally discharged from the cages, is held in a state of suspension, and that during its passage through the cages it has no lodging-place; hence it is subjected to a thorough and continuous disintegrating action, bringing about the results above set forth.

It will here be noticed that it is the intention of applicants to make the process herein described the subject of either a reissue or a separate application for patent.

It will be understood that we do not limit ourselves to the number of cages or the number of beaters or bars in each cage.

Having thus described our invention, what we claim, and desire to secure by Letters Patent, is—

1. The combination of hopper and disks or plates B B, provided with two or more concentric series of beaters, D D<sup>1</sup> D<sup>2</sup>, and jour-

naled upon shafts *b b'*, provided with independent driving-pulleys, the shaft *b'* being formed hollow, and the shaft *b* being provided with a spiral feeding-shaft extending into shaft *b'*, substantially as described.

2. The combination of a disk or plate, a ring or rings secured thereto, and beaters, each being free to rotate, substantially as set forth.

3. The combination, in a beating or disintegrating machine, of a disk or plate, a ring, a set of beaters, each free to rotate, and having their bearings in the plate and ring, and clamping-rods for securing the rings to the disks, substantially as set forth.

In testimony that we claim the foregoing as our own we hereunto affix our signatures in the presence of two witnesses.

CHARLES A. LAWTON.  
EDWARD W. ARNDT.

Witnesses:

E. F. PARKER,  
P. R. PROCTOR.