

T. F. LONGAKER.
 Measuring Attachment for Faucets.

No. 211,577.

Patented Jan. 21, 1879.

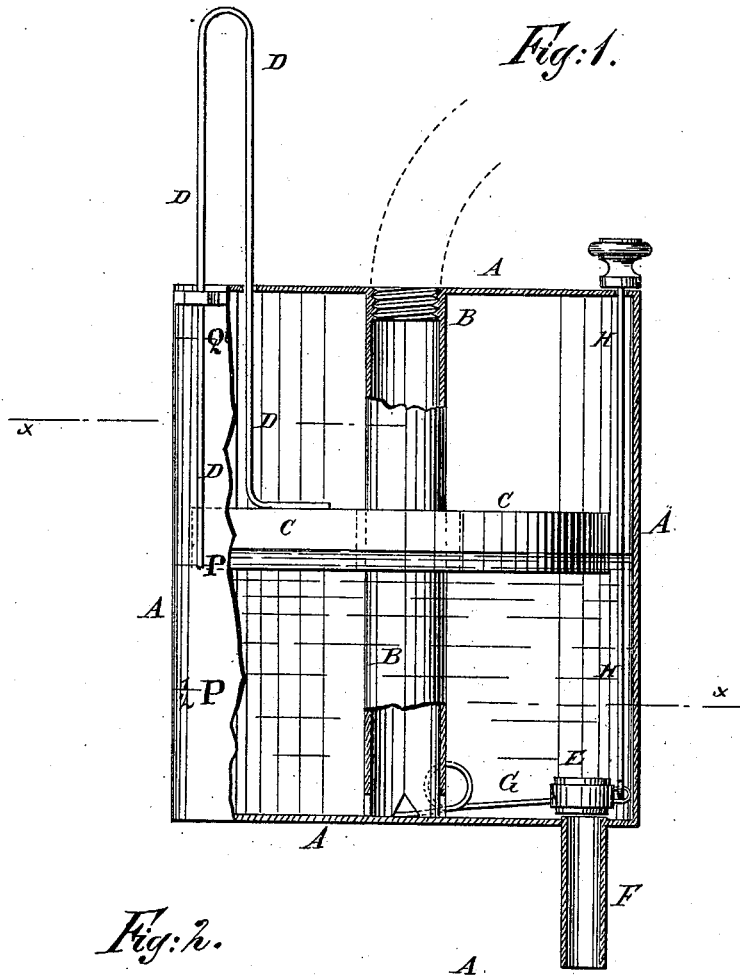
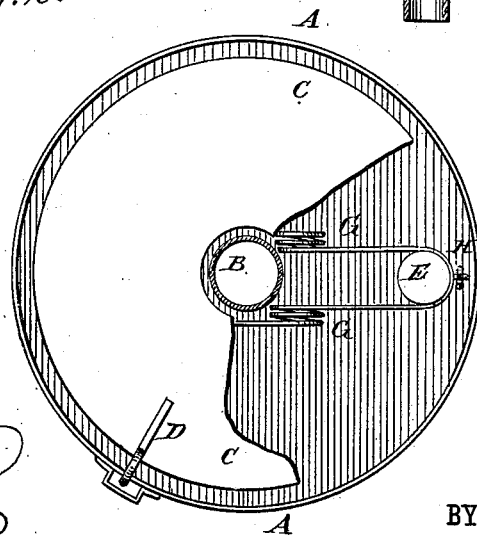

Fig. 1.



WITNESSES:

Chas. Nida
Wm. Sedgwick

INVENTOR:

T. F. Longaker
 BY *Mumford*

ATTORNEYS.

UNITED STATES PATENT OFFICE.

THOMAS F. LONGAKER, OF WEST PHILADELPHIA, PENNSYLVANIA.

IMPROVEMENT IN MEASURING ATTACHMENTS FOR FAUCETS.

Specification forming part of Letters Patent No. 211,577, dated January 21, 1879; application filed October 4, 1878.

To all whom it may concern:

Be it known that I, THOMAS F. LONGAKER, of West Philadelphia, in the county of Philadelphia and State of Pennsylvania, have invented a new and useful Improvement in Measuring Attachments for Faucets, of which the following is a specification:

Figure 1 is a side view of my improved device, partly in section, to show the construction. Fig. 2 is a detail section of the same, taken through the broken line *x x*, Fig. 1.

Similar letters of reference indicate corresponding parts.

The object of this invention is to furnish an improved device for attachment to faucets for measuring liquids as they are drawn from a can or cask, and which shall be simple in construction and convenient and accurate in use, and will prevent the liquid from being spilled and its odor from escaping into the room.

The invention will first be described in connection with the drawing, and then pointed out in the claim.

A is a can made with a close bottom and top, and of such a size as to contain a quart or any other desired quantity.

In the center of the can A is placed a tube, B, the lower end of which is secured to the bottom of the said can A, and has openings in its sides, to allow the liquid flowing into it to flow out into the lower part of the said can A. The upper end of the tube B passes through and is secured to the top of the can A, and has a screw-thread cut in its inner surface, to adapt it to be screwed upon the nozzle of a faucet.

C is an air-tight hollow box or float, which fits loosely into the can A, and has a hole formed through its center to receive and slide freely upon the tube B. To the float C is attached a wire, D, which passes up through a hole in the top of the can A, to indicate the rise of the float C, and consequently the

amount of liquid that has entered the said can A.

The quantity of liquid may be indicated by painting the different parts of the wire D of different colors, or by painting graduation-marks upon it; or the wire D may be extended and bent over into U-form, with its outer arm extending down along the outer side of the can A, so that its end may point to graduation-marks upon the side of the said can A. When the indicator D indicates the desired quantity, the faucet is closed, and the valve E is opened to allow the liquid to flow out through the nozzle F, secured in a hole in the bottom of the can A, into a bottle, can, or other receiver.

The valve E is held down to its seat by a wire or other spring, G, and is provided with a rubber or other suitable packing to insure a close joint. The valve E is opened by a wire, H, attached to it, and which passes out through a hole in the top of the can A, and has a knob or other handle attached to its upper end for convenience in operating it.

If desired, the spring G may be connected with the wire H at the top of the can A; or two springs may be used, one connected with the valve E, and the other with the wire H.

With this device the liquid can be drawn, measured, and placed in the receiving-vessel without spilling any of it, and without allowing the room to be permeated with its odor.

Having thus described my invention, I claim as new and desire to secure by Letters Patent—

A liquid-measure provided with a float, C, guided on a central supply-tube, B, as and for the purpose set forth.

THOMAS F. LONGAKER.

Witnesses:

R. M. GROVES,
CHAS. E. PANCOAST.