

W. WHARTON, Jr.
 Railroad-Crossing.

No. 211,607.

Patented Jan. 21, 1879.

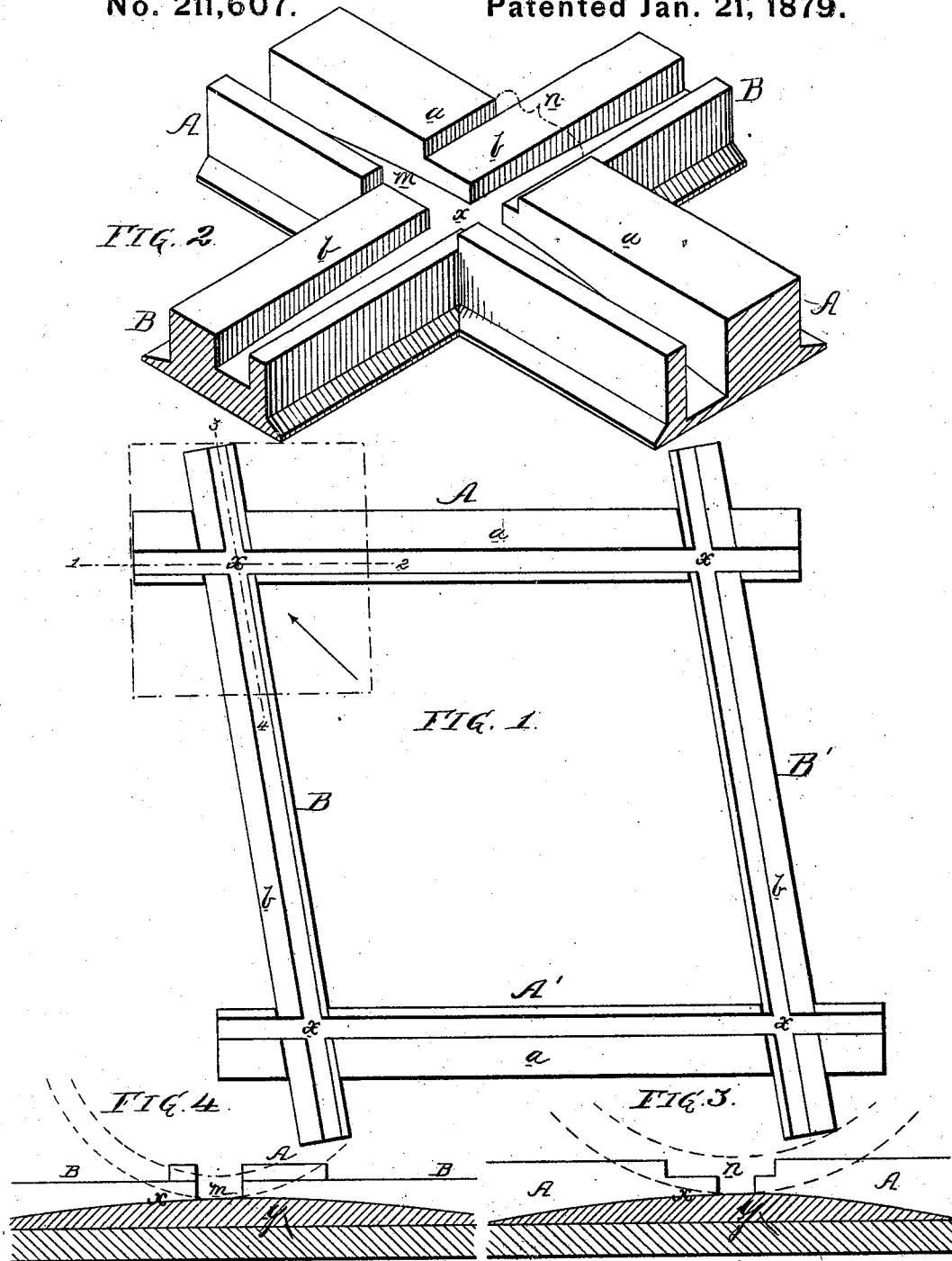

Witnesses
 Henry Howson Jr.
 Harry Smith

Inventor
 William Wharton Jr.
 by his Attorneys
 Howson & Co.

UNITED STATES PATENT OFFICE.

WILLIAM WHARTON, JR., OF PHILADELPHIA, PENNSYLVANIA.

IMPROVEMENT IN RAILROAD-CROSSINGS.

Specification forming part of Letters Patent No. **211,607**, dated January 21, 1879; application filed December 2, 1878.

To all whom it may concern:

Be it known that I, WILLIAM WHARTON, JR., of Philadelphia, Pennsylvania, have invented a new and useful Improvement in Railroad-Crossings, &c., of which the following is a specification:

My invention relates to that class of railroad frogs or crossings in which car-wheels traversing one track have flanges differing in depth from those which traverse the intersecting track—as, for instance, where a track for horse-cars crosses a track for steam-cars; and the object of my invention is to so construct such a crossing that both kinds of wheels will traverse it without being injuriously influenced by the gaps for the passage of the flanges of the wheels.

In the accompanying drawings, Figure 1 is a plan view of my improved railroad-crossing; Fig. 2, a perspective view, looking in the direction of the arrow, of the portion of Fig. 1 indicated by dotted lines; Fig. 3, a vertical section on the line 1 2, and Fig. 4 a vertical section on the line 3 4.

The crossing is composed of the two grooved rails A A', the treads of which coincide with those of the rails of the track of an ordinary steam-road, and two grooved rails, B and B', of the intersecting track of a city or horse car road. The crossing may be made of cast-iron, or of wrought iron or steel-bars properly secured together.

It will be observed on reference to Fig. 2 that the treads *a* of the rails A A' are higher than the treads *b* of the intersecting rails B B', this difference in altitude being equal to the difference between the depth of the flanges of the wheels which traverse the steam-road and that of those which traverse the city or horse road, as will be understood by reference to Figs. 3 and 4, the dotted segments in which indicate the difference in the depth of the flanges in the two kinds of wheels.

At each intersection of the grooves in the crossing there is a bearing, *x*, for the flanges of the wheels which traverse both grooves, this bearing being at such a point below the tread *b* of the rail B, Fig. 2, that the flange of the wheel of a street-car as it passes the

intersection will ride over the bearing *x*, and the wheel will be very slightly elevated thereby, but sufficiently to pass freely across the gap *m*, formed in the rail B, for the passage of the flanges of the wheels which traverse the intersecting track. In other words, the bearing *x* enables the wheel of a street-car to cross the gap *m* without being subjected to the shocks which would ensue in the absence of this bearing. In like manner the flanges of the wheels which traverse the tread *a* of the rail A of the steam-track ride over the same bearing *x*, which prevents the treads of the said wheels from being injuriously affected by the gap *n*, made in the rail A of the steam-track for the passage of the wheels of the street-car, which traverse the rail B of the intersecting track.

I prefer to make the bearings *x* of filling-pieces of steel, snugly fitted in the groove and secured by dovetailing, or by bolts or otherwise, providing they can be readily removed when worn to make way for new filling-pieces.

It will be understood that my invention is applicable to all intersections of two tracks where the flanges of the wheels traversing one track are not of the same depth as those of the intersecting track.

I do not desire to claim, broadly, a crossing in which there are bearings for the flanges of car-wheels at the intersection of the rails, as this is shown in the patent of Macferran and Kneass, No. 23,101, March 1, 1859, in which, however, all the rails are of the same height; but

I claim as my invention—

In a railroad frog or crossing having intersecting rails of unequal height, a bearing, *x*, for the wheel-flanges, combined with the bearing-surface of the rails, so as to form a support for flanges of unequal depth, substantially as set forth.

In testimony whereof I have signed my name to this specification in the presence of two subscribing witnesses.

WILLIAM WHARTON, JR.

Witnesses:

HENRY HOWSON, Jr.,
HARRY SMITH.