

R. M. HOE.
Paper-Folding Machine.

No. 211,848.

Patented Feb. 4, 1879.

Fig. 1.

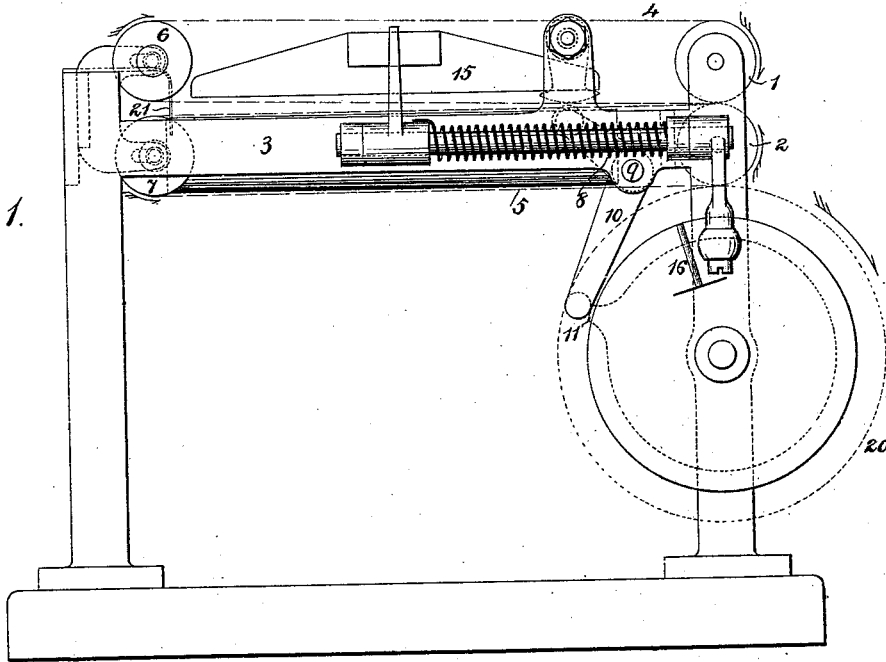
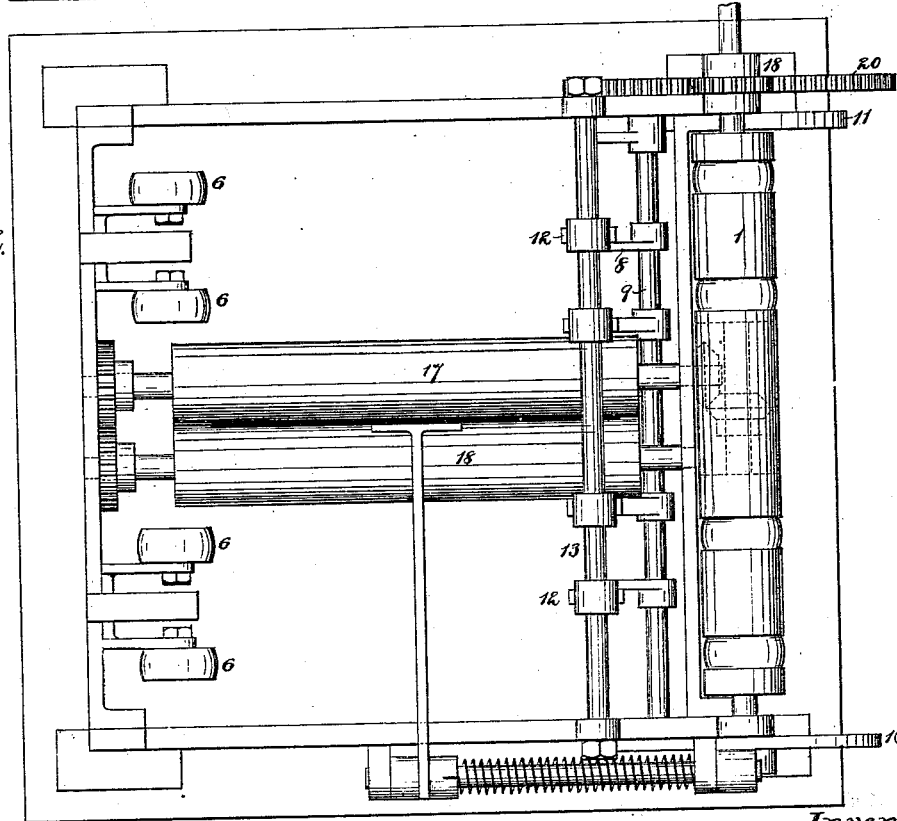

Fig. 2.



Witnesses
Geo. D. Graham.
J. R. Ely.

Inventor
Richard M. Hoe
 By *Munson & Philipp*
 Attorneys

R. M. HOE.
Paper-Folding Machine.

No. 211,848.

Patented Feb. 4, 1879.

Fig. 3

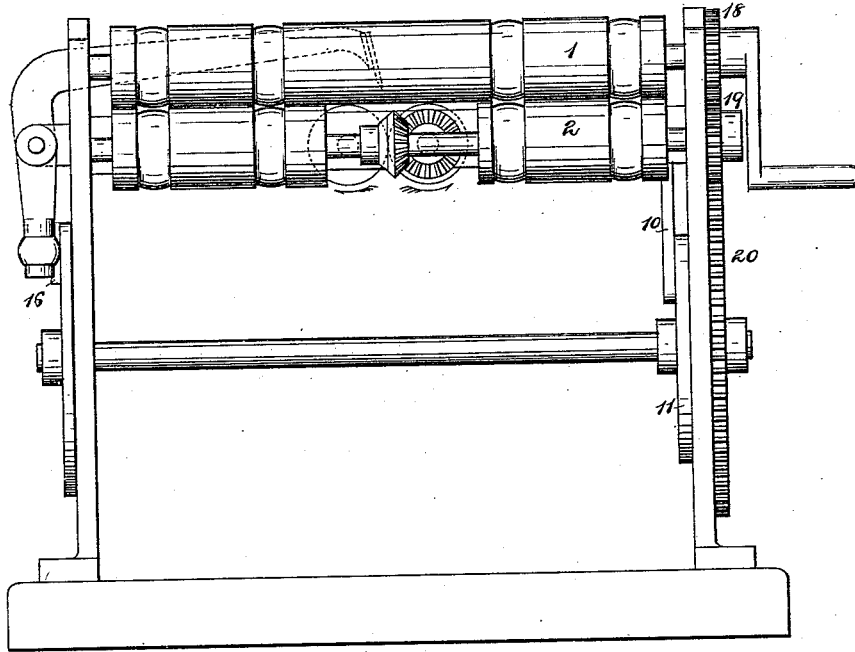

Fig. 4.

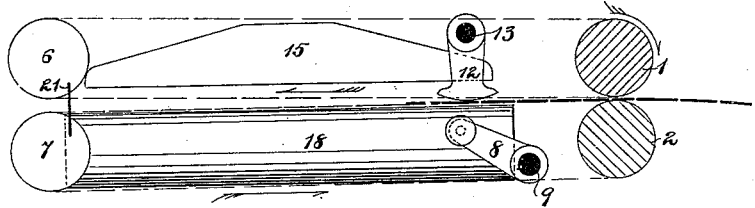
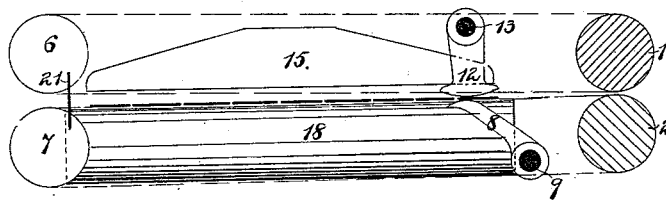

Fig. 5.



Witnesses
C. M. Graham
J. R. Ely

Inventor
Richard M. Hoe
By *Munson & Philipp*
Attorneys

UNITED STATES PATENT OFFICE.

RICHARD M. HOE, OF NEW YORK, N. Y.

IMPROVEMENT IN PAPER-FOLDING MACHINES.

Specification forming part of Letters Patent No. 211,848, dated February 4, 1879; application filed October 26, 1877.

To all whom it may concern:

Be it known that I, RICHARD M. HOE, of the city, county, and State of New York, have invented certain new and useful Improvements in Paper-Folding Machines; and I do hereby declare the following to be a full, clear, and exact description of the same, reference being had to the accompanying drawings, forming a part of this specification, in which—

Figure 1 is a side elevation of a folding-machine containing my invention. Fig. 2 is a top-plan view of the same. Fig. 3 is an end view of the same. Figs. 4 and 5 are views, partly in section, showing the position of the devices when in operation for carrying out my invention.

My invention relates to folding-machines supplied at a high rate of speed with sheets to be folded, and particularly to that class of folding-machines adapted to work in conjunction with a perfecting printing-press, which prints from a web of paper, cuts it into sheets of proper size, and delivers them as rapidly as cut and printed. Where these sheets pass directly into a folding-machine they move with such velocity that great difficulty is experienced in arresting them in such relation to the folding mechanism as to be folded accurately upon a given line without buckling.

The object of my invention is to overcome this difficulty; and it consists in sheet-controlling mechanism, by which the movement of the sheet with respect to the folding mechanism is so governed as to secure its position in relation to the folding mechanism at the time when said folding mechanism operates to double it, as will be more fully hereinafter described and claimed.

Referring to the drawings, numbers 1 and 2 represent rollers suitably journaled in the frame-work 3 of the machine, geared together, and driven by gearing, as represented in the drawings, or in any other convenient manner. Over these rollers 1 and 2 tapes 4 and 5 pass to and around stretching-pulleys 6 and 7, of any desirable construction. These tapes gradually separate from the point where the rollers 1 and 2 seize the sheet to be folded to the stretching-pulleys 6 and 7, for a purpose hereinafter described.

The sheet-controlling mechanism consists,

essentially, of brake-arms 8 and rest-blocks 12. These brake-arms are shown as secured to a rock-shaft, 9, to which is secured a lever, 10, in contact, through a pin thereon, with a cam, 11, positively rotated in any convenient way. The ends of these brake-arms may be slightly curved where they operate upon the paper, as shown in Fig. 5, or may be provided with friction-rollers, as shown in Figs. 1 and 4.

The rest-blocks 12 may be secured firmly to a rigid shaft, 13, at any desired point, so as to operate in connection with the brake-arms 8, to retard the paper as it moves in the machine.

15 is a folding-blade, the arm of which is pivoted to the frame of the machine and operated by a positively-driven cam, 16, or in any other convenient manner. This folding-blade operates in conjunction with a pair of folding-rollers, 17 and 18, rotated in timely relation to the rollers 1 and 2 in any convenient manner.

21 is a gage, of any common construction, against which the edge or leading end of the sheet may rest, if desired, before the folding-blade operates to double it into the bite of the rollers 17 and 18.

In operation, the sheet supplied, either from a table, a printing-press, or a folding mechanism that has previously imparted a fold or folds to it, to the rollers 1 and 2, is led through the same, partially carried by the tapes, into position over the folding-rollers 17 and 18. Just before it arrives into the proper position or register to be folded by the blade 15 and folding-rollers 17 and 18, the brake-arms 8, through their rock-shaft 9 and its operating-cam 11, are elevated, and their ends raise the sheet and press it near its rear end momentarily, or for such time as practice may determine, in contact with the rest-blocks 12, so as to suspend or retard its movement and enable its forward edge or leading end to slowly approach the gage 21, gently abut against the same, and adjust itself in contact therewith without danger of displacement; and the tapes 4 and 5, being partially separated near the stretching-pulleys 6 and 7, above referred to, obviate to a great extent smutting, that might arise from the stopping of the sheet while the tapes continued to move. Upon the movement of the cam 11

the brake-arms 8 are lowered, and their ends being moved away from the sheet, it is free to be doubled by the folding-blade 15 into the bite of the folding-rollers 17 and 18.

By changing the form and movement of the cam 11 the brake-arms 8 may be so operated in relation to the rest-blocks 12, to retard or stop the sheet, as to cause it to be carried into the proper position or register to be folded upon any predetermined line without the use of a gage. The rollers 1 and 2 may be those for making the first or any other fold of the sheet, or they may be feeding-rollers, as shown in the drawings. The form or number of the brake-arms and rest-blocks may be varied from those shown in the drawings without departing from my invention, so long as they operate to control the sheet, as above referred to.

Having thus described my invention, what I claim as new, and desire to secure by Letters Patent, is—

1. The combination of a folding mechanism and a mechanism for controlling or checking the movement of the traveling sheet, all substantially as described.

2. The combination of a sheet-feeding mechanism, a mechanism for controlling or checking the movement of the traveling sheet, and a sheet-folding mechanism, all substantially as described.

3. The combination of a rotating feeding mechanism, operating to deliver a sheet to folding devices, and mechanism intermittently moved into contact with the moving sheet to partially arrest or modify the speed thereof, all substantially as described.

4. The brake-arms, in combination with rest-blocks, for controlling the movement of the sheet, substantially as described.

5. The combination of brake-arms, rest-blocks, and supporting carrying-tapes, substantially as described.

6. The combination of brake-arms, rest-blocks, carrying-tapes, and gage, substantially as described.

7. The combination of the brake-arms 8, rest-blocks 12, rock-shaft 9, provided with an arm, 10, and cam 11, substantially as described.

8. The combination of the brake-arms and rest-blocks with a gage for controlling the movement of the sheet, substantially as described.

In testimony whereof I have signed my name to this specification in the presence of two subscribing witnesses.

RICHD. M. HOE.

Witnesses:

H. T. MUNSON,
M. B. PHILIPP.