

J. BARRY.  
 Steam-Cylinder Lubricator.

No. 211,881.

Patented Feb. 4, 1879.

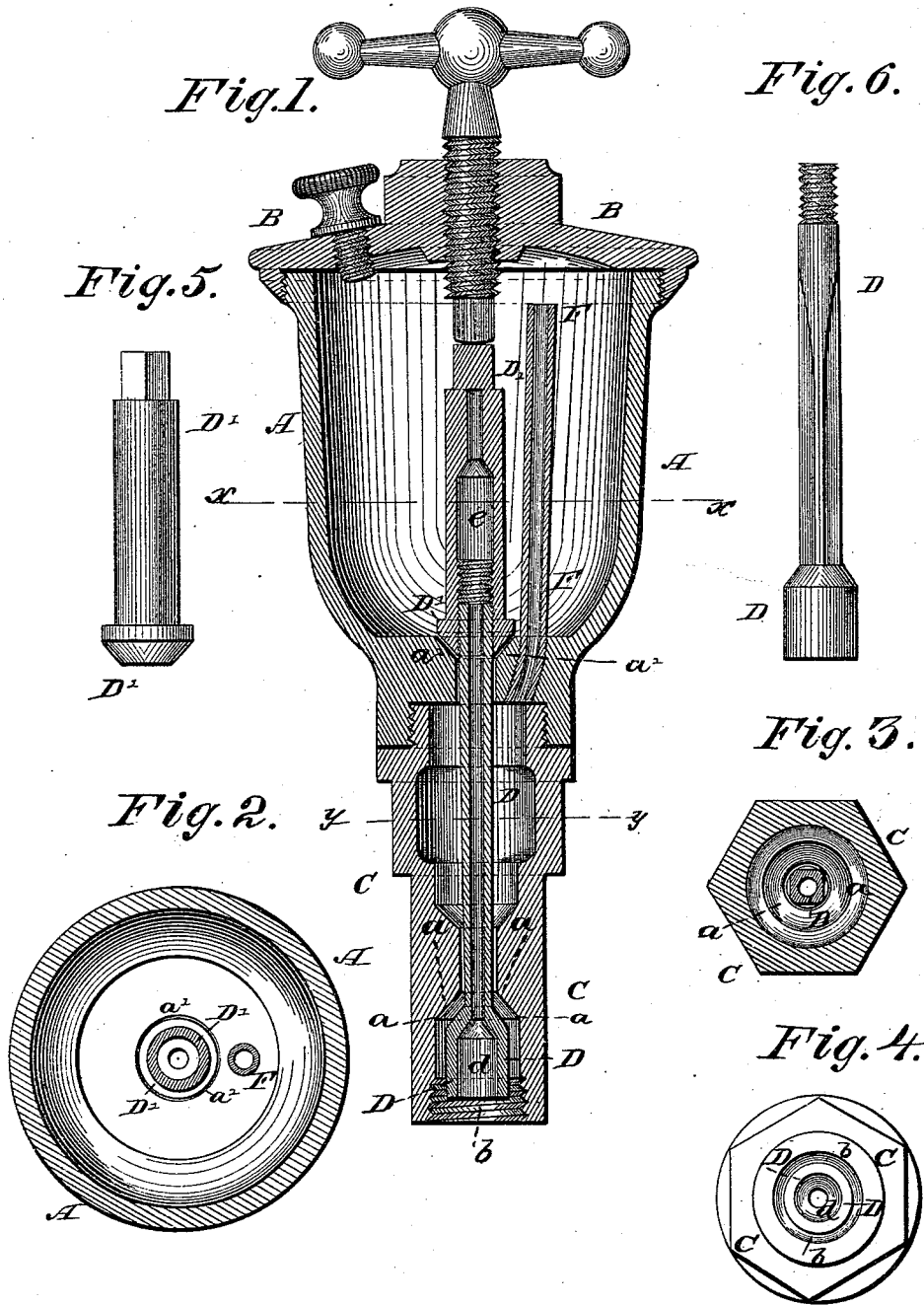

Witnesses:

*P. H. Dietrich*  
*Frank A. Duffy*

per

Inventor:  
*James Barry*  
*C. H. Watson & Co* Attorneys.

# UNITED STATES PATENT OFFICE.

JAMES BARRY, OF AUBURN, NEW YORK, ASSIGNOR TO HIMSELF AND  
JOSEPH BARRY, OF SAME PLACE.

## IMPROVEMENT IN STEAM-CYLINDER LUBRICATORS.

Specification forming part of Letters Patent No. **211,881**, dated February 4, 1879; application filed  
September 10, 1878.

*To all whom it may concern:*

Be it known that I, JAMES BARRY, of Auburn, in the county of Cayuga and State of New York, have invented certain new and useful Improvements in Steam-Cylinder Lubricators; and I do hereby declare that the following is a full, clear, and exact description of the invention, which will enable others skilled in the art to which it appertains to make and use the same, reference being had to the accompanying drawings, and to the letters of reference marked thereon, which form a part of this specification.

The nature of my invention consists in the construction and arrangement of a steam-cylinder lubricator, as will be hereinafter more fully set forth.

In the annexed drawings, to which reference is made, Figure 1 is a central vertical section of a lubricator embodying my invention. Fig. 2 is a transverse section on line *xx*, Fig. 1. Fig. 3 is a similar section on line *yy*, Fig. 1; and Figs. 4, 5, and 6 represent detail views of my invention.

A represents the oil-cup, provided with the cover B, screwed thereon so as to be perfectly tight. In the bottom of the cup A is screwed the hollow stem C, to form the connection with the part to be lubricated. This hollow stem forms, as it were, a lower reservoir, and in the same is formed a valve-seat, *a*, with a valve, D, closing upward against the same by the action of the live steam. In the bottom of the cup A is formed the valve-seat *a'*, with the valve D' closing downward against the same.

It will be noticed that the lower valve, D, is made about half an inch shorter than the stem C below the valve-seat *a*, thus forming a reservoir, *b*, for steam.

F represents a pipe in the cup A, to conduct air to the lower reservoir or cylinder, which prevents the condensed and hot air from rising.

I have found by experiment that when the lower valve is opened the condensed water and hot air in the steam-chest will not only prevent the oil from discharging into the cylinder, but will also completely fill the lower chamber or reservoir with condensed water. By the employment of the tube F comparatively cold air is conveyed from the upper reservoir to the lower reservoir, and keeps the con-

densed water and hot air down, and thus lets the oil discharge freely into the cylinder.

The lower valve, D, is made somewhat shorter—say half an inch, more or less—than the stem C of the cup, and thus forms a reservoir at *b* for steam. This valve is cupped out at the bottom, as shown at *d*, and the valve and valve-stem are made hollow to conduct the steam to the upper valve, D'. The object of this is to melt the tallow, which must be done before it will discharge into the cylinder.

The two valves D D' are made separate, and connected by screw-threads or other suitable means to make a steam-tight joint.

The upper valve, D', is formed with a chamber or opening, *e*, in it, which is made larger than that in the stem connecting the two valves. When the openings in both upper valve and stem are of the same size the steam will not rise; but when the upper valve is provided with a chamber larger than the opening in the stem the steam will rise and melt the oil or tallow.

I am aware that it is not new in lubricators of this class to have two valves, with the steam passing through the lower valve into the upper to heat the latter, and thereby melt the tallow in the cup, and I do not claim such, broadly, as my invention.

Having thus fully described my invention, what I claim as new, and desire to secure by Letters Patent, is—

1. In a steam-cylinder lubricator having an oil-cup with stem and two valves, an air-pipe, F, for conducting air from the upper to the lower reservoir, substantially as herein set forth.

2. The upper valve, D', provided with an enlarged chamber, *e*, in combination with the lower cup-shaped valve, D, having the hollow stem, connecting with the upper valve, and the stem C, forming a steam-reservoir, *b*, around and below the lower valve, D, substantially as and for the purposes herein set forth.

In testimony that I claim the foregoing as my own I have hereto affixed my signature in presence of two witnesses.

JAMES BARRY.

Witnesses:

E. H. COBB,  
SAML. F. REYNOLDS.