

M. DALEY.
Hand-Carts.

No. 211,889.

Patented Feb. 4, 1879.

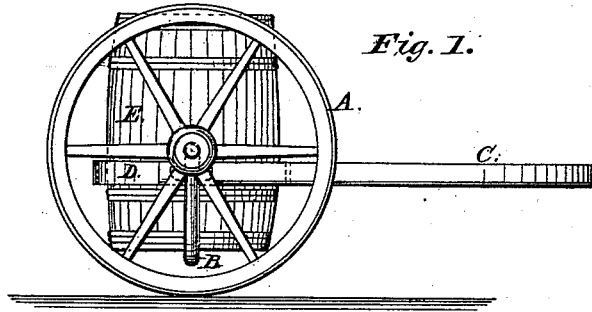

Fig. 1.

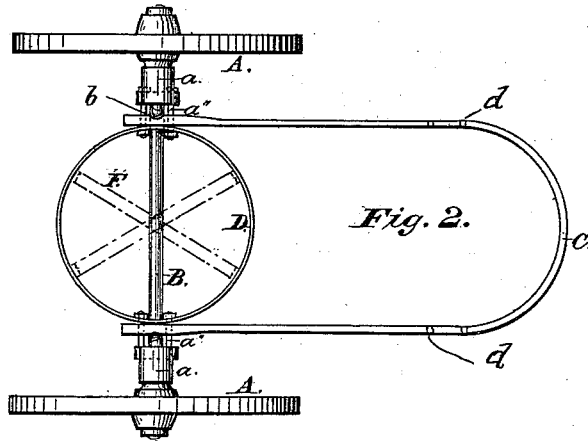

Fig. 2.

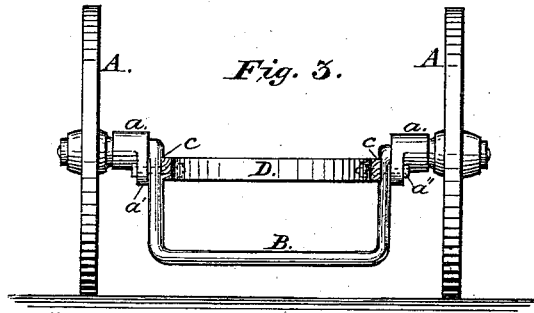

Fig. 3.

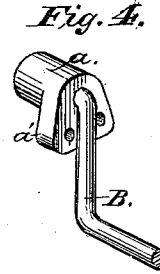

Fig. 4.

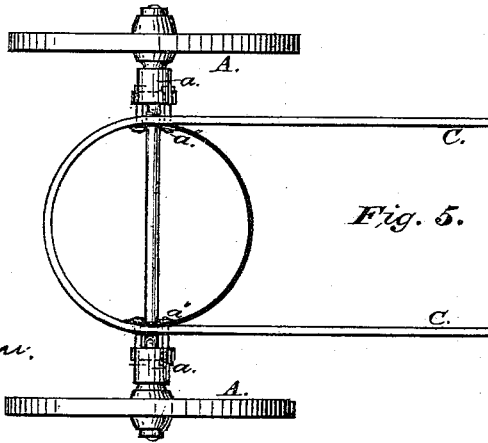

Fig. 5.

Witnesses:
J. Buckingham.
Jno. D. Patten.

Inventor:
Michael Daley
by G. H. W. Howard
att'y.

UNITED STATES PATENT OFFICE.

MICHAEL DALEY, OF WATERMAN, ILLINOIS.

IMPROVEMENT IN HAND-CARTS.

Specification forming part of Letters Patent No. **211,889**, dated February 4, 1879; application filed June 15, 1878.

To all whom it may concern:

Be it known that I, MICHAEL DALEY, of Waterman, in the county of De Kalb and State of Illinois, have invented certain Improvements in Hand-Carts, of which the following is a specification, reference being had to the accompanying drawings, and to the letters of reference marked thereon.

The invention relates to a hand-cart to be employed for carrying swill, water, or other liquids, the improvements consisting in the construction of certain parts of the cart, which are hereinafter fully described.

The object of the invention is to balance the barrel or cask which holds the swill or other liquid, to give steadiness to the cart when drawn or pushed, and to facilitate the partial turning over or tilting of the cask when the liquid is to be emptied therefrom.

In the drawings annexed, Figure 1 is a side view of the invention, including a barrel or cask. Fig. 2 is a plan of the cart without the barrel. Fig. 3 is an end view of the same, partly in section. Fig. 4 is an enlarged view of a part of the invention, as hereinafter fully described. Fig. 5 shows the invention in a modified form.

Similar letters of reference indicate similar parts of the invention in all the figures.

A A are the wheels, which are placed on the axle B. The axle is preferably of round cross-section, but may be made square or of other shape. The axle continues straight for a short distance inward from the hub of each wheel, when it is bent downward at each side to about a right angle, and then turned horizontally, forming a crank-axle, as shown. Upon the axle, just within the hubs of the wheels, are placed collars or shoulder-pieces *a*, each of which has a vertical face, *a'*, cut out or grooved to receive a portion of the adjacent downward bend of the axle, the use of said shoulder-pieces being to strengthen the bends and prevent their change of shape when subjected to sudden shocks.

C is the handle, which I prefer to make of a single pole bent to the form shown; but separate shafts may be used, if desired. D is a support for the barrel, box, or cask, preferably circular in form, but which may be made

square or any other convenient shape. The handle C, or the separate shafts, if employed, are notched at their ends *b*, to fit over the down bends of the axle, as shown at *c*, and they, with the support D, are firmly secured to the collars or shoulder-pieces *a* by bolts *a''*.

The barrel, (represented by E,) resting in the support D, as shown in Fig. 1, is about equally placed above and below the same, and balanced so that in pulling or pushing the cart perfect steadiness and freedom from oscillation are observed.

When it is desired to empty the cask the handle C is raised, and the cask thereby tilted.

In Fig. 5 the rounded or bent end of the handle C is reversed or placed next to the axle, in which case only one-half of a support, D, is needed to complete the circle.

Holes *d d* are placed in the handle, to enable it to be reversed in the manner described, which holes would receive the bolts *a''*.

The parts shown in dotted lines by F form a hanging rest for the cask, which may be used in addition to the support D, and connected to the opposite sides thereof. In the construction shown in Fig. 5 the rests F would be attached to the half-support D and the semi-circular end of the handles C.

The axle, support, and handle may be made entirely of iron or entirely of wood; or wood and iron may be used together in their construction.

The barrel may rest upon the axle, and be also supported by the support D, in which case the bend of the axle is just sufficient to allow the bottom of the cask to rest upon it, while the center of the cask is surrounded by the support; or the cask may be sustained wholly by the support, in which case the axle is bent down sufficiently to just clear the bottom of the cask.

This invention is found to be useful and convenient for the various purposes for which it is intended, and is capable of being made so as to have both the elements of strength and cheapness.

What I claim as new, and wish to secure by Letters Patent, is—

1. The combination, in a hand-cart, of wheels, a bent axle, a cask-support, and a handle,

formed of a single pole, and bent as shown, and provided with bolt-holes, adapting it to be reversed, as specified.

2. The combination, in a hand-cart, of wheels, a bent axle, a cask-support, and collars or shoulder-pieces, fitted upon and serving to strengthen the bends of the axle near the hubs, substantially as set forth.

3. The combination of the wheels A A, bent axle B, handle C, support D, with or without

the hanging rest F, shoulder-pieces *a*, and bolts *a'*, the whole being arranged substantially in the manner set forth.

In testimony whereof I have hereto subscribed my name this 13th day of April, A. D. 1878.

MICHAEL DALEY.

Witnesses:

W. H. YEARNSHAW,
C. F. MIGHELL.