

J. FINN.
Rowlock.

No. 211,899.

Patented Feb. 4, 1879.

Fig. 1.

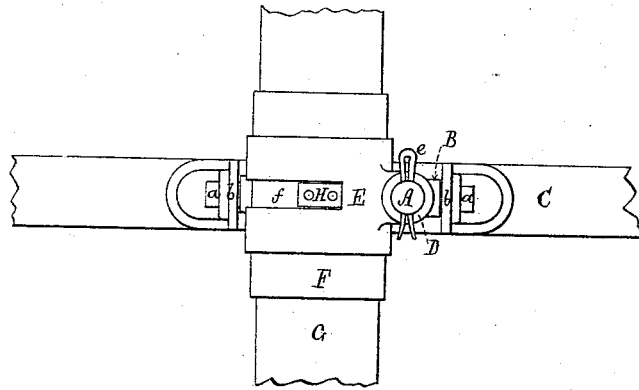

Fig. 2.

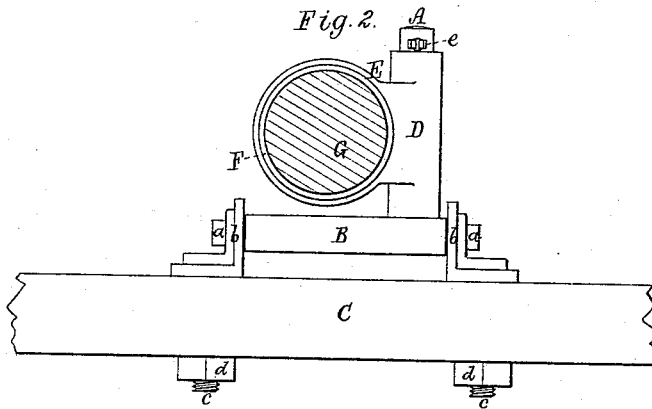
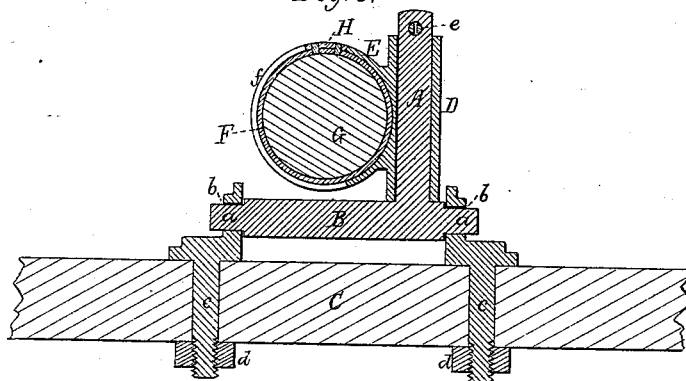

Fig. 3.



Witnesses.

S. M. Piper.
M. Sullivan

Inventor

James Finn.

by attorney.

R. H. Eddy

UNITED STATES PATENT OFFICE.

JAMES FINN, OF BOSTON, MASSACHUSETTS.

IMPROVEMENT IN ROWLOCKS.

Specification forming part of Letters Patent No. **211,899**, dated February 4, 1879; application filed December 24, 1878.

To all whom it may concern:

Be it known that I, JAMES FINN, of Boston, of the county of Suffolk and State of Massachusetts, have invented a new and useful Improvement in Rowlocks; and do hereby declare the same to be described in the following specification and represented in the accompanying drawings, of which—

Figure 1 is a top view, Fig. 2 a front elevation, and Fig. 3 a longitudinal section, of a rowlock of my improved kind applied to an oar and the gunwale of a boat.

Such rowlock consists of a pintle or journal, a rock-shaft, a rotary bearing, a slotted collar, and a sleeve provided with a stop to enter the slot of the collar, all being arranged and applied substantially as set forth.

In the drawings, A denotes the pintle or journal, fixed to a rock-shaft, B, and projected at right angles therefrom, the journals *a a* of such shaft resting in bearings *b b*, arranged on the top of a gunwale, C, and fastened thereto by screw-bolts *c c* and nuts *d d*. Encompassing the said pintle is a rotary bearing, D, which is held on the pintle by a key, *e*, going through the pintle at the top of the bearing. The said bearing projects from a short tube or collar, E, having a slot, *f*, arranged in and partly around it, as shown, the journal being disposed tangentially to the collar, and firmly connected therewith, as shown.

The collar encompasses and is concentric with a cylindrical tube or sleeve, F, which encircles and is fixed, or is to encircle and be fixed, upon the shank of the oar, part of such shank being shown at G. As the bearing D swivels freely on the pintle, and as the latter can vibrate laterally of the gunwale, it will readily be seen that the rowlock will admit of all the necessary rowing motions of the oar for advancing a boat, and also will admit of the oar, when its blade is curved lengthwise,

being partially revolved, so as to be used in backing the boat.

There extends from the sleeve F into the slot of the collar a projection, H, which not only serves, with the slot, to keep the collar and sleeve in connection, but also to limit the rotary motion of the oar, in order to bring it into either of its positions for being used in advancing or backing the boat.

With this rowlock the oar may be turned either within or without the boat, so as to range alongside of the gunwale thereof.

On withdrawing the key from the pintle, the oar, with the collar, sleeve, and bearing, can be removed from connection with the pintle.

I do not claim a rowlock as represented in the United States Patent No. 189,135, in which the outer of its two rings has guides pivoted in the arms of a furcated pintle to extend into the gunwale, as I have no such pintle, but apply the pintle of my rowlock by different means to the gunwale, and, as a consequence, have with it a tubular bearing, as described, fixed to the slotted collar, the same enabling me to turn this one down inside of and below the gunwale, or outside of it, as explained.

I claim—

1. The combination of the rock-shaft B and pintle A, the tubular bearing D, slotted collar E, the sleeve F, and the projection H, arranged and applied, and for use as a rowlock, substantially as set forth.

2. The combination of the tubular bearing D, slotted collar E, and the sleeve F and its projection H, arranged and for application, as described, to an oar, and for use, as explained, with a pintle pivoted to the gunwale, so as to be capable of being moved transversely thereof.

Witnesses:

R. H. EDDY,
S. N. PIPER.

JAMES FINN.