

R. HEATHFIELD.

Coating Sheet-Iron with Zinc or with Alloys of Zinc.

No. 211,905.

Patented Feb. 4, 1879.

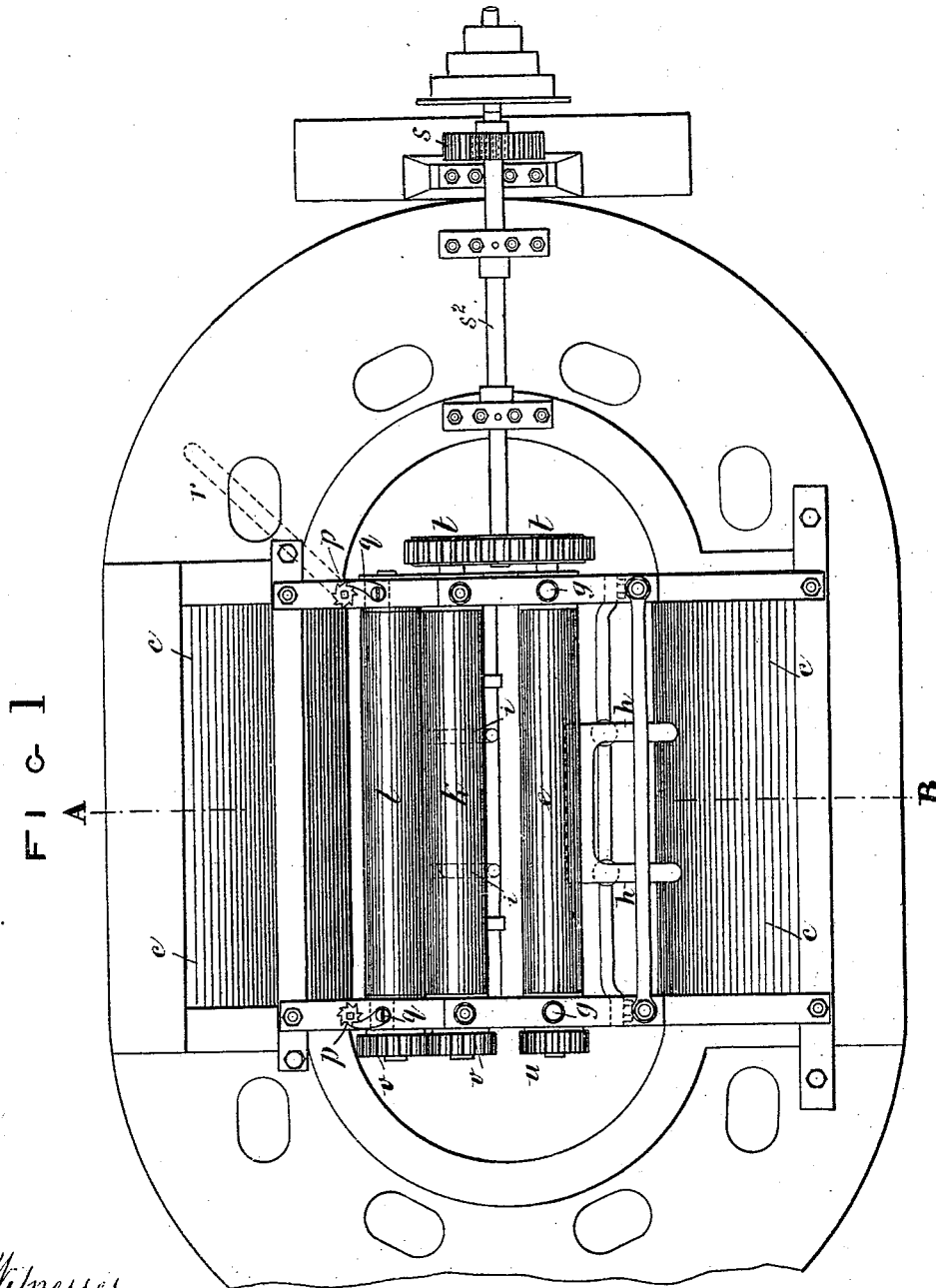

Witnesses
George Shaw
Richard Bennett

Inventor
Richard Heathfield

R. HEATHFIELD.

Coating Sheet-Iron with Zinc or with Alloys of Zinc.

No. 211,905.

Patented Feb. 4, 1879.

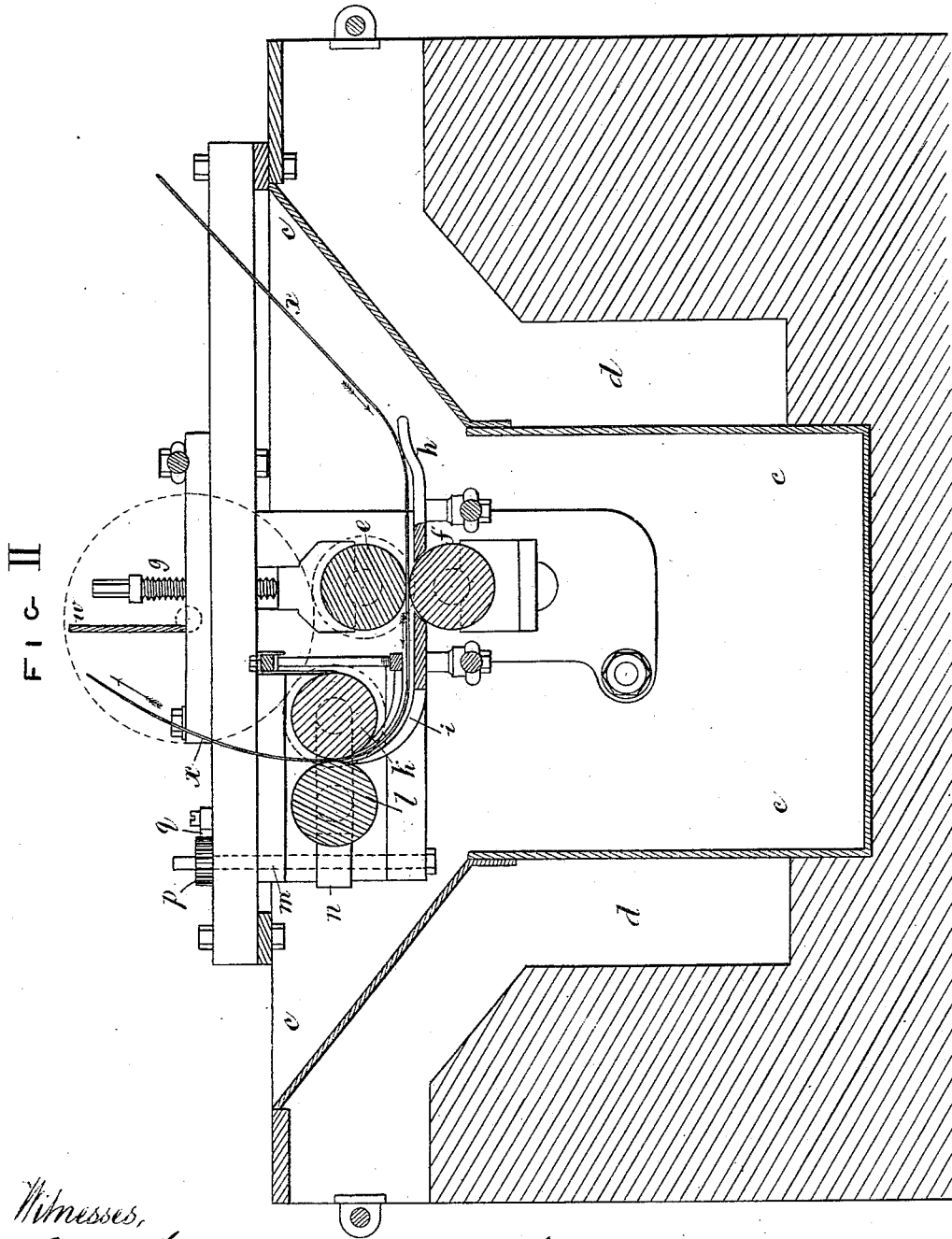

Witnesses,
George Shaw
Richard Skerrett

Inventor
Richard Heathfield

R. HEATHFIELD.

Coating Sheet-Iron with Zinc or with Alloys of Zinc.

No. 211,905.

Patented Feb. 4, 1879.

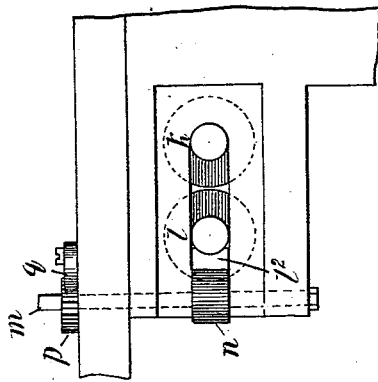

FIG. III

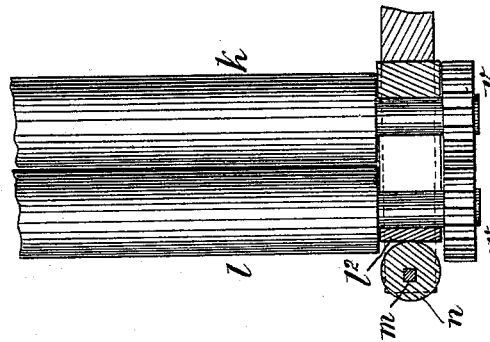

FIG. IV

Witnesses,
George Shaw
Richard Merritt

Inventor
Richard Heathfield

UNITED STATES PATENT OFFICE.

RICHARD HEATHFIELD, OF BIRMINGHAM, ENGLAND.

IMPROVEMENT IN COATING SHEET-IRON WITH ZINC OR WITH ALLOYS OF ZINC.

Specification forming part of Letters Patent No. **211,905**, dated February 4, 1879; application filed October 30, 1878.

To all whom it may concern:

Be it known that I, RICHARD HEATHFIELD, of Birmingham, in the county of Warwick, England, manufacturer, have invented a new and useful improvement or improvements in apparatus or machinery used in galvanizing sheet-iron or coating sheet-iron with zinc or alloys of zinc, which improvements are fully set forth in the following specification, reference being had to the accompanying drawings.

In the ordinary method of galvanizing sheets of iron, the sheets, after having been properly cleaned, are passed through a bath of melted zinc or alloy of zinc, each sheet being either guided to and passed between a pair of plain rolls, or dipped, without the use of rolls, under a bar in the pot, as is well understood. The coated sheet after passing from between the rolls, or under the bar, is guided to the surface of the bath, when it is taken hold of and removed by the tongs of the attendant workman.

My invention consists in placing an additional pair of rolls in the bath of melted metal in the path of the sheet as it passes from the principal or ordinary rolls, whereby the coating of the sheet is much improved.

The axes of the additional pair of rolls are situated in a plain at right angles, or nearly at right angles, to the plane of the ordinary rolls used in galvanizing iron, the said additional rolls being situated a short distance below the surface of the melted metal.

Although in practice I have found that one additional pair of rolls is sufficient for ordinary purposes, yet two or more additional pairs of rolls placed in a plane at right angles, or nearly at right angles, to the plane of the ordinary rolls may be employed where it is deemed desirable.

I will now proceed to describe, with reference to the accompanying drawings, the manner in which my invention may be performed.

Figure 1 represents in plan, and Fig. 2 in transverse vertical section taken on the line A B of Fig. 1, apparatus or machinery to be used in galvanizing sheet-iron, or coating sheet-iron with zinc or alloys of zinc, the said apparatus or machinery containing my inven-

tion. The section Fig. 2 is drawn to a larger scale than Fig. 1.

The same letters of reference indicate the same parts in both figures.

c c is the pot or bath containing the melted zinc or alloy of zinc, the said pot or bath being heated in the ordinary way by the flues *d d*. *e f* is the ordinary plain pair of rolls in the said pot or bath, situated one over the other, the distance between the said rolls *e f* being adjusted by the screws *g g*, acting on the bearings of the upper roll, *e*. *h i* is a guide for guiding the sheet between the ordinary pair of rolls *e f*, and also between the second or additional pair of rolls, *k l*. The axes of the said additional pair of rolls *k l* are situated in a plane at right angles to the plane of the ordinary pair of rolls *e f*, as best seen in the section Fig. 2; but the acting or cylindrical surfaces of the two pairs of rolls, *e f* and *k l*, are situated parallel to one another, as seen in Fig. 1.

The distance between the additional pair of rolls *k l* is adjusted by the following arrangement of parts, best seen in the side elevation, Fig. 3, and plan in Fig. 4: At each end of the rolls *l* is a vertical axis, *m*, carrying at its lower end a cam, *n*, (see Fig. 4,) which presses against the bearing *l*, in which the said roll *l* works. The cam-axis *m* has at its top a ratchet-wheel, *p*, with which a pawl, *q*, on the framing of the pot or bath engages and prevents the back rotation of the said cam-axis. By turning the cam-axes *m m* by means of a lever, *r*, (indicated in dotted lines in Fig. 1,) fitted on the square ends of the said axes, the cams *n n* may be rotated more or less, and the distance of the roll *l* from the roll *k* determined with great nicety, the cam-axes being held in their adjusted positions by the pawls *q q* engaging with the ratchet-wheels *p p*. I do not, however, limit myself to any particular mechanism for adjusting the rolls *k l*, as they may be forced together by levers or other equivalent contrivance instead of by the arrangement of parts shown.

The two pairs of rolls *e f* and *k l* are driven in the manner represented in Fig. 1. A toothed wheel on the driving-shaft gears with the toothed wheel *s* above it. The inner end of

the shaft s^2 of the wheel e carries a large toothed wheel, t , which gears with pinions below it on the axes of the rolls $e k$, respectively. The pair of rolls $e f$ is geared together by the pinions at u , and the pair of rolls $k l$ is geared together by the pinions at v . The additional pair of rolls $k l$ is situated at such a height that the gripe of the rolls—that is, the plane in which the sheet of iron is operated upon by the rolls is situated—is a short distance above or below the surface of the melted metal.

The sheet of iron to be galvanized is passed by the workman to the guide h , and from thence through the ordinary pair of rolls $e f$, by which it is seized and carried through the said rolls to the curved guide i , by which it is guided to the additional pair of rolls $k l$, after passing through which rolls $k l$ the plate is taken hold of and removed by the tongs of the workman.

The manner in which the sheet of iron is passed through the two pairs of rolls $e f$ and $k l$ and the guides $h i$ is represented in Fig. 2, where a sheet in the act of being galvanized is marked x . A vertical stop, w , is fixed in the position represented in Fig. 2 to prevent the sheet of metal returning to the side at which it was introduced should the workman fail to seize it with his tongs as it rises from the pot.

Instead of the single pair of additional rolls $k l$, as represented in the drawings, two or more pairs of rolls, the axes of which are sit-

uated in planes at right angles to the planes in which the axes of the ordinary pair of rolls are situated, may be employed.

By combining one or more additional pairs of rolls with the pair of rolls ordinarily employed, the axes of the said additional rolls being arranged with respect to the axes of the ordinary pair of rolls in the manner hereinbefore described and illustrated, a very uniform and smooth face is given to the coated sheet.

Having now described the nature of my invention and the manner in which the same is to be performed, I wish it to be understood that I claim as my invention—

In an apparatus for galvanizing or coating sheet-iron with metal, the combination, with the basin in which a bath of melted zinc, zinc alloy, or coating metal is maintained, and the pair of submerged rolls ordinarily used, of an additional pair or pairs of rolls, also submerged, and having their axes in planes at right angles to the plane in which the axes of the ordinary rolls lie, and guides arranged relatively, as shown, so that the sheet of iron may pass directly from such ordinary to such additional rolls, substantially as set forth.

RICHARD HEATHFIELD. [L. s.]

Witnesses:

GEORGE SHAW,

RICHARD SKERRETT,

Both of 37 Temple Street, Birmingham.