

T. ROGERS.
Iron Fence.

No. 211,934.

Patented Feb. 4, 1879.

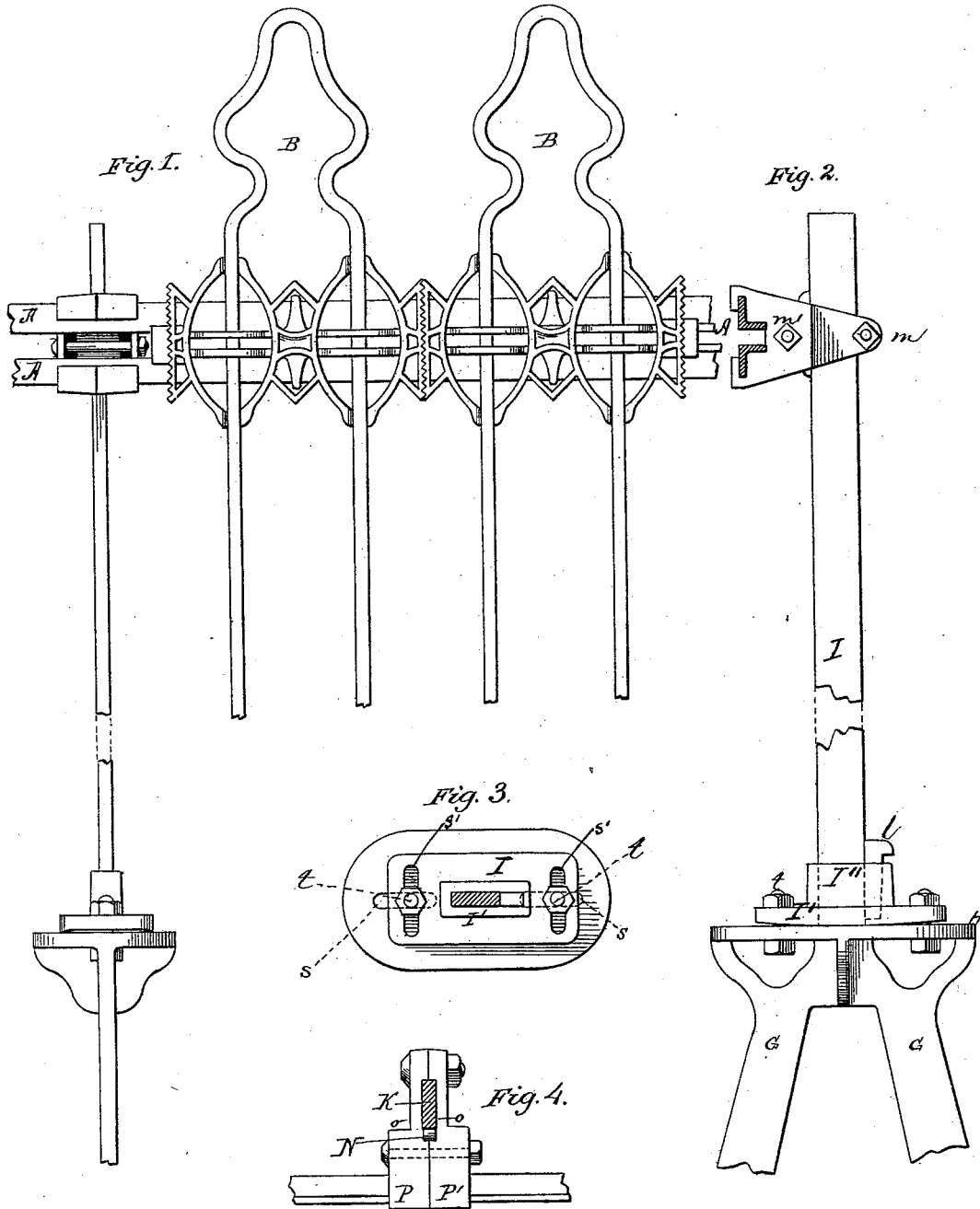

Attest:
 Clarence Pool
 R. K. Evans

Inventor:
 Timothy Rogers
 by A. St. Evans & Co
 Attys

T. ROGERS.
Iron Fence.

No. 211,934.

Patented Feb. 4, 1879.

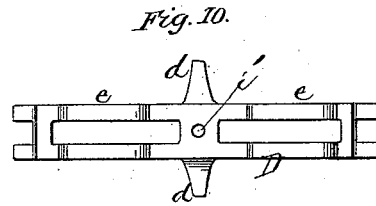
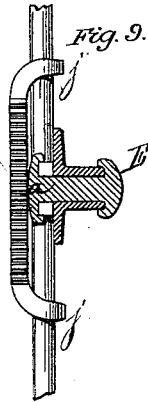
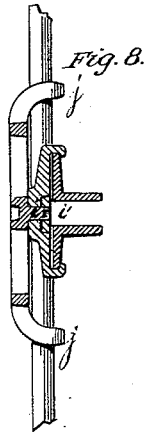
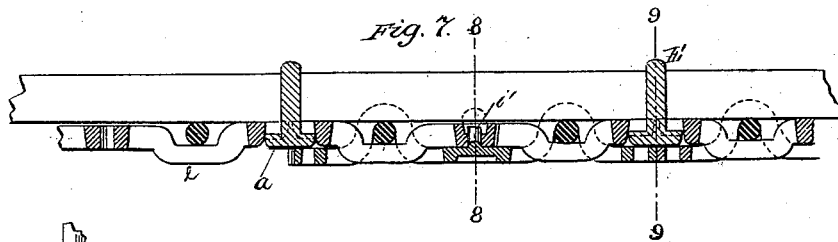
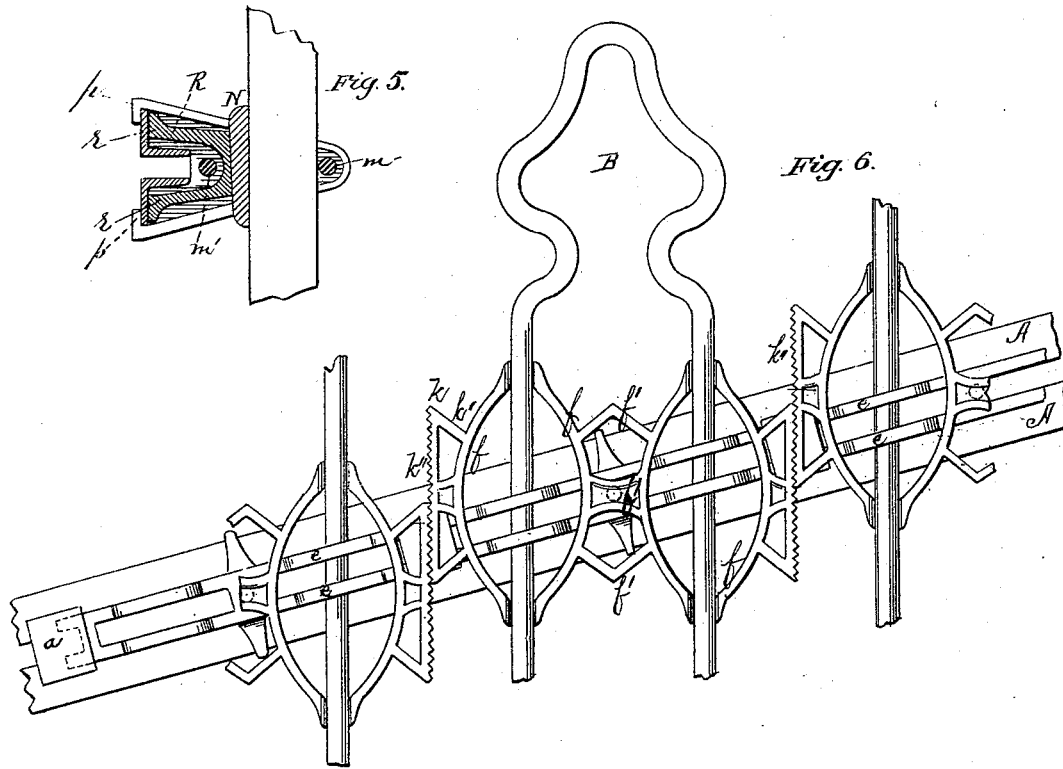

Attest:
 Clarence Poole
 A. K. Evans

Inventor:
 Timothy Rogers
 by A. K. Evans Esq
 Atty.

UNITED STATES PATENT OFFICE

TIMOTHY ROGERS, OF MOUNT VERNON, OHIO, ASSIGNOR OF ONE-HALF HIS RIGHT TO BENJAMIN A. F. GREER, OF SAME PLACE.

IMPROVEMENT IN IRON FENCES.

Specification forming part of Letters Patent No. 211,934, dated February 4, 1879; application filed November 6, 1878.

To all whom it may concern:

Be it known that I, TIMOTHY ROGERS, of Mount Vernon, in the county of Knox and State of Ohio, have invented certain Improvements in Iron Fences; and I hereby declare the following to be a full, clear, and exact description of the same, reference being had to the accompanying drawings, making part of this specification, in which—

Figure 1 is an elevation of the front of the fence. Fig. 2 is a side elevation of the post and the rail in cross-section. Fig. 3 is a plan view of the anchor-plate. Fig. 4 is a plan or top view of clamp of rail to post. Fig. 5 is section of the same. Figs. 6, 7, 8, 9, and 10 are details to be referred to.

The object of my invention is to provide an iron fence the parts of which can be taken to the ground where the fence is to be built and then put together to form panels, and set up so as to conform to the irregularities of the ground; and it consists in a series of adjustable wrought-iron pickets, fastened on bars by means of adjustable fastenings, said bars being supported by means of adjustable posts, and fastened together by means of adjustable fastenings, as hereinafter more fully described and claimed.

In order that those skilled in the art may make and use my invention, I will proceed to describe the exact manner in which I have carried it out.

In the said drawings, A A are two angle-iron bars, supported on vertical posts, and to which the pickets B B, made of bended rods, are attached by means of an ornamental keyed fastening, as hereinafter described.

The picket-clamping devices consist of a series of bars, D, which lie over the pickets and against the bar A, being secured to them by double-headed T-shaped clasps E, the front head, *a*, of the clasp fitting over the ends of bars D, and the rear head, *b*, clasping the rear edges of the angle-iron bars, the shank of the clasp passing between the pieces of angle-iron. At their centers the bars D are provided with lugs *d*, whose ends are upset around the front edges of the angle-iron bars, and between each end of the said bars and the lug *d*

is a curvature, *e e*, so as to leave an elongated opening for the picket-rods to work in.

An ornamental double-ellipse-shaped piece, *f*, having braces *f' f'*, and provided at the tips of the ellipses with depressions *j j*, in which lie the picket-rods, is secured by means of a stud, *i*, in a central opening, *v*, of bar D. The ornamental double-ellipse piece *f* has on each side a straight bar, *k*, supported by arms *k'*, and bearing teeth or serrations *k''*. These serrations interlock with each other at some point regardless of the angle at which the bars A stand.

The ends of each pair of bars D come together beneath the front cap of the clasp E. The pickets being thus secured, the bars D passing over them at *e e*, and the ornaments *f* beneath them at *j j*, they are held firmly between them, and have a rotation around the stud *i* in so far as the elongated opening caused by the bend *e e* will allow the bar to turn, so as to adjust the angle between the picket and bars A A, as shown in Fig. 6.

In the said drawings, G G are the prongs or blades of an anchor, H, to sustain the posts I of the fence, the blades being buried so as to bring the anchor-plate flush with the ground. The anchor-plate H is provided with two central slots, *s s*, cut lengthwise the plate, to receive bolts *t*, to fasten to it a plate, I', bearing a socket, I'', to hold the post-rod I. For the purposes of fastening and adjustment the plate I' has two slots, *s' s'*, at right angles to slots *s s*, to receive bolts *t*. The lower surface of plate I' is slightly curved, as seen in Figs. 1 and 2, so that by the rocking allowed the bar I can be tipped slightly either way for the purpose of vertical adjustment. The square post-bar I is fitted into the socket and secured by a wedge-key, *e*.

The picket-bars are secured to the posts by means of boxes constructed as follows: They are made in two pieces, P P', open in front, as seen in Fig. 5, and provided with flanges *p p*, to fit over the front edges of the angle-iron rails, and at their rear ends with offsets of the general size of the post I, being only somewhat elongated, so as to receive the wedge-key N between the box and the post to tighten

it up when the box is clasped around the posts by bolts *m m'*. Within box *P P'* is a bifurcated bridge-brace, *R*, provided with feet *r r'*. The head of this brace is against the wedge-key *N*, and each one of the feet lies against the vertical web of the angle-iron bar opposite the point where the flanges *p p* clasp them. Driving in the wedge *N* forces the bifurcated bridge forward, and rigidly secures box and bars *A A* to post *I*.

Having thus described my invention, what I claim as new, and desire to secure by Letters Patent, is—

1. The ornament *f*, provided with the stud *i'*, depressions *j j*, and sector-bars *k k*, having teeth *k''*, in combination with an iron fence, substantially as set forth.

2. The ornament *f*, constructed as described, in combination with the bar *D*, provided with

a central opening, *i*, and curvatures *e e*, substantially as described.

3. In an adjustable iron fence, the clasping-bar *D*, provided with bifurcated ends, clasping-curves *e e*, and central projections *d d*, as set forth.

4. The flat-top slotted base or anchor plate *H*, in combination with the rounded socket-plate *I*, provided with the socket *I'*, and post *K*, substantially as described.

5. The clamping-box *P P'*, provided with the inserted brace *R*, in combination with the post *K*, rails *A A*, and key *N*, all constructed as set forth.

TIMOTHY ROGERS.

Witnesses:

BENJ. A. F. GREER,
MAY R. SNOOK.