

W. S. SHOTWELL.
Amalgamator and Settler.

No. 211,939.

Patented Feb. 4, 1879.

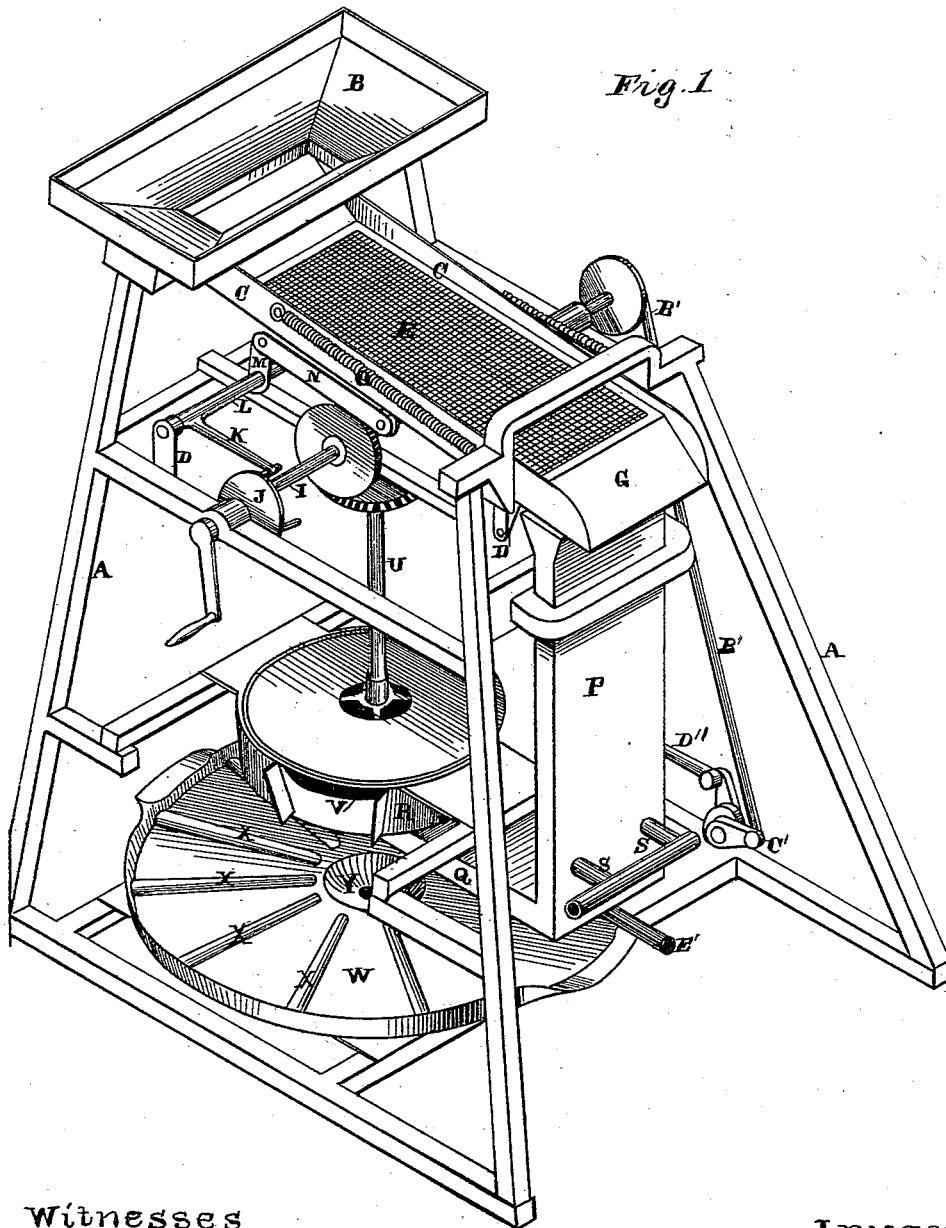

Fig. 1

Witnesses

Geo. Hestrong.
Frank A. Brooks

Inventor

Walter Shotwell
By *Dewey & Co.*
Attys.

W. S. SHOTWELL.
Amalgamator and Settler.

No. 211,939.

Patented Feb. 4, 1879.

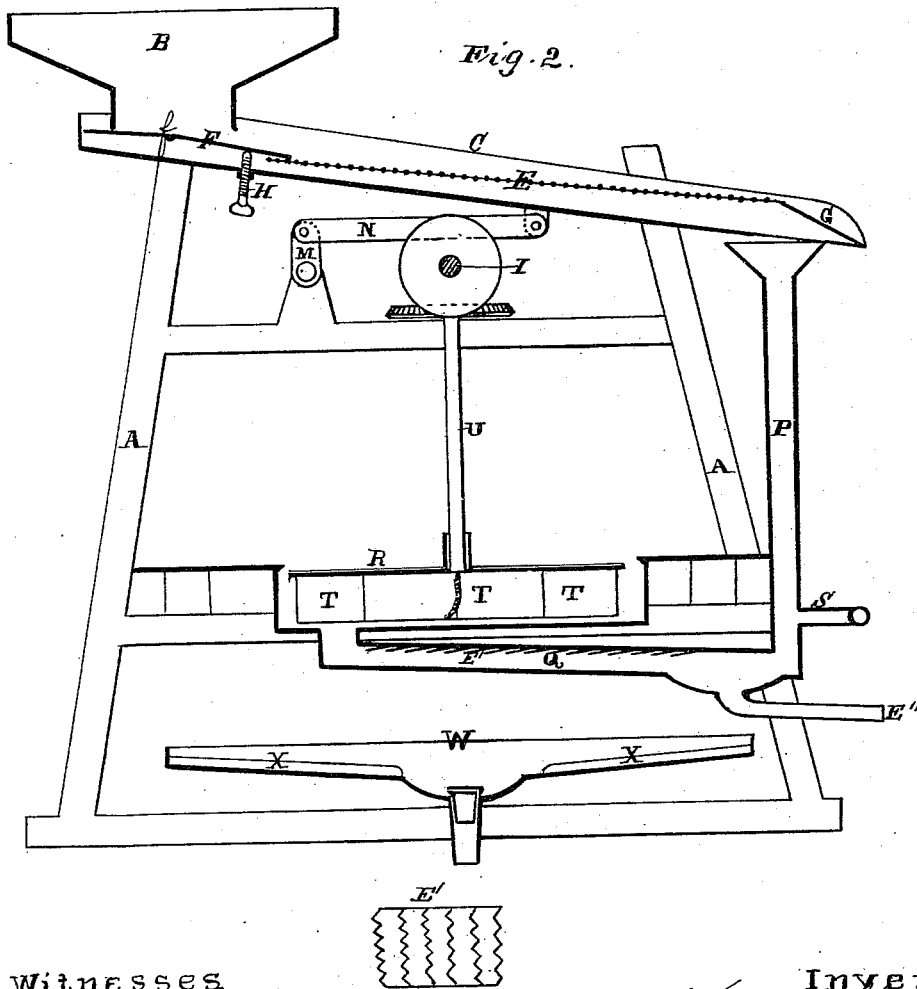

Witnesses
Geo. H. Strong.
Frank A. Brooks

Inventor
Walter S. Shotwell
 By *Dewey & Co.*
 Attys.

UNITED STATES PATENT OFFICE.

WALTER S. SHOTWELL, OF SAN FRANCISCO, CALIFORNIA.

IMPROVEMENT IN AMALGAMATOR AND SETTLER.

Specification forming part of Letters Patent No. 211,939, dated February 4, 1879; application filed August 22, 1878.

To all whom it may concern:

Be it known that I, WALTER S. SHOTWELL, of the city and county of San Francisco, and State of California, have invented an Improved Amalgamator and Settler; and I do hereby declare the following to be a full, clear, and exact description thereof, reference being had to the accompanying drawings.

My invention relates to certain improvements in an apparatus for saving gold and mercury from ores, tailings, sluices, black sand, or other compounds in which they may exist; and it consists in the employment of a shaking table, upon which the material is fed, and from which it escapes into a vertical passage connecting with a horizontal trunk containing mercury. This trunk is provided with distributing-plates, to thoroughly break up and expose the material to the mercury as it passes. From this trunk the material which has been mixed with water is allowed to escape into a vessel with revolving fans or arms, which serve to draw it out and discharge it over the edge into a settling pan or table below. The surfaces are all amalgamated, and the apparatus constitutes an amalgamator and settler.

Referring to the accompanying drawings, Figure 1 is a perspective view of my invention. Fig. 2 is a section of the same.

Let A represent the frame-work on which my apparatus is supported. On top of this frame-work is mounted a hopper, B, under which is suspended an inclined shaking table, C. This shaking table C is suspended on pivoted hanging arms D D', so that it may be oscillated, as hereinafter described. The bottom of this table is formed of plates, over which is stretched a screen, E, the screen extending up under the hinged amalgamated plate F, so that the material passing over this plate F from the hopper will be directed onto this screen.

At the lower end of the screen E is a plate, G, extending from the end of the screen to the end of the shaking table, which directs the material too large to pass through the screen over the end of the table, so that it may be removed.

The plate F is hinged at its upper end to a stationary plate immediately under the opening in the hopper B.

A set-screw, H, passing up through the shaking table, is intended to regulate the inclination or pitch of the hinged plate F, so as to regulate the feed. This is done by moving the set-screw so as to bring the lower edge of the plate F nearer to or farther from the edge of the opening in the hopper, and thus altering the size of the opening between the hopper and plate.

I am aware that it is not new to adjust the opening in the bottom of a hopper by means of a set-screw; nor do I claim such, broadly, as my invention.

A shaft, I, passes across the frame-work under the shaking table, to which power is applied. On this shaft is a wheel, J, having lugs upon it, which engage with an arm, K, attached to the shaft L. On this shaft L are fixed the projections M, to which are hinged the arms N, the other ends of said arms being hinged to the front end of the shaking table.

As the shaft I is rotated the lugs on the wheel engage with the arm K, thus giving a rocking motion to the shaft L. As this shaft is thus rocked the arms N draw the shaking table back, a spring, O, drawing it forward again, thus imparting a shaking motion to the table.

The fine material passing through the screen on the shaking table falls onto the plates, and runs over the lower end of these plates into the vertical passage P. This passage connects with a horizontal trunk, Q, which has a quantity of mercury placed in it, and through which the material must pass. The trunk Q is inclined, as shown, and at its upper end is connected with the bottom of a vessel or separator, R, into which the material is directed by force of gravity. To prevent material from packing in the passage or trunk, streams of water are directed into the lower end of the passage through the pipes S, which stir the material up and assist in forcing it through the mercury in the trunk. The upper face of this trunk is composed of a series of riffles, E', having serrated edges, as shown. These riffles serve to break up lumps of pulp, and also prevent the pulp from packing in the trunk.

As the material rises in the inclined trunks it passes into the separator R, which has a revolving top, the lower side of which is pro-

vided with fans or arms T. This top is rotated by the vertical shaft U, connected by gear and pinion with the horizontal driving-shaft I, as shown. It is so arranged that the top is simply slipped upon the shaft when it is desired to clean up or get at the fans, and when it drops down it is in place for being revolved by the shaft. The top of this separating-vessel being rapidly rotated, the arms or fans stir up the material; and these fans being formed of amalgamated plates, while the interior of the vessel is itself also amalgamated; any particles of gold escaping the action of the mercury in the trunk are here amalgamated, or caught upon the amalgamated surfaces. The fans by their rotation draw the surplus material out over the discharge-openings V in the sides of the vessel, and it falls into the mercury-catcher W below. This vessel R, with its centrifugally-acting arms, separates floured mercury from the sand. The pan or vessel W has ribs or flanges X, radially extending from its center, and a depression or cavity, Y, is formed in the center.

The shaking motion of the pan W, combined with the position of the flanges or ribs, is such as to direct the heavier material—such as mercury or amalgam—to the depression Y, while the tailings pass out over the discharge-opening. An automatic valve, A', in the bottom of the cavity Y, admits of the amalgam and mercury being withdrawn from the pan W without any difficulty, as this valve will be raised when sufficient mercury has accumulated to float it. The surface of the pan W is amalgamated, so as to catch the mercury with greater facility.

A shaking motion is imparted to the pan by a rod, B', attached to a crank or wheel in the outer end of the driving-shaft I. The other end of this rod B' is pivoted on the arm of a bell-crank lever, C', to the other arm of which is pivoted the rod D'', attached to the pan. By this means a shaking motion of the pan is obtained by continuous rotation of the driving-shaft. The pipe E'' is intended for drawing off the mercury or amalgam from the trunk Q when cleaning up the apparatus.

It will be seen that this device will be especially useful in saving gold contained in any kind of material, and more especially where

the gold is in such fine particles as to escape the ordinary methods of amalgamation.

By the means employed the gold is forced through a body of mercury in the trunk, and those particles which have passed through this are beaten and stirred by the fans in the separator, so as to be rubbed and cleaned and finally amalgamated, and the mercury-pan W will catch any particles of amalgam washed over the pan by the stirring process. The screen allows only material of a certain size to pass into the passage and trunk, while the larger pieces are screened off immediately.

The device is simple in operation, and does not require a great amount of power to drive it. The arrangements for cleaning up are such that very little time or labor is required for that operation.

I am aware that a vertical feed-pipe, horizontal mercury-chamber, and separating-chamber with rotary arms, when combined in an amalgamator, are not new.

Having thus described my invention, what I claim, and desire to secure by Letters Patent, is—

1. The inclined oscillating table C, provided at its upper end with a plate, F, hinged at f, in combination with the hopper B, and set-screw H, said plate F being located beneath the discharge of the hopper and controlling the size of the opening, as described.

2. The mercury-trunk Q, with its feed and discharge pipes, and the water-supply pipe S, and provided with the serrated distributing-plates or riffles E', in combination with the separator R, with its rotating arms T, and the settler W, substantially as and for the purpose herein described.

3. The inclined shaking table C and screen E, suspended by the hangers or links D D', in combination with the shaft L, arms K and M, links N, and the rotating driving-shaft I, with its wheel and lugs J and the retracting-spring O, substantially as and for the purpose herein described.

In witness whereof I have hereunto set my hand.

WALTER S. SHOTWELL.

Witnesses:

GEO. H. STRONG,
FRANK A. BROOKS.