

S. J. ADAMS.  
Molding Tubular Article.

No. 211,951.

Patented Feb. 4, 1879.

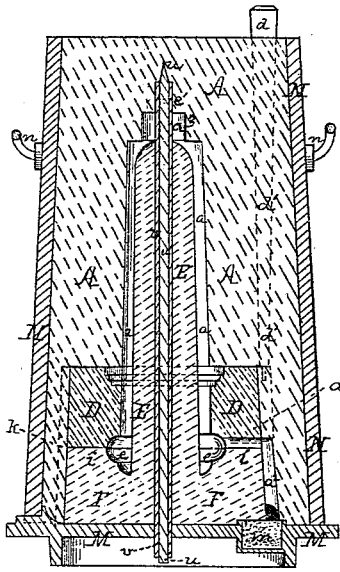

Fig. 1.

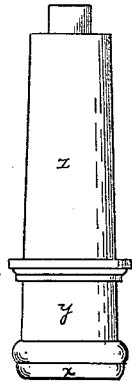

Fig. 2.

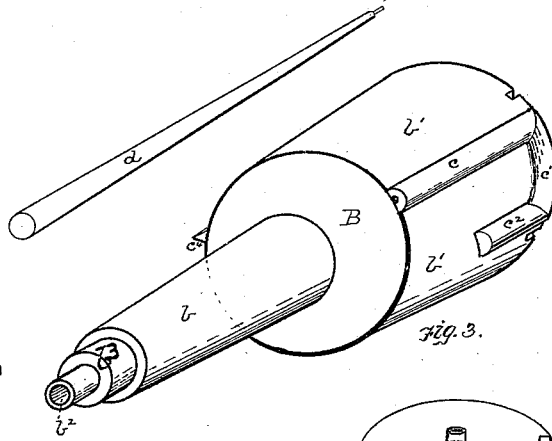

Fig. 3.

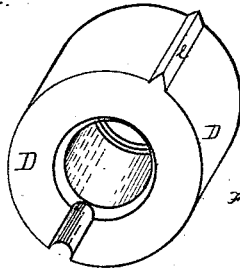

Fig. 4.

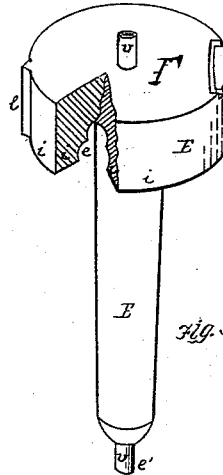

Fig. 5.

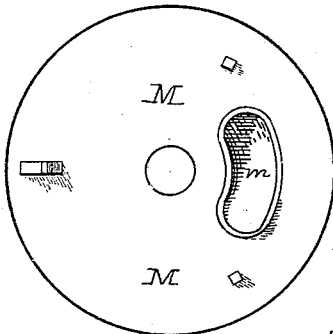

Fig. 8.

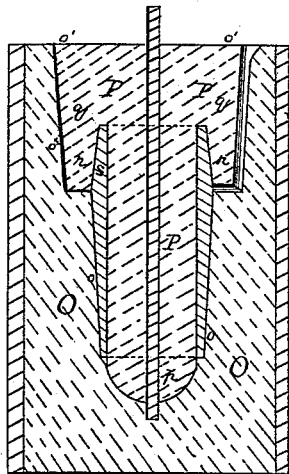

Fig. 6.

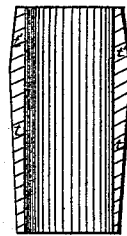

Fig. 7.

Witnesses.

*M. A. Wood*  
*Theo. F. Anthony*

Inventor

*S. Jarvis Adams*  
*by James L. Bray*  
*his Attorney*

# UNITED STATES PATENT OFFICE

S. JARVIS ADAMS, OF PITTSBURG, PENNSYLVANIA.

## IMPROVEMENT IN MOLDING TUBULAR ARTICLES.

Specification forming part of Letters Patent No. **211,951**, dated February 4, 1879; application filed April 5, 1878.

*To all whom it may concern:*

Be it known that I, S. JARVIS ADAMS, of Pittsburg, in the county of Allegheny and State of Pennsylvania, have invented a new and useful Improvement in the Manufacture of Tubular Articles; and I do hereby declare the following to be a full, clear, and exact description thereof, reference being had to the accompanying drawings, forming a part of this specification, in which—

Figure 1 is a sectional view of a mold for forming wagon-skeins, illustrating my invention. Fig. 2 is a view of the wagon-skein formed in said mold. Fig. 3 is a view of the pattern for forming the mold. Fig. 4 is a view of the ring-core. Fig. 5 is a view of the core proper. Fig. 6 is a sectional view of a mold for forming wagon-boxes. Fig. 7 is a view of the wagon-box formed therein, and Fig. 8 is a top view of the bottom plate.

Like letters of reference indicate like parts in each.

My invention relates to molds and cores for forming tubular and other hollow castings, especially those of a bilged shape, or having upon their outer surface "raises," rings, or lugs, which extend from the surface thereof.

In casting some articles of the class referred to, the flask has been formed in two parts, divided longitudinally, and after the formation of the mold the cope was lifted off, the core laid in the drag horizontally, and the cope replaced, being guided to its place by dowel-pins on the flask. If the dowel-pins became loose, one part of the mold would slip on the other, or not fit exactly into place, and thus form fins or irregularities in the casting. Also, in the manufacture of thimble-skeins and other articles where the sanded rod passing through the core formed the bearing at one end, the core was liable to rise and float on the molten metal, and press out of its seat, more or less, causing uneven thickness of shell or weak imperfect castings. For these and other reasons it has been found desirable to use vertical flasks for this kind of work, the articles being cast vertically and the flask divided horizontally wherever there was a raise or ring on the casting, the pattern being also divided wherever these raises came, so as to be re-

moved from the mold. After the pattern was removed the different parts of the flask were placed together, being guided to position by dowel-pins, and the core was placed in the mold. This method, though generally making more perfect castings, was objectionable, for the following reasons: As the casting was heavy a flask was required for each casting, and each shape of casting required a special flask, making it very expensive. On account of the dampness of the sand, the hot metal would generate steam, which, in escaping, would cause the wooden flask to swell and get out of shape, making it necessary to adjust the dowel-pins when the flask was next used, thereby losing much time, and the flask would in time become loose and rickety; also, if one of the parts of the flask was rammed harder than the other, it would cause the flask to spring out of shape and disarrange the dowel-pins, thus causing irregular castings.

The object of my invention is to overcome these difficulties in forming bilged and similar shaped tubular casings, by means of molds and cores which can be cheaply and accurately formed and easily adjusted to position.

My invention consists in certain improvements in molds and cores of such construction that the cores fit or center themselves in the mold, so as to enable me to form molds for bilged and like shaped tubular castings in single or solid molds, as hereinafter more particularly described.

It also consists in certain details of construction, hereinafter more specifically set forth.

To enable others skilled in the art to make and use my invention, I will describe its construction and manner of use.

In the drawings referred to, Figure 1 illustrates my invention applied to the manufacture of wagon-boxes and skeins, in which A represents the vertical mold, formed in a single or solid flask, said mold being formed by the pattern B, in the usual or any known method. The part *a* of the mold (in which is molded the part *z* of the box down to the first ring on the casting) is formed by the part *b* of the pattern B. The head *b* of the pattern forms an enlarged cavity in the mold, communicating with

the cavity  $a$ , which enlarged cavity (when the mold is in position for casting) is beneath and surrounded by the sand of the cope part. On the side of said pattern are the lugs  $c$   $c^1$   $c^2$ , for forming the pouring-gate  $a^2$  to the mold, and in a socket in the top of said lug  $c$  fits the rod or sprue-pattern  $d$ , which extends to the top of the mold, and forms the pouring-hole  $d'$  thereto, as hereinafter described. Upon the other side of the head  $b^1$  is another lug,  $c^4$ , which forms the longitudinal guiding-recess  $k$  in the cavity  $a^1$ . After the formation of the mold the sprue  $d$  is drawn from above, and the mold is turned over.

The pattern B is provided with the cylindrical passage  $b^2$ , extending longitudinally through the same, through which the guiding-rod  $u$  is passed, after the sand has been packed, until it is embedded in the sand of the mold. It will be readily seen from an examination of the drawings that this rod  $u$  is supported at or near both ends in a central position relative to the mold by means of the pattern, and that the end of the rod which projects from the lower end,  $b^3$ , of the pattern is surrounded by tightly-packed sand.

As the original pattern B is either straight or tapering, it can be easily drawn from the mold, and the rod  $u$ , remaining in the mold, acts as a guide to prevent its marring the sides of the mold when being removed. Thus this rod is adapted to serve not only as a guide to facilitate the withdrawal of the pattern without injuring the mold, but also to guide to its place the core, to be hereinafter described. This rod  $u$  is only necessary in forming large molds.

Fitting and centering in the cavity formed by the head  $b^1$  of the pattern is the mold-ring D, of such inner shape that it forms the part  $y$  of the skein, leaving the annular cavity between it and the mold in which the ring on the skein is formed. The ring D extends to the next lug or projection on the casting, and, if necessary, part way up the same.

E is the core, provided with the core-print  $e'$ , formed by the tube  $v$ . To the core E is attached the drag part F of the mold, which fits and centers itself in the cavity formed by the head  $b^1$  of the pattern.

The drag part F is provided with the annular return  $i$ , forming the annular cavity or rabbet  $e$  in the core, in which rabbet the upper part,  $x$ , of the wagon-skein is cast, the enlargement in the casting being formed between the ring-core and core proper.

The mold-ring and core proper are formed in core-boxes of the desired shapes by the usual or any known method, and may be baked or dried.

The outer surfaces of ring D and drag part F are of such shape as to fit neatly into the cope-cavity of the mold, and are preferably made tapering, so as to slide into the exact position required.

If the casting requires it, two or more ring-cores may be used, and in some cases the ring-

cores may be made in sections to form any particular shapes. If the cope-cavity is square or oblong, the said cores, being of the same exterior shape, fit into the cavity in the right position. When the cope-cavity is cylindrical the said cores are guided to their proper relative position by the lugs  $l$  fitting into the recess  $k$ , above referred to.

In forming heavy castings, such as large wagon-boxes, instead of the usual sanded wire passing through the core, I use the tube  $v$ , and by passing the tube over the guiding-rod  $u$  in the mold direct the core to its place without touching the mold or forming imperfections therein. The guiding-rod  $u$  may then be withdrawn from the mold.

M is the bottom plate, which is preferably made of metal, and has formed in it the recess  $m$ , around which is the raised rib or bead. The recess  $m$  is formed on the part of the plate under the pouring-gate  $a^2$ , and is filled and packed with sand, and when placed on the mold forms with the mold part of the pouring-gate. The metal falling from the top of the mold would cut or score out the metal bottom plate and wear it away; but as the sand can easily be replaced, it has no injurious effect on the plate. The raised rib or bead around the recess presses into the mold and precludes the leaking of the metal. The metal passes through the cope part A, and along the outer face of the mold-ring D and drag part F, and drops upon plate M, and rises up again through the pouring-gate  $a^2$ , and passes between the mold-ring D and drag F, as shown. By entering from the bottom of the mold the metal rises gradually in the mold, and there is no danger of its cutting into the sides of the mold or core, as it would naturally do if it dropped from the top. After the mold is formed and the mold-ring and the drag are set in position, the bottom plate, M, is placed thereon, the mold inverted, the flask removed, and the finished mold is carried to its place on the floor. As the mold rests on and surrounds the core, it acts as a weight to hold it in position, and prevents its being moved out of place by the molten metal.

N represents the removable weight used when the metal is poured to the molds. This weight N is of the same interior shape as the exterior of the mold and slightly shorter, so that it may be pressed down tight on the mold. It is provided with the handles  $n$ , by means of which it is lifted from one mold to another. After the mold is formed with the pattern B, the sprue  $d$  is withdrawn, the mold is inverted, the rod  $u$  is pressed through the tube  $b^2$ , and the pattern is withdrawn. The mold-ring D and core E are then placed in the mold, the bottom plate, M, is placed thereon so that the recess  $m$ , filled with sand, is over the pouring-gate  $a^2$ , the mold is inverted and the flask is removed, and the mold is ready for casting. Before pouring, the removable weight is placed on the mold, and after pouring the weight may be removed and used for another mold.

In Fig. 6 is illustrated my invention as applied to the manufacture of wagon-boxes and like articles where there is but one bilge or raise in the casting. The mold O is formed in the manner above described, having the cylindrical part *o* extending to the apex of the bilge and the cope-cavity *o'* above. The core P is formed with the core-print *p* at the base, and the cope *q* fitting into the cope-cavity *o'*.

The annular return *r* of the cope extends down to the apex of the bilge, forming, with the core the annular rabbet or cavity *s*. The lower part, *t*, of the casting shown in Fig. 7 is formed in the part *o* of the mold, and the upper part, *t'*, in the rabbet or cavity *s* of the core. If desired, the return *r* may be made in the form of a ring, and the core formed without any return. The metal may be poured between the mold and core, as shown, in which case the pouring-hole may be formed by a large lug on the pattern.

Among the advantages of my improvement are the following:

I am enabled to form tubular and other hollow castings of bilged and similar shapes in upright, single, or solid molds, which were only used heretofore for articles having a straight taper, which could be plainly drawn from the mold endwise.

As a single or solid flask is used, one shape of flask will serve for many different shapes of castings, thus doing away with a large expense in the manufacture of these articles; and by getting up a new set of patterns, which in this case is not expensive, a new form can easily be cast in the same flask.

As there are no dowel-pins used on the flask, no time is lost in adjusting them to place, and no difficulty encountered on account of their springing from any cause.

Where the flask is used on the mold while pouring, the swelling of the flask by the steam generated does not affect the casting in the least, as the relative positions of core and mold are not dependent thereon.

As the rings and cores center themselves in the mold, the casting can always be formed of uniform thickness, and there is no danger of the parts slipping and getting out of place.

The molds can be easily and rapidly formed, and the core-rings and cores can be rapidly formed, and seat themselves in the molds.

By forming the annular return in the core I dispense with one division of the flask, or with one ring-core, in my improved mold.

As the mold rests upon and surrounds the cores, no weight is necessary to hold the cores in place.

The removable weight surrounding the molds enables me to dispense with the flasks, the one used in forming the molds being the only one needed.

What I claim as my invention, and desire to secure by Letters Patent, is—

1. The pattern B, having the enlarged head *b'*, upon whose outer face is a rib or projection, for forming the pouring-gate to the mold, substantially as set forth.

2. The method of withdrawing a pattern from or inserting a core into a sand-mold—namely, by centering a guide-rod in the mold-box, by means of the pattern, driving the end of the rod into the packed sand to sustain rod, and thereafter sliding either the pattern or the core upon the rod, substantially as set forth.

3. In devices for casting tubular articles, a vertical mold provided with an enlarged cavity, communicating with the core-cavity, in combination with a mold-ring fitting in and centering in said mold, substantially as set forth.

4. In combination with a vertical mold having an enlarged cavity formed in the sand at its lower end, a mold-ring and a drag which center themselves in said mold, substantially as set forth.

5. The vertical mold provided with an enlarged cavity and a guide-recess, *k*, in combination with the mold-ring D, fitting in said cavity and having a guide-piece, substantially as set forth.

6. In a vertical mold, a cope provided with an enlarged cavity and a guide-recess, in combination with a drag adapted to fit in said cavity, and provided with a guide-piece, substantially as set forth.

7. In a mold, the combination of the following elements: a cope having an enlarged cavity below the core-cavity, a drag centering itself in said cavity in the cope, a core attached to the drag, and prevented from floating by the weight of the cope, and a supporting-board contiguous to the lower ends of both cope and drag, substantially as set forth.

8. The guide-rod *u*, embedded in the sand of the cope, and extending through the bottom board, for guiding the pattern and the core, substantially as set forth.

9. In combination with the core E, the tube *v*, embedded in the sand, and extending through the bottom board, substantially as set forth.

10. To form a pouring-gate, the combination of the pattern B, provided with the projection *c*, with the sprue-plug *d*, fitting into a socket in said projection, substantially as set forth.

11. In a mold for tubular articles, a cope provided with a longitudinal guiding-recess, in combination with a core provided with a guide adapted to engage with said recess, substantially as set forth.

In testimony whereof I, the said S. JARVIS ADAMS, have hereunto set my hand.

S. JARVIS ADAMS.

Witnesses:

JAMES I. KAY,  
R. J. McCLURE.