

T. BOWMAN.  
Grinding Mill.

No. 211,964.

Patented Feb. 4, 1879.

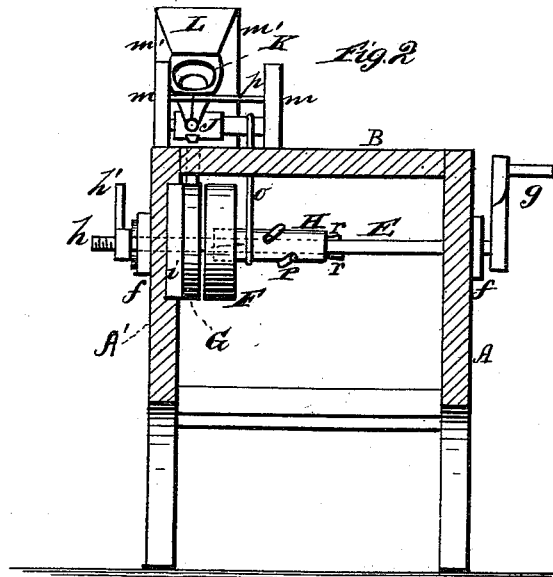
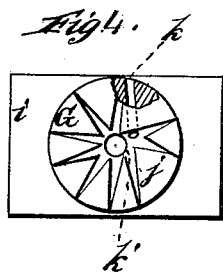
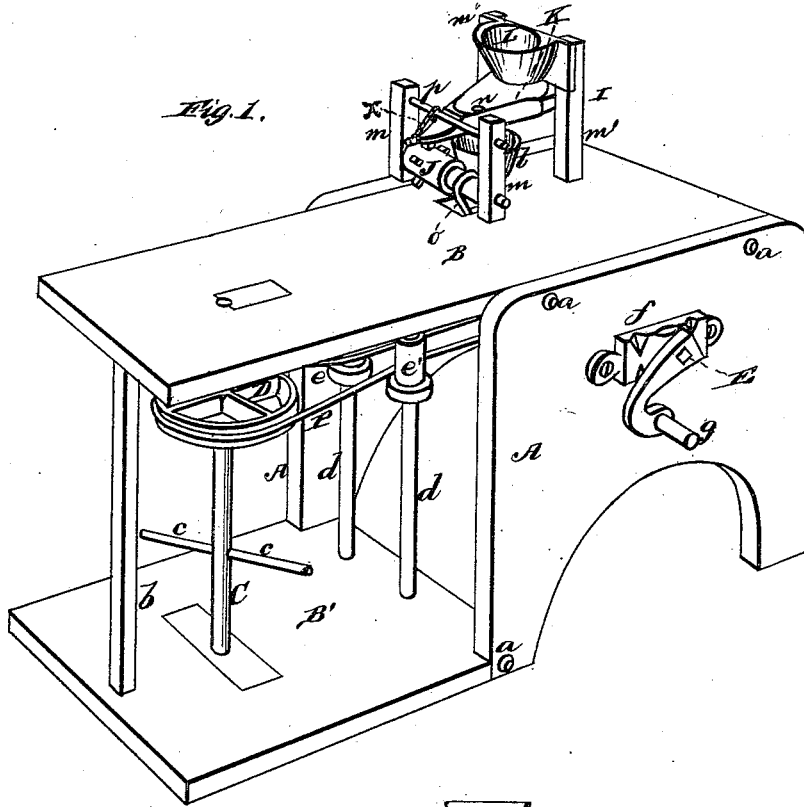

WITNESSES  
*Robert Everett*  
*James J. Sheehy*

INVENTOR.  
*T. Bowman*  
 By *Gilmore, Swisher & Co.*  
 ATTORNEYS

T. BOWMAN.  
Grinding Mill.

No. 211,964.

Patented Feb. 4, 1879.

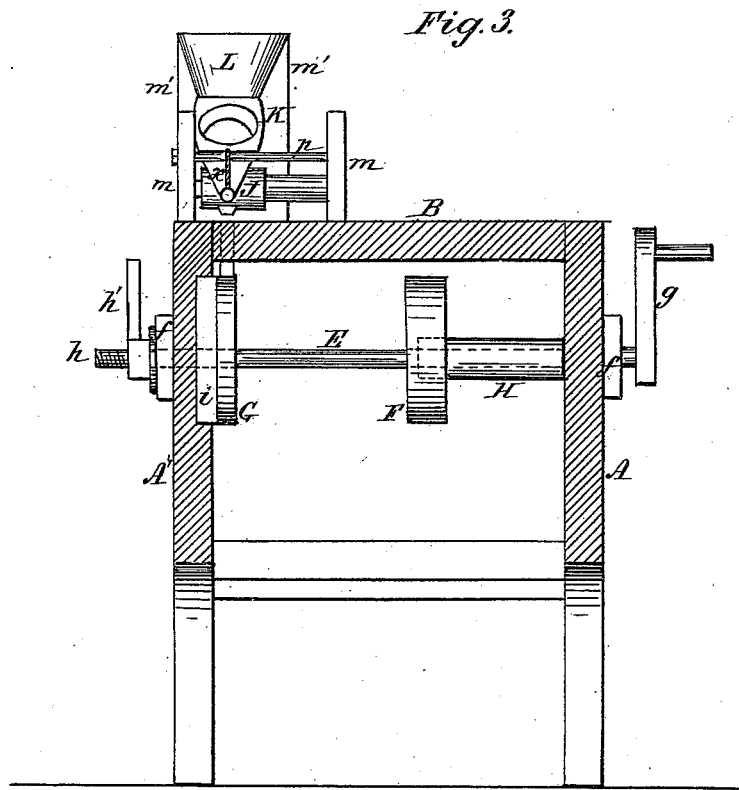

*Witnesses:*

*D. Lloyd Harris*

*D. P. Cowl*

*Inventor:*

*Teman Bowman*

*by Johnson & Johnson*  
*Atty.*

# UNITED STATES PATENT OFFICE.

TEMAN BOWMAN, OF ALUM WELLS, VIRGINIA.

## IMPROVEMENT IN GRINDING-MILLS.

Specification forming part of Letters Patent No. **211,964**, dated February 4, 1879; application filed August 17, 1878.

*To all whom it may concern:*

Be it known that I, TEMAN BOWMAN, of Alum Wells, in the county of Washington and State of Virginia, have invented a new and valuable Improvement in Grinding-Mills; and I do hereby declare that the following is a full, clear, and exact description of the construction and operation of the same, reference being had to the annexed drawings, making a part of this specification, and to the letters and figures of reference marked thereon.

I have improved the portable mill for grinding flour in which the grinding-burrs are adapted to work in vertical positions.

My improvement especially consists in mounting the runner-stone upon its carrying-shaft by a sleeve adapted to be keyed thereto and to be moved thereon to carry the runner away from the stationary burr a sufficient distance to allow free access to their grinding-faces for dressing, when required, without removing them from their positions in relation to said shaft or disturbing their axial relations, and by this means avoid the inconvenience and labor incident to taking the mill to pieces when the stones are required to be dressed, which is an important matter in mills adapted for operation as a portable article. For this purpose the sleeve is made sufficiently long to give a firm and true bearing for the runner upon the carrying-shaft, and the latter is of such length between its bearings as to afford an unobstructed way and allow the runner and its sleeve to be moved upon said shaft away from the stationary burr by simply removing the securing-key or other equivalent removable fastening, so that a person can readily work with the dressing-tools in the space between the two burrs and dress them.

In this operation it will be seen a corollary convenience and advantage is afforded by turning the runner upon the shaft if it is found easier to work at the lower part of the stone.

When the burrs are dressed, the runner is slid back in grinding position and secured to its shaft.

By this construction it only needs that the burrs be properly set to work true, and the subsequent dressing operation will not disturb such adjustment, because their relation to the shaft remains unchanged, whether they be in

working position or separated for the purpose stated.

Referring to the drawings, Figure 1 represents a view, in perspective, of my improved grinding-mill. Fig. 2 shows the burrs as adjusted in working position; Fig. 3, the burrs as separated for being dressed without disturbing their axial relation to each other; and Fig. 4, a face view of the stationary burr.

The shaft E of the grinding-burrs is mounted in proper bearings *f f* in a suitable frame, A A', so that the burrs F and G work in vertical positions in relation to said shaft. The stationary burr G is permanently secured by a base, *i*, in any suitable manner to the vertical inner side of one side of the frame, with the shaft E passing centrally through said burr and turning independent of it. It has any proper dress, *j*, and a passage, *k*, leads from its periphery to a face-opening, *k'*, near its center, as shown in Fig. 4, through which the grain is fed to the grinding-surfaces.

The runner F is fixed upon the square end of a sleeve, H, which is mounted upon the shaft E, to which it is secured by keys *r* when the burrs are properly set for operation. The sleeve is of a length to give a good and true bearing upon the shaft E, while the latter is long enough to give a clear way between its bearings to allow the runner and its sleeve to be moved upon said shaft away from the stationary burr to give free access between the burrs, and thereby very great convenience for easily getting at and dressing them without removing them from the shaft or disturbing their axial relation thereto. This is done by removing the wedge-keys *r* and sliding the runner back upon the shaft out of the way. In dressing the runner it may be turned upon said shaft if it is found easier to work at the lower portion of the burr.

When once set, the adaptation of the runner for removal in the way described does not affect its true adjustment with the face of the stationary burr. This is a highly-important matter in a portable mill, and gives very material advantages in preserving the working condition of the mill.

The runner is adjusted to grind fine or coarse by a screw, *h*, and nut *h'* on the end of the shaft E, as may be desired. The other end of

the shaft E has a crank-handle, *g*, by which to operate the mill. Upon the top B of the frame a hopper, L, and shoe K are arranged between studs *m' m'* to receive and conduct the grain into a supplemental hopper, *l*, from which it passes into the passage *k* of the burr G, through the face-opening *k'*, to the grinding-surfaces. The shoe is agitated by a toothed roll, J, supported between studs *m m*, and driven by a belt, *o*, leading from the sleeve H, and the toe of the shoe is connected by a cord, *x*, to a rod, *p*, by which the shoe may be adjusted to give more or less feed, as may be required.

The mill may be driven by horse-power, the sweep-shaft C *c* of which is supported between the top extension, B, and bottom, B', and the belt P from the pulley D leads to the sleeve E, and is supported by friction-rolls *e e* upon spindles *d d*. The horse-power appurtenances may be dispensed with, if desired.

The agitator-belt *o* and the belt P are removed when the runner is moved back upon its shaft, and this and the removal of the sleeve-fastening are the only changes required to allow the runner to be slid away from the fixed burr, as stated.

In adjusting the runner by the nut *h'* the shaft E is drawn in its bearings, so as to bring the keyed runner in proper relation to the fixed burr.

I claim—

In a portable grinding-mill wherein the burrs work in vertical positions, the sleeve H, united to the runner F, and adapted to be moved away from the stationary burr G upon a carrying-shaft, E, of sufficient length to form a guideway for said sleeve and to leave a clear way between the burrs for dressing, in combination with the keys *r*, or equivalent fastenings for said sleeve, and the adjusting device *h h'* for said shaft, all constructed and adapted for operation substantially as herein set forth.

In testimony that I claim the above I have hereunto subscribed my name in the presence of two witnesses.

TEMAN BOWMAN.

Witnesses:

WESLEY PRICE,  
FREDRIC WHITE.