

M. CARTER & J. F. COPPOCK.
Automatic Gate.

No. 211,969.

Patented Feb. 4, 1879.

Fig. 1.

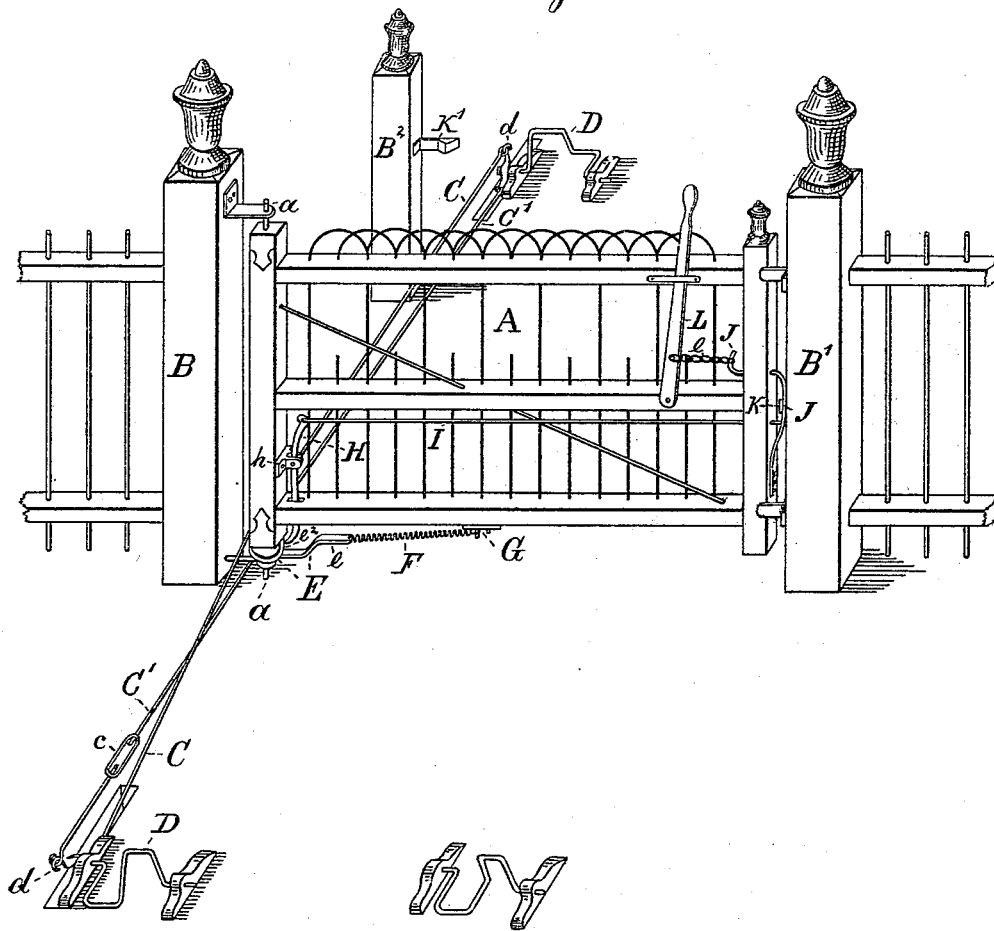

WITNESSES.

James B. Liguier
R. P. Daggett

INVENTORS.

Mordecai Carter,
and John F. Coppock,
PER
C. Bradford
ATTORNEY.

M. CARTER & J. F. COPPOCK.
Automatic Gate.

No. 211,969.

Patented Feb. 4, 1879.

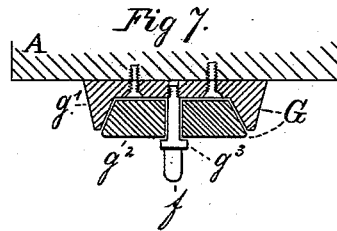
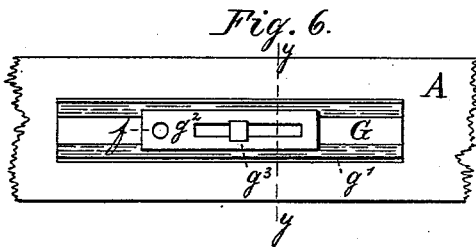
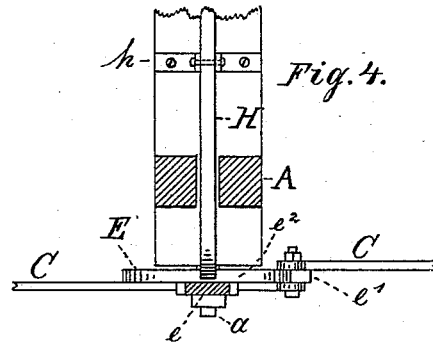
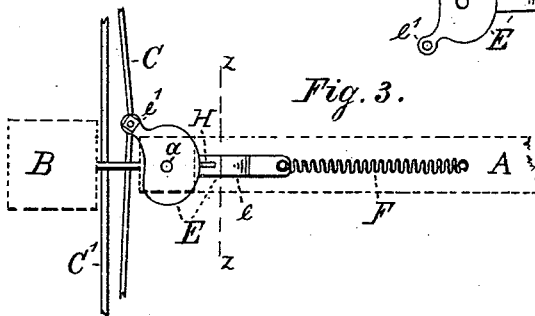
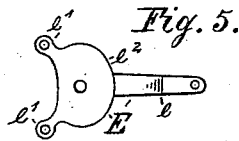
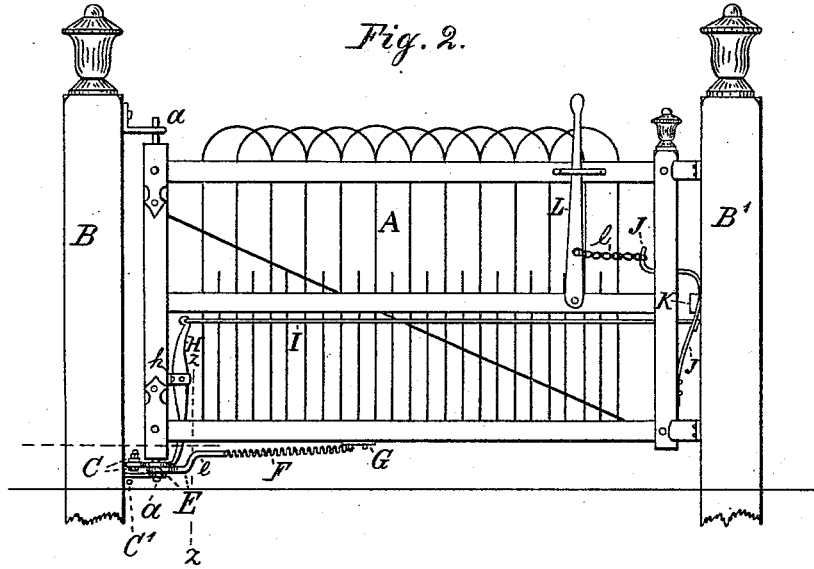

WITNESSES.

James B. Liguier
R. P. Daggett

INVENTORS.

Mordecai Carter,
and John F. Coppock,
PER
C. Bradford.
ATTORNEY.

UNITED STATES PATENT OFFICE.

MORDECAI CARTER, OF PLAINFIELD, AND JOHN F. COPPOCK, OF WEST NEWTON, INDIANA; SAID COPPOCK ASSIGNOR TO SAID CARTER.

IMPROVEMENT IN AUTOMATIC GATES.

Specification forming part of Letters Patent No. **211,969**, dated February 4, 1879; application filed June 10, 1878.

To all whom it may concern:

Be it known that we, MORDECAI CARTER, of the town of Plainfield, county of Hendricks, and State of Indiana, and JOHN F. COPPOCK, of the town of West Newton, county of Marion, and same State, have invented certain new and useful Improvements in Automatic Gates, of which the following is a specification:

This invention consists, for the most part, of improvements upon that for which Letters Patent of the United States No. 197,599 were granted to one of us, the said Mordecai Carter, bearing date the 27th day of November, 1877, whereby said invention is rendered more exact and certain in its operation and stronger and more durable in its construction.

Reference is had to the accompanying drawings, which are made a part hereof, and on which similar letters of reference indicate similar parts.

Figure 1 is a perspective view of a gate embodying our invention. Fig. 2 is a side elevation thereof. Fig. 3 is a plan view of that portion of the mechanism in the immediate vicinity of the lower hinge of the gate. Fig. 4 is a view from the dotted line *x x* of substantially the same mechanism shown in Fig. 3. Fig. 5 is a plan view of the device E in a form in which it can be used for either a right or left hand gate. Fig. 6 is a plan view of the device G as seen from the under side. Fig. 7 is a transverse section of the device shown in Fig. 6, but in its proper position, as when attached to gate.

Referring to these drawings, the various portions are marked with letters of reference, as specified in the following description.

A is the gate, which may be of any suitable construction. B is the post to which it is hung. B¹ is the post against which it shuts. B² is the post against which it rests when open. C C' are rods by which the power is transmitted from the levers, against which the wheels of the vehicles strike, to the mechanism more directly attached to the gate itself. Of these rods only the first named operates directly, and, should it be made of sufficient size to withstand a pushing as well as a pulling strain, would be the only one necessary to the successful operation of our device. We have,

however, found it much better to use both, which then need only be of a size sufficiently strong to withstand a pulling strain, than to use a single one, which would have to be many times larger in order to possess the requisite stiffness. The rod C is also usually divided at the point where it attaches to the device E, thus securing a flexible joint. We also sometimes use a screw-swivel, *c*, in one or both of these rods, by which to give them the proper tension.

d d are small levers upon the ends of the crank-levers D D, to which to attach the rods C C'.

D D are rods bent in the form of a double crank, thus forming crank-levers, against which the wheels of the vehicles strike, and thus furnish the power by which the mechanism of the gate is operated. They are constructed with one less bend than the ordinary style, (for which see separate illustration on Sheet 1 of drawings,) the central portion running directly from one crank to the other, instead of following the direction of the other parts of the device, and thus forming an angle. The points of superiority which we claim are, that the central portion always forms a brace for the parts against which the wheels strike, thus giving additional strength, and is constructed with less material and labor, thus saving something of the cost.

E is a device to which the rod C is attached, and through which it operates the other mechanism of the gate. It is preferably formed of cast metal, with the arm *e* running parallel with the gate when at rest, and the arm *e*¹ running diagonally toward that side to which the gate swings, these locations giving the greater leverage when the mechanism is in action. The only difference between right and left hand gates is, that the arm *e*¹ is formed on the opposite side of the device; and by making it with two arms, as shown in Fig. 5, it can be used with either indiscriminately.

To the arm *e* is attached the spring F, through which the gate is directly actuated. It also has the cam-face *e*², against which the lower end of the lever H rests, and by which it is operated.

F is a spring, connecting the arm *e* of the

device E to the bottom of the gate, which, when the mechanism is operated, pulls on the gate and forces it open. In case of any obstruction of the gate or disarrangement of the parts, no damage will ensue from attempting to open it, as the flexibility of the spring will permit the levers D to be forced entirely over and all the parts rigidly connected thereto to be operated to the fullest extent without injuring any of them separately, or the gate as a whole. The same flexibility also avoids all danger of a too violent starting of the gate as the vehicle-wheels strike the levers D in ordinary use. A rod might be used instead of the spring, except that the above-described flexibility would be wanting. So far as the ultimate object is concerned—that of opening the gate—we consider the rod and spring to be equivalents, and their operation substantially the same, and would not consider the substitution of a rod for the spring as in any way avoiding our rights; but we regard the spring as superior, for the reason stated, and therefore preferably employ it.

G is an adjustable device by which the tension of the spring is regulated. It consists of two parts, g^1 and g^2 . The part g^1 is permanently attached to the gate, and forms a seat for the part g^2 . The part g^2 has a slot, which allows it to slide backward and forward over the bolt g^3 , which connects the two parts together. On the part g^2 is also the projection f , to which to attach the spring F. The operation of adjusting this device is very simple, and will be easily understood by referring to the drawings.

H is a lever, the lower end of which rests against and is operated by the cam-faced part of the device E, and the top of which is attached to the rod I, through which it operates to release the latch J from the catches K or K'. K is a catch for the latch on the post B¹, and K' is a similar catch on the post B².

L is a lever, connected to the latch J by a small rod or chain, l , by which a person on horseback may unlatch and open the gate without dismounting.

The gate A is preferably hung upon the gudgeons a and a' , though the builder may use any hinge he deems best. The gudgeon a , when used, will also serve as a pivot for the device E.

The operation of our invention may be briefly recapitulated, as follows: The wheel of the vehicle, upon striking the upright part of one of the crank-levers D, forces it down, and thus pulls, by means of its small lever d , the rod C, either directly or through the rod C' and the small lever d at its opposite end. The rod C in its turn draws on the arm e^1 of the device E, moving it partially around, and causing its cam-face e^2 to operate, through the lever H and rod I, to release the latch J. By the time the gate is thus unlatched the arm e has begun to pull with considerable force on the spring F, by which the gate is then immediately started open and given sufficient impetus to cause it to strike the post B², where the latch engages with the catch K'. After passing the gate the wheels of the vehicle strike the other of the levers D, pulling the rod C in the other direction, and closing the gate by substantially the same operation by which it was opened.

Having thus fully described our said invention, what we claim as new, and desire to secure by Letters Patent, is—

1. The combination of the cam e^2 , lever H, and rod I, as a means of operating the latch J, substantially as herein shown and specified.

2. The combination of the levers D, rod C, device E, spring F, adjusting device G, and gate A, substantially as herein shown and specified.

3. As a part of the operating mechanism of a gate, the device E having arms e and e^1 and cam e^2 , substantially as shown and specified.

4. The combination of the levers D, rod C, device E, spring F, and gate A, substantially as herein shown and specified.

5. The combination of the levers D, rod C, device E, spring F, lever H, and rod I, forming the operating mechanism for a gate, substantially as herein shown and specified.

In witness whereof we have hereunto set our hands and seals at Indianapolis, Indiana, this 27th day of May, A. D. 1878.

MORDECAI CARTER. [L. S.]
JOHN F. COPPOCK. [L. S.]

In presence of—

C. BRADFORD,
WM. E. MOORE.