

O. J. DOERTY & P. C. TRITCH.
 Machine for Tenoning Spokes and Boring Felloes.

No. 211,976.

Patented Feb. 4, 1879.

Fig. 1.

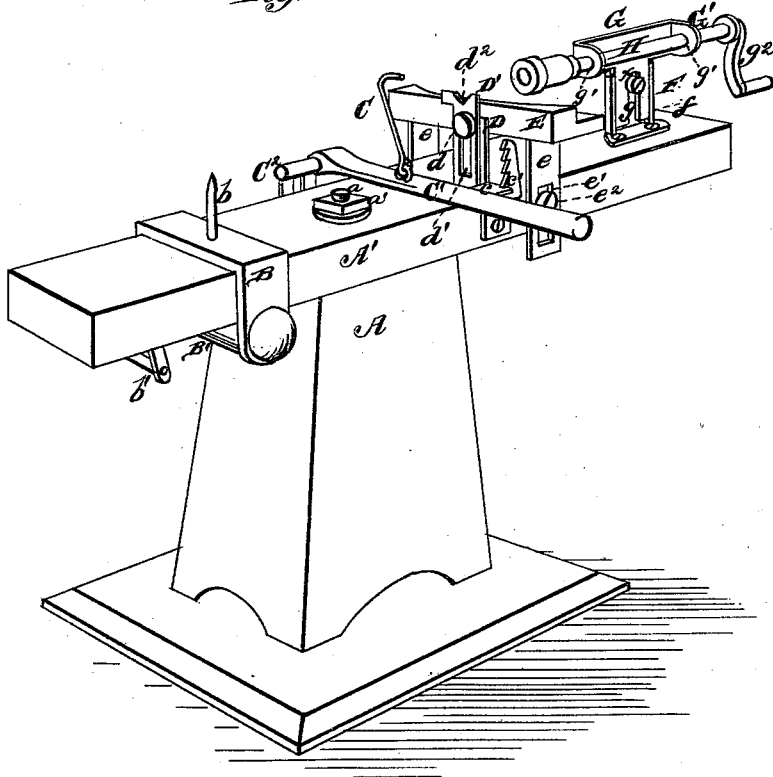
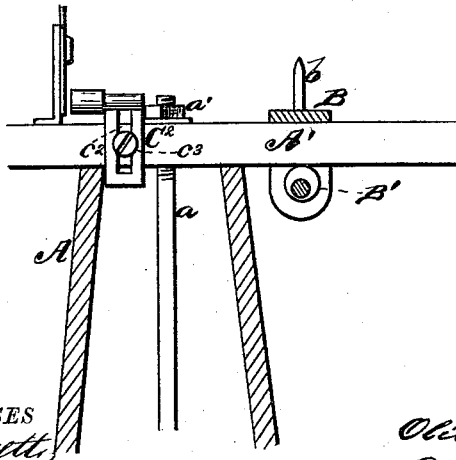

Fig. 2.



WITNESSES
Wm. Sweett
A. J. Smith

INVENTORS
 Oliver J. Doerty.
 Parlee C. Tritch.
 By *Chester. Smith, Co.*
 ATTORNEYS.

UNITED STATES PATENT OFFICE.

OLIVER J. DOERTY AND PARLEE C. TRITCH, OF FINDLAY, OHIO.

IMPROVEMENT IN MACHINES FOR TENONING SPOKES AND BORING FELLIES.

Specification forming part of Letters Patent No. **211,976**, dated February 4, 1879; application filed December 14, 1878.

To all whom it may concern:

Be it known that we, OLIVER J. DOERTY and PARLEE C. TRITCH, of Findlay, in the county of Hancock and State of Ohio, have invented a new and valuable Improvement in Machines for Tenoning Spokes and Boring Fellies; and we do hereby declare that the following is a full, clear, and exact description of the construction and operation of the same, reference being had to the annexed drawings, making a part of this specification, and to the letters and figures of reference marked thereon.

Figure 1 of the drawings is a representation of a perspective of our tenoning and boring machine; and Fig. 2 is a sectional detail view of the same.

Our invention relates to a machine for boring, tenoning, and the like; and the novelty consists in the construction and arrangement of parts, as will be more fully hereinafter set forth.

My invention is especially adapted for forming tenons and mortises on wheel spokes and fellies; but it may be used efficiently for other purposes without departing from the principle of my invention.

The object of the invention is to so construct the parts as to render them adjustable in various ways, and at the same time to have the several parts register with each other.

Referring to the drawings, A represents a suitable frame, upon which is secured a horizontal sill, A'. These parts may be bolted to a suitable base, if desired, or secured to the floor, in any suitable manner, by a threaded rod, a, having nut a', as shown. By this arrangement all slack, &c., may be readily taken up, and the frame kept in a rigid position. B represents an adjustable cap, having a vertical standard, b, which is received into the aperture in the hub, and around which said hub revolves. It is adjustable on the sill A', and may be secured at any desired point by means of cam-bar B', operated by a crank, b'.

In operation the hub is placed on the standard b, and the spokes in the hub may be turned toward the tenoning device at will. To hold the spoke steady with the tenoning device, we employ a hook, C, pivoted to a lever, C', having rack-plate c, which engages with a vertical rack-bar, c', upon the sill A'. This lever is pivoted to a plate, C², having slot c², in which works a set-screw or pin, c³, allow-

ing vertical adjustment of the same upon the sill A'.

D represents a vertical standard, secured to the sill, and having a set-screw, d, which operates within a slot, d¹, in a plate, D'. This plate has a crotch or jaw, d², which is adapted to receive the article to be operated upon, as shown.

e represents two slotted standards, slotted at e¹, which rigidly carry a felly-guide, E, having its concave surface presented toward the lathe. Set-screws e², upon the sides of the sill, operate in the slots e¹, rendering the felly-holder vertically adjustable at will, as is obvious.

F represents a standard, secured to the sill, having guideways f, to receive the standard G, slotted at g, of the bearing G' of the revolving horizontal shaft H. The bearing G' has journals g¹ for said shafts, which may be operated by crank g², or by pulley, or gear with any suitable power. The standard G G' is adjustable vertically by means of a set-screw, x, which operates in the slot g.

The mortising or tenoning implement, of any suitable construction, is placed upon the end of the horizontal shaft H, in any proper manner.

It will be observed that all the devices are adjustable.

We have described the machine as especially adapted to the manufacture of vehicle-wheels; but the device may be applied to any other suitable purpose without departing from the principle of our invention.

The operation of the invention, from the foregoing description, is obvious.

What we claim as new, and desire to secure by Letters Patent, is—

1. The cap B, having standard b, cam-bar B', and crank b', in combination with the sill A' and a lathe, as specified, for the purpose set forth.

2. The standard D d, plate D' d¹ d², in combination with the holding device C C' C² c c¹ c² c³, sill A', and a lathe, as set forth.

In testimony that we claim the above we have hereunto subscribed our names in the presence of two witnesses.

OLIVER JAY DOERTY.
PARLEE C. TRITCH.

Witnesses:

J. C. STRICKLER,
PAUL KEMERER.