

J. HUNSINGER.  
Air-Blast Regulator for Thrashing-Machines, &c.

No. 212,004.

Patented Feb. 4, 1879.

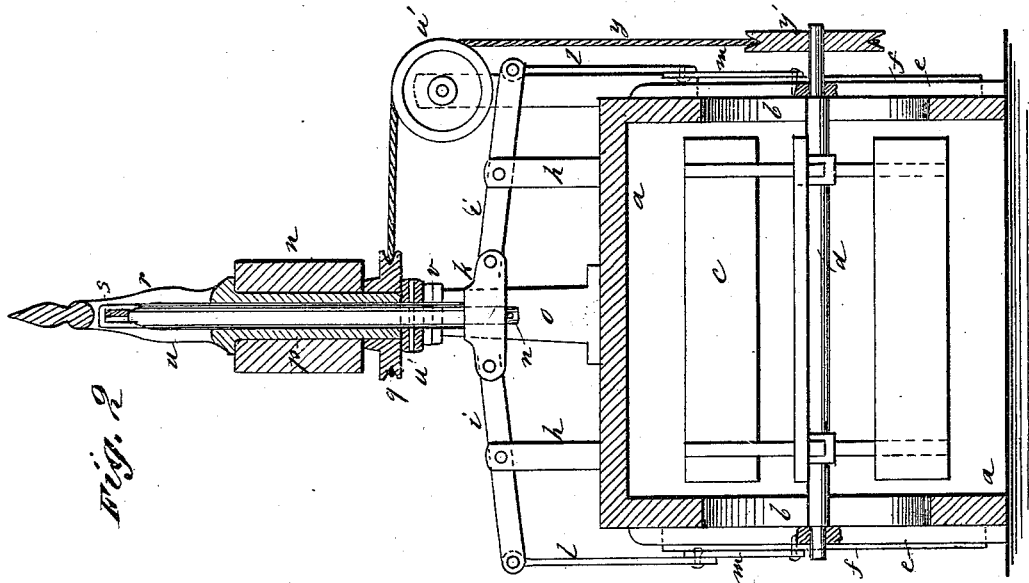

Fig. 2

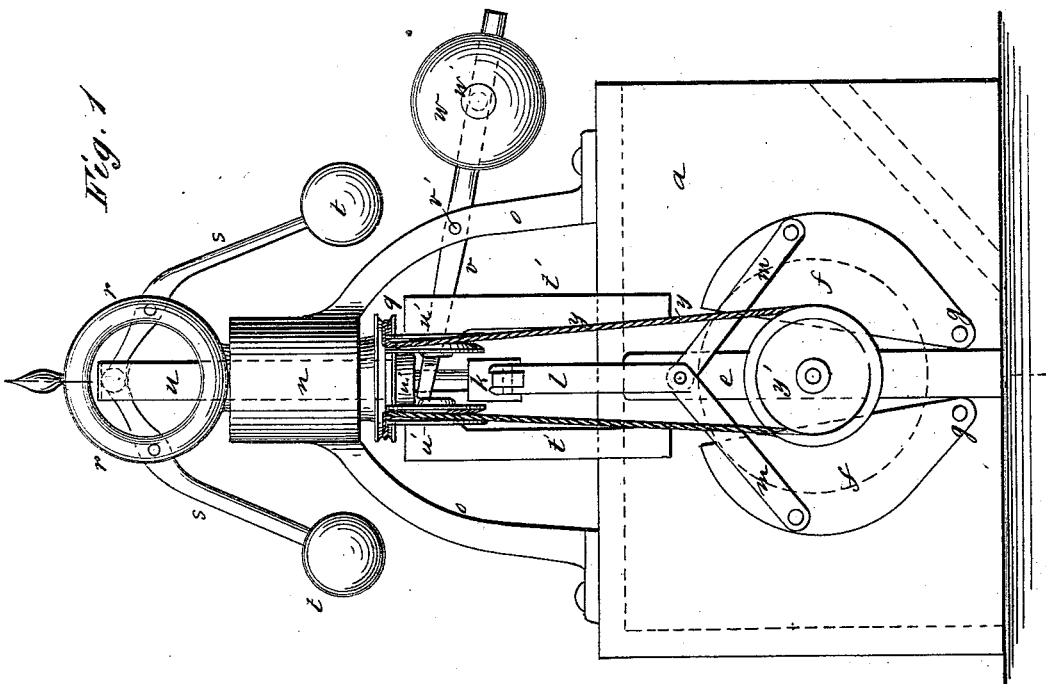

Fig. 1

WITNESSES:

*C. Newell*  
*C. Sedgwick*

INVENTOR:

*J. Hunsinger*  
BY *Henry Ho*

ATTORNEYS.

# UNITED STATES PATENT OFFICE.

JACOB HUNSINGER, OF METAMORA, INDIANA.

IMPROVEMENT IN AIR-BLAST REGULATORS FOR THRASHING-MACHINES, &c.

Specification forming part of Letters Patent No. **212,004**, dated February 4, 1879; application filed October 16, 1878.

*To all whom it may concern:*

Be it known that I, JACOB HUNSINGER, of Metamora, in the county of Franklin and State of Indiana, have invented a new and Improved Air-Blast Regulator for Thrashing-Machines and Fan-Mills, of which the following is a specification:

The object of my invention is to furnish a device for regulating the blast of air from the blower in machines for separating grain from straw or chaff, whereby the riddles may be kept clear of straw at all times, whether the thrasher is running at high or low speed, and the waste of grain which occurs by variations in the blast may be avoided.

In the drawings, Figure 1 is an elevation of one side of a fan-blower case with my regulating apparatus applied thereto, and Fig. 2 is a vertical section of the same.

Similar letters of reference indicate corresponding parts.

*a* represents the case of a fan-blower, connected with a thrashing-machine, or a machine of a similar character, (not shown,) in the usual manner; and *b b* are openings in the side of *a* for the admission of air. *c* is the fan, which is driven by a pulley (not shown) on the fan-shaft *d*; and *e e* are vertical posts across the openings *b b*, forming bearings for the shaft *d*. *f f* are swinging valves or gates, semicircular in form, connected by pivot-pins *g* to the side of the case *a*, adjacent to the openings *b*.

There are two of the valves *f* at each opening *b*, and when closed they rest against the posts *e* and cover the openings *b*.

*h h* are vertical posts upon the top of the case *a*, supporting the horizontal levers *i i*, which are connected at their inner ends over the center of case *a* to a plate, *k*, forming a toggle-joint.

The posts *h* are the fulcrums of levers *i*, and the outer end of each lever *i* projects beyond the side of the case *a*, and is connected to a pitman, *l*. *m m* are links, attached to the valves *f f* and to the pitman *l* at each side of the blower-case. *n* is a cylinder, supported above the blower-case *a* by the standards *o o*, which are bolted to the case *a*. *p* is a hollow vertical shaft, passing through the cylinder

*n*, and having keyed upon its lower end a pulley, *q*, and having its upper end formed as diverging arms *r r*, which arms *r* support the arms *s* of the governor-balls *t*. The inner ends of the arms *s* pass into a mortise in the stem *u*, which passes vertically through the shaft *p*, and has its lower end connected to the plate *k* of the levers *i i*. These parts constitute a centrifugal governor of the usual character.

*v* is a lever, fulcrumed at *v'* on one of the standards *o*. Its inner end is mortised or slotted, to take upon the stem *u* below a collar, *w'*; and the outer end of *v* carries an adjustable weight, *w*, secured in place by a set-screw, *w'*.

The shaft *p* of the governor is driven by a belt, *y*, from a pulley, *y'*, on the shaft *d* of the fan-blower to the pulley *q* of the governor-shaft.

*u' u'* are friction-pulleys, supported on the case *a* upon bearings *t'*, and the belt *y* passes over these pulleys *u'*.

It will be seen that the speed of the governor is regulated by the speed of the thrashing-machine to which the blower is connected, and that the position of the valves *f* is regulated by the rise and fall of the governor-balls *t*.

The increase of speed of the machine will raise the balls *t*, and, by the stem *u*, levers *i*, pitmen *l*, and links *m*, will close the valves *f*, to reduce the force of the blast, while a decrease of speed below the normal point will act to open the valves *f*, and permit a greater quantity of air to pass in to compensate for the loss of speed.

The weighted lever *v* acts to raise the stem *u* and reopen the valves *f* the moment the speed is slackened, thereby assisting the action of the governor.

I do not limit myself to the precise construction set forth.

The form of governor and the connections of the valves therewith may be varied without departing from my invention.

The levers *i* might be connected to the standards *o* and the posts *h* dispensed with.

The inner ends of levers *i* may be jointed together in any desired manner.

Having thus described my invention, I claim as new and desire to secure by Letters Patent—

The combination, with blower *c d* and box *a*, having apertures *b b*, of the valves *f f*; the vertical posts *e*, in which the blower is journaled, the links *m m*, and the pitman *C*, the

latter connected with a governor mechanism, substantially as shown and described.

JACOB HUNSINGER.

Witnesses:

ISAAC WEIR,  
JOHN H. ALLISON.