

E. J. MOLERA & J. C. CEBRIAN.
Motor-Engines.

No. 212,037.

Patented Feb. 4, 1879.

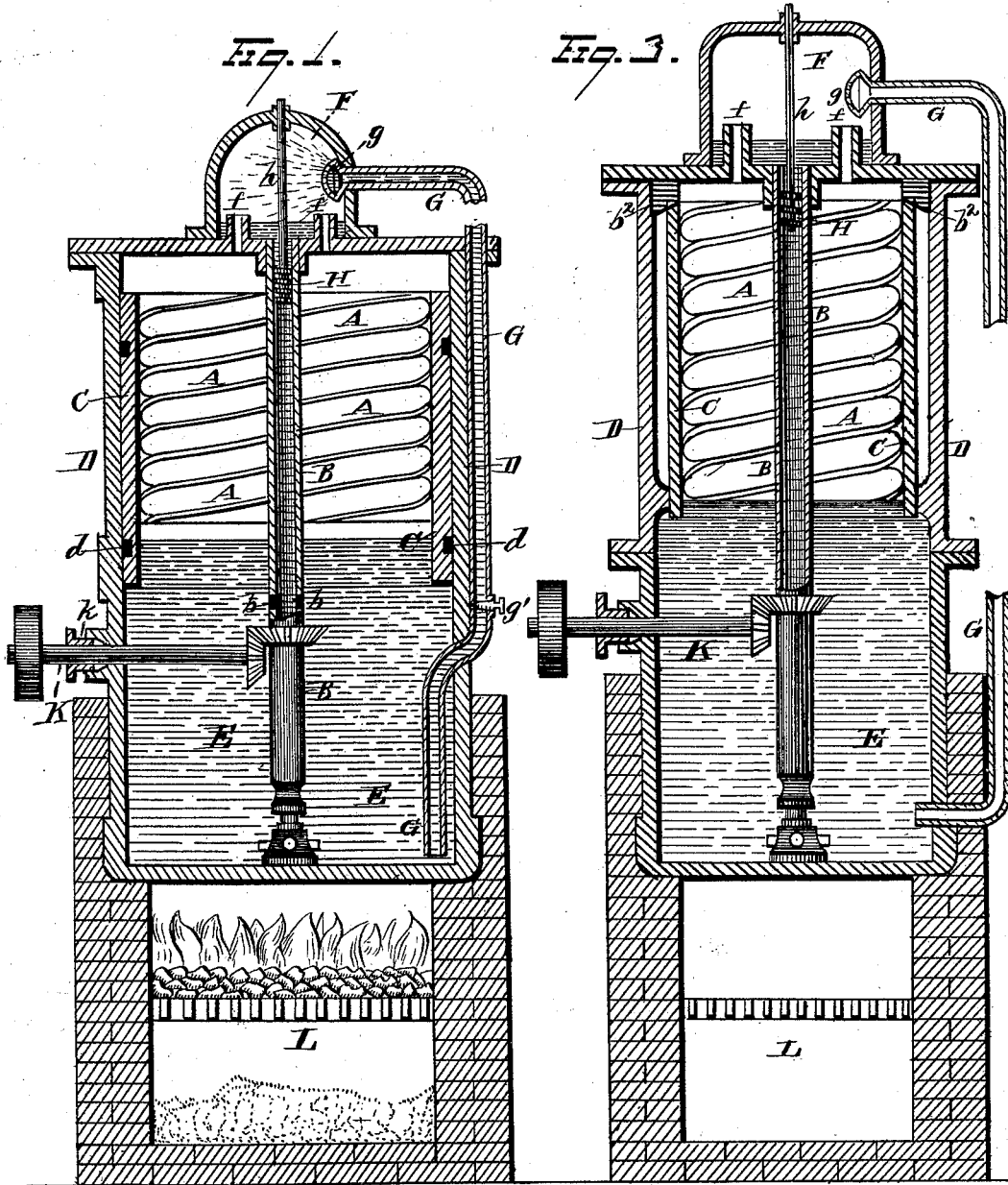

WITNESSES
E. J. Nottingham,
G. Dudley Seymour.

INVENTORS.
E. J. Molera,
J. C. Cebrian,
By *H. A. Seymour,* ATTORNEY

E. J. MOLERA & J. C. CEBRIAN.
Motor-Engines.

No. 212,037.

Patented Feb. 4, 1879.

Fig. 2.

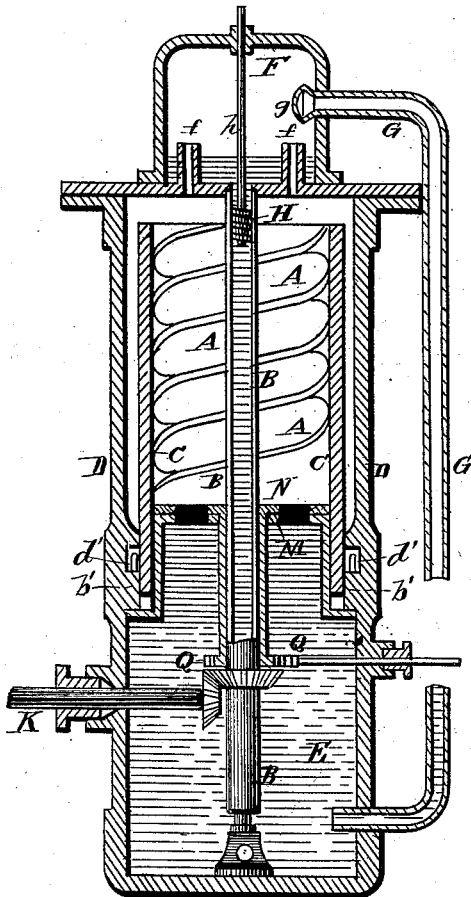
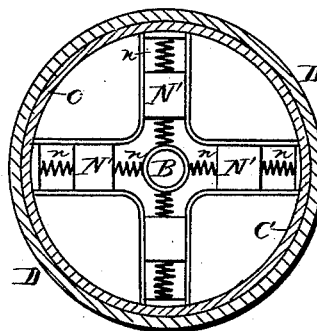
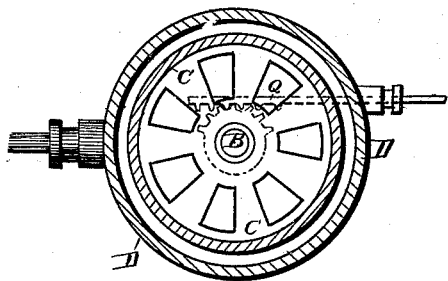
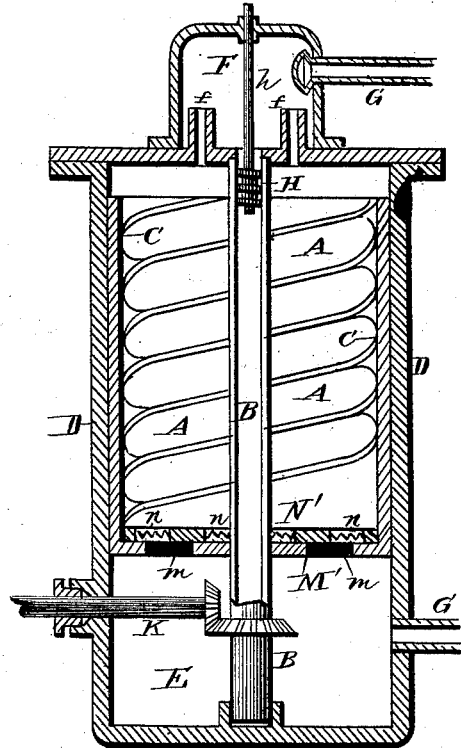

Fig. 4.



WITNESSES
E. J. Nottingham
J. Dudley Seymour

INVENTORS
E. J. Molera.
J. C. Cebrian
By H. A. Seymour, ATTORNEY

UNITED STATES PATENT OFFICE.

EUSEBIOUS J. MOLERA AND JOHN C. CEBRIAN, OF SAN FRANCISCO, CAL.

IMPROVEMENT IN MOTOR-ENGINES.

Specification forming part of Letters Patent No. **212,037**, dated February 4, 1879; application filed November 6, 1878.

To all whom it may concern:

Be it known that we, EUSEBIOUS J. MOLERA and JOHN C. CEBRIAN, of San Francisco, in the county of San Francisco and State of California, have invented certain new and useful Improvements in Motor-Engines; and we do hereby declare the following to be a full, clear, and exact description of the invention, such as will enable others skilled in the art to which it pertains to make and use it, reference being had to the accompanying drawings, which form part of this specification.

The great majority of steam, gas, and vapor motors heretofore used have all several defects, practical as well as technical, which make them very expensive of installation and running expenses, and also of short duration in use.

The boring of perfectly true cylinders is difficult and expensive, and it limits the size of the machines, and also the materials of which to make them.

The construction and maintenance of steam-packed pistons are expensive, difficult, of continual repair, and consequently very liable to get out of order, and cause the waste of the motor used. The stuffing-boxes for piston-rods, valve and cock stems, &c., are also difficult to make, expensive, and inefficient, causing leakages and waste of the motor employed.

The connections of the piston-rod and the rest of the machinery are bulky, complicated, causing many frictions, expensive, and requiring a very perfect construction. Then the motor, after finishing its work, generally has a great tensional power unexpended, which in almost all cases is totally lost.

In many motors the degree of heat required is very high; consequently the heat is very expensive in itself, and is subject, besides, to great losses by radiation, which implies another line of expenses in order to avoid said losses of heat. The leakages of motor, which are always expensive and inconvenient, in some cases render the motor of quite impossible use. For instance, in ammonia-engines the leakages will destroy all brass works. Some of the hydraulic motors, as the water-wheels, for instance, and especially the improved designs lately introduced, avoid many of the above-mentioned defects. Their parts

are easier and cheaper to construct, therefore less liable to get out of order, and of cheaper maintenance; there is not so great a loss of motive power, no loss of heat, and less complication and friction in the transmission of power. The result is that some water-wheels utilize ninety per cent. of the work given by the natural motor used, whereas in the best patterns of steam-engine not much more than thirty-three per cent. of the work given by the fuel consumed is utilized; and in many cases it is only about ten per cent. But the hydraulic motors have two main disadvantages. They require a great amount of water to be used, and also a certain head of water, which limits them to very local uses.

By a series of experiments and researches we have devised a system of motors designed by their improved construction to avoid nearly all or any of the defects and objections above noted, said motors all employing as their actuating medium certain gases or vapors, which, at comparatively low temperatures, acquire great tensional force, in connection with different novel forms of mechanism to be actuated thereby. Some of said forms of mechanism constitute the subject-matter, respectively, of two applications for Letters Patent filed previous to this; and as regards the objections and difficulties above noted as to previously-existing motors, we, of course, do not include therewith the motors set forth in our said two applications for patents.

The preferable construction and operation of the motor forming the subject-matter of this application are as follows: Gas or vapor under pressure is introduced into a chamber in which a screw is located, and which latter is adapted to be actuated in rotation by the pressure of the tension or elastic force of the fluid as the same passes from the induction to the education end of said chamber. This screw is secured to an axial shaft, and inclosed by a lateral drum, the power generated being readily transmitted to any machinery to be operated thereby. By forming the screw of proper length all the available force of the motive fluid may be utilized. If said fluid be steam or other cheap substance, it may be exhausted into the atmosphere. If, however, an expensive substance, such as ammoniacal gas, be

used, then the motive fluid is collected in a condenser and returned to the boiler for repeated use. In instance of both fluids, however, the back-pressure is reduced to a minimum. This construction of motor completely dispenses with steam or gas valves and their connections; hence the numerous objections to such mechanism are obviated. It also causes the action of the motive fluid to be constantly in the same direction, and consequently there are no dead-points or dead moments in the operation of the motor. Pistons and piston-packings are avoided, while at the same time there are no true-bore cylinders to be formed and maintained in operative condition; also, the friction of the different parts is circular and not rectilinear.

In addition to the foregoing there are numerous advantages following as results of such a construction as is set forth.

Our invention consists, first, in a motor-engine, of the combination, with a boiler for the generation of suitable vapors or gases, and provided with one or more eduction-passages, of a horizontally-moving screw secured to the driving-shaft of the motor and located within the upper portion of the boiler; second, in the combination, with a screw actuated in rotation by the expansive force of gas or vapor, and a lateral drum secured thereto, of one or more collars, against which said drum has bearing during rotation; third, in the combination, with a screw actuated in rotation by the pressure of gas or vapor, and a lateral drum secured thereto, of a chamber or casing, in which the latter rotates, together with suitable packing inserted between said drum and chamber; fourth, in the combination, with a chamber or casing having communication with the boiler, and a screw actuated in rotation within the former by the tension of gas or vapor, of a condenser or dissolver, together with connections of the same, respectively, with said chamber and boiler; fifth, in the combination, with a screw actuated in rotation by the tension of gas or vapor within a casing or chamber which communicates with a condenser or dissolver, of a boiler, and a pipe which connects the lower side or bottom of the latter with said condenser or dissolver; sixth, in the combination, with a screw actuated in rotation within a chamber or casing by the tension of gas vapor, and a boiler, of a condenser or dissolver connecting with the eduction end of said chamber, and having communication also with the upper body of the boiler; seventh, in the combination, with a screw actuated in rotation within a chamber or casing by the tension of gas or vapor, a boiler, and a condenser or dissolver, of pipe-communications of the latter, respectively, with the upper and lower body of the boiler and the eduction end of said screw-chamber; eighth, in the combination, with a screw actuated in rotation by the tension of gas or vapor, and secured to a tubular axial shaft, of a condenser or dissolver having communication with the upper body of the

boiler through said shaft; ninth, in the combination, with a chamber or casing provided with a screw which is actuated in rotation by gas or vapor, of a condenser or dissolver connecting with the eduction end of said chamber, and mechanism adapted to force the motive fluid therefrom into the boiler; tenth, in a motor-engine provided with a screw which is rotated by gas or vapor in a state of tension, the combination, with a condenser or dissolver, and pipe-connection of the same with a boiler, of an inverted screw located longitudinally within said pipe and free therefrom, the same being adapted to force the motive fluid into said boiler; eleventh, in the combination, with a screw actuated in rotation by the tension of gas or vapor, and secured to a tubular axial shaft, which latter provides communication between the boiler and condenser or dissolver, of a screw located within said shaft, and adapted to force the fluid from said condenser or dissolver into the boiler; twelfth, in the combination, with a screw actuated in rotation by the tension of gas or vapor, and a tubular axial shaft, to which it is secured, and which provides communication between the boiler and the condenser or dissolver, of a fixed screw located longitudinally within said shaft and free therefrom, said screw having its thread formed the reverse of the thread of the rotating screw; thirteenth, in the combination, with a screw or screw-connecting mechanism rotated within a casing or chamber by the tension of gas or vapor, of mechanism engaging therewith, and adapted to transmit the generated power to any desired machine or machinery.

Referring to the drawings, Figure 1 is a view, in vertical central section, of one form of motor embodying our invention. Fig. 2 represents, in vertical central section, and also in transverse section, a form of motor provided with governor mechanism. Fig. 3 is a view, in vertical central section, of a modification of the invention. Fig. 4 represents, in vertical central section, and also in transverse section, a form of motor provided with governor mechanism different from that shown in Fig. 2.

The screw A is, in these instances, secured to a vertical tubular shaft, B, having openings *b*, one or more, connected with the upper body of the boiler. C is the cylindrical wall or drum, laterally inclosing the screw, and adapted to confine the motive fluid to a passage up through the latter. In this particular instance the chamber or casing D, within which the screw and inclosing-drum rotate, is extended downward, and thereby constitutes the boiler E. Two ring-packings, *d*, are interposed between said drum and chamber. F is the condenser or dissolver, communicating with chamber D by one or more conduits, *f*. The tubular shaft constitutes the feeding-pipe from said condenser to the boiler, while pipe G connects the lower side or bottom of the latter with the condenser.

If desired, a rose, *g*, may be formed at the

discharge end of said pipe. A cock or valve, *g'*, regulates the flow of the liquid through the pipe.

The upper extremity of the tubular shaft is provided with a screw, *H*, depending from a stationary stem, *h*, and having its thread formed the reverse of the thread of screw *A*. *K* is a shaft, driven by shaft *B*, and may be connected with any manner of machinery. A fire-place, *L*, is also shown in the views.

In order to make our invention clearly understood, we will suppose the boiler to contain a rich solution of ammoniacal gas in water, the same being given simply as an illustration, and not limiting our invention, inasmuch as any other kind or mixture of solutions, any kind of mixture of liquids and their vapors, and any gas or gases kept in a liquid or gaseous state, may be substituted for ammonia, as desired.

The operation of the motor is as follows: Under the influence of heat the gas will disengage from its solution and impinge against the screw, thus actuating the latter in rotation, as well as the axial shaft and the laterally-inclosing drum of the same. By the time that the gas reaches the eduction end of the chamber it will have expended the greatest part of its energy upon the rotating screw, and will be cooler. Sufficient tension, however, will be left to carry it through the eduction-conduits into the condenser or dissolver. At the same time the liquid near the bottom of the boiler will be nearly free of ammonia, and the pressure within said boiler will force said liquid up through pipe *G* into the condenser or dissolver, where it will again meet the gas which passes through conduits *f*, and dissolve the same, thus obtaining in the dissolver a solution equal to that contained in the boiler, only cooler than the same. The rotation of the tubular shaft about the fixed inverted screw *H*, suspended within the same, will force the solution in the condenser or dissolver down through said tubular shaft and out into the upper body of the boiler, thus closing the circuit of the motive fluid.

By properly adjusting the valve located within pipe *G*, we may regulate the flow of liquid into the condenser or dissolver so that the same may be just sufficient to absorb the exhaust-gas. The tension of the fluid within the boiler will be transmitted through openings *b* into the tubular shaft and against the flow of liquid passing down through the same. It therefore operates in tendency to prevent the rotation of said tubular shaft; but inasmuch as the same tension is simultaneously acting on the full area of the screw-inclosing drum, it causes the rotation of said screw and axial shaft with a much greater degree of power. Hence the downward force of the liquid within the tubular shaft will always overcome the upward force.

By maintaining the temperature of the fire-place or of the boiler constant, we will obtain a constant flow of gas and of liquid, as de-

scribed, which, as a result, produces a constant action of the motor.

The construction of our motor is in no sense of the word limited to the forms represented in the several views. The boiler and the fire-place may be of any shape whatever. The former we have shown as constituting part of the chamber or casing within which the rotating screw works, in order to give our motor a compact form; but, instead thereof, the boiler may be formed independent from said chamber, or may be removed entirely from the same, in which case an opening should lead from the boiler to the lower area of the screw-drum, in order to allow the motive fluid to enter through the lower opening of the rotating screw. The fire-place and the boiler might also be formed so as to avoid heating the pivotal bearing of the axial shaft of the rotating screw, even while maintaining said pivotal bearing within the boiler.

In the majority of instances it would not be a disadvantage to have the pivotal bearing within the boiler, since the temperature of the latter would not be high—that for ammoniacal gas, as an instance, being sufficient at 100° Fahrenheit.

In instance of the pivotal bearing being outside of the boiler, we may employ a stuffing-box at some point of the axial shaft, and therefore dispense with stuffing-box *k*, (represented in the drawings,) inasmuch as shaft *K* would in such case also be outside of the boiler. The boiler may be provided with glass and cock gages, safety-valve, feeding-opening, and all other desired attachments. The governor in this case should differ somewhat from the usual steam-governors. One style of governor, as shown in Fig. 2, may consist of a stationary diaphragm or disk, *M*, suitably perforated, and placed between the boiler and the lower end of the rotating screw. A second disk, *N*, is located close to the first, and adapted to have a reciprocal movement, whether angular or rectilinear, so that it will open the perforations or openings of the stationary disk to a certain extent, more or less, when moved. In said Fig. 2 the plate *N* is shown to have an angular motion imparted to it by means of the rack 2, operating on a portion of a pinion made fast to *N*; but said motion may be given by any system of levers, springs, or otherwise, and it may be angular or rectilinear. It is only necessary to connect said movable disk or plate (through the rack 2, or otherwise) with an ordinary governor mechanism.

Another class of governors is shown in Fig. 4. *M'* is a disk, fastened to the shaft or to the drum, and revolving with it. It has one or more openings, *m*, to allow the motive fluid to pass to the screw-space. On top or below said disk there are several plates, *N'*, covering one or more openings, *m*. Said plates may be guided by proper guides or not. They are attached to two springs, *n*, one of which is made solid to the shaft or to the plate *M'* near the shaft, and the other spring to the drum or to

plate M' near the drum; or else only one of the two springs may also be used. Said springs may be of any material, shape, or size whatever, as long as they allow the plates N' to have a radial reciprocating motion. Said springs are balanced in such a way that when the screw is at rest the plate or plates N' leave the opening or openings m' full open or nearly full open. When the screw is set in rotary motion the centrifugal force will send the plates N' away from the shaft, and they will partially shut the openings m' , thus regulating the flow of the motive fluid without the intervention of any other governor mechanism. By a proper adjustment of the springs of N' we may have the openings m' altogether closed as soon as the shaft and screw attain a certain speed, and therefore the speed of the motor-engine is perfectly controllable. Should the connection between the boiler and the rotating screw be a pipe, then any of the ordinary steam-governors can be used.

Another kind of governors for these motors, and one which in many cases is preferable, should be of such character as will admit of the fire or other source of heat being controlled thereby. A fire-damper placed either at the smoke-stack or at the grate-door, or even a suitable screen located within the fire-place, may be used. These dampers or screens should be connected with ordinary governor mechanism, which latter may be actuated in the well-known manner. If the fire used should be gas or liquid under the control of keys or wicks, said governor mechanism may act directly upon the latter to produce the desired effect.

The rotating screw may be of any construction and of any appropriate material. One, two, or more blades may be formed thereon. A single thread, or several threads, may be formed, all of which, together with the pitch and total length of the screw, may vary according to the requirements of the machine.

The screw-drum, as well as the casing or chamber in which the same works, may be made of any suitable material. If desired, said casing or chamber may be formed with one or more inwardly-projecting collars, which provide lateral bearing for the drum. This collar or collars may be formed by hollowing out the interior side of the casing or chamber, or even by cutting the same in the middle.

We have represented this casing or chamber as made of one piece, in order to prevent more effectually the escape of any motive fluid between the same and the screw-drum. For the same reason, although it is not absolutely necessary, said drum may be made sufficiently long to extend down into the liquid within the boiler, which will greatly decrease such escape. If such escape should obtain, there would be a loss of motive power rather than of motive fluid; but to guard against the same, we prefer to have packing interposed between said drum and casing or chamber.

In Fig. 1 we have represented two rings, d , of any suitable material, as steel, rubber, hemp,

liquid, or other substance. There may be several of the same; or the latter may be substituted by one or more spirals, which will be more effective by having the direction of their thread the reverse of the thread of the rotating screw.

In Fig. 2 a different form of packing is shown, the same being one or more hydraulic-pressure packings, d' . This figure also represents the chamber or casing as formed with a single collar, b^1 , against which the screw-drum has bearing, thus reducing considerably the friction caused by the rotation of the latter against the side of said casing or chamber.

In Fig. 3 a collar, b^2 , having an inclined or coniform bearing-face, is represented. The contact between the drum and the chamber or casing will constantly be tight, by reason of the tension of the motive fluid against the rotating screw, which forces the latter, together with the drum, upward. The bearing-surface of this collar b^2 may be spherical, cylindrical, or otherwise, and any suitable packing may be used therewith. In brief, we may use between the screw-drum and its casing or chamber, whether the latter be with or without collars, any effectual packing not herein mentioned without departing from our invention.

If desired, the screw-drum itself may be dispensed with, the blades of the screw being in such instance made sufficiently thick to prevent escape of the motive fluid between their edges and the wall of the chamber or casing; or suitable rims may be formed on the edges of said blades; or grooves may be made in said edges or rims, and packed; or any other form of packing may be substituted. However, though the drum is not absolutely necessary for our motor, yet we consider that its employment simplifies the construction of the latter.

The chamber or casing, even in a form of motor essentially such as is shown in Fig. 1, may be in a separate piece from the boiler, and separated therefrom by a suitable joint. In such instance, we may insert in said joint some non-conducting material, so as to avoid a high temperature in the frictional surfaces of the drum, and chamber or casing, and in the top surface of the rotating screw.

The dissolver or condenser may also be of any suitable form and material. It may be located directly on the top of the chamber or casing, as shown in the drawings, or otherwise, provided only that the same communicates with the top of the screw-space or chamber in which the rotating screw works. Such communication may be had through any kind of pipes, openings, or equivalent connections. In the instance of the condenser or dissolver being located directly on the top of the chamber or casing, as shown in the drawings, we may use some non-conducting material in the joint-packing of the cover of said chamber, or between the chamber and the condenser or dis-

solver, the same being adapted to prevent the heat of the motor from warming said condenser or dissolver, and thus favor the solution or condensation of the motive fluid. Likewise, said condenser or dissolver, or its communication with the rotating screw-chamber, may be connected in any desired manner with a refrigerator, or even be inclosed within the latter, so as to hasten the solution or condensation.

The screw-shaft may be solid or hollow, and in the latter case may be employed as a feeding-pipe for the boiler or not. If not so employed, a separate pipe or other appropriate communication may serve as a feeding medium; and at any point of said connection, a force-pump or other suitable device may be introduced, in order to provide effectual feeding. Such feeding-pipe may come from the condenser or dissolver, if the latter be used, or from elsewhere. This screw-shaft may be supported by a pivot, *c*, and a collar, *c'*, both of which latter may be in the form of any of the well-known devices for similar purposes. Adjusting-screws, oil-cups, feeders, and seats may also be employed, the same not being shown in the drawings or further described, as they may be of any desired character.

The screw-shaft or the collar *c'* may be provided with suitable shoulders, to prevent the rotating screw from yielding to the upward tendency imparted by the motive fluid. Said collar may be located at the extremity of the screw-shaft, or at any other point thereof; so, too, the shaft itself may extend upward to or beyond the top of the condenser or dissolver. All those parts of the motor most subject to wear and tear, such as the above-said shoulders and their abutments, the collar *C'* of Fig. 3, and the upper end of drum and other similar ones, may be made in separate pieces, screwed or otherwise fastened in their proper places, so as to be renewed, when necessary, at a trifling cost and with little loss of time.

The screw-shaft, and consequently the rotating screw itself, its casing, guides, and other connections may have any inclination whatever, although in most instances a vertical position is preferable, and a horizontal position will probably be the least advantageous in practice. In instances of horizontal position, the pivot and collar above described may be substituted by suitable bearings.

As hereinbefore indicated, the screw-shaft may extend beyond the boiler, or beyond the condenser or dissolver, through stuffing-boxes. It may also be inclosed in any cover or pipe, as is employed in some water-turbines.

The connection of the screw-shaft with the shaft which transmits the generated power to the machinery to be operated thereby may be of any desired character.

Instead of the screw-shaft being the part of the motor which engages with the power-transmitting shaft, this latter shaft may connect in other manner. Thus, we may attach gearing, straight, beveled, or of other form, directly to

the lower or the upper, or to both the lower and upper, body of the rotating screw, said gearing to be independent of or connected with the screw-shaft. We may also form or connect said gearing or gearings with the exterior surface of the drum, when a portion of the latter is exposed outside of the chamber or casing. Such gearing in any instance may be substituted by belts, pulleys, and similar mechanical devices.

In the drawings we form the stationary screw *H* rigid with the stem, from which it is depended in an inverted position within the tubular screw-shaft, the same being adapted to force the solution contained within the condenser or dissolver down through said shaft and into the boiler, the shape and size of this secondary screw depending upon the duty required of the motor; but, as stated in the preceding description, we may employ any other pipe, the latter being movable and the interior screw stationary, or the reverse, or both the same being movable; or we may dispense with said screw *H* entirely, and use other mechanism for feeding the boiler.

The communication between the condenser or dissolver and the lower side or bottom of the boiler may be of any suitable character. The position of the valve governing the flow of liquid therethrough may vary. Any governor mechanism driven by the motor or the machinery operated by the latter may be connected with said communication. Said communication may pass through or be anywise connected with a proper refrigerator, if so desired.

The rotating screw-shaft may be utilized to serve the same purpose of pipe *G*, whether employed as a boiler-feeding pipe or not.

The feeding communication from the dissolver or condenser to the boiler may be provided with regulating valves or cocks, which may also be controlled by governor mechanism.

Instead of a liquid solution in the boiler, we may employ one or more liquids to be evaporated, or one or more gases kept in a liquid or gaseous condition, in which cases we may dispense with the connection *G*.

We may also use an additional receiver to collect the liquefied substance in the condenser or dissolver after the same has undergone the process of liquefaction or condensation in the condenser or refrigerator, as the case may be. The communication between said receiver and the boiler may also be provided with a controlling cock or valve.

It will be understood that we may use in any part of our motor any isolating covering, if considered desirable.

The foregoing description has been based upon the illustration of our principle of invention as applied to a form of motor in which the motive fluid first impinges against the lower body of the rotating screw. By properly forming the relative positions of the different parts of the motor, however, the mo-

tive fluid may first impinge against the top of the rotating screw, and exhaust from its lower extremity, such construction being included within our invention.

It will be observed that a motor constructed according to our invention readily combines compactness of shape, simplicity and cheapness of construction, simplicity of management, together with low cost of running expenses, the avoidance of fluid escape, and the widest range of practical size. An engine is thus produced well adapted for stationary and for movable purposes, and one which may as well be used for the largest power required in operations of industry as for the no less important purpose of supplying a very small, practical, and economical motor for house and domestic use.

Having fully described our invention, what we claim as new, and desire to secure by Letters Patent, is—

1. The combination, with a boiler having a vapor-education port, one or more, at the upper end thereof, of a horizontally-moving screw attached to the driving-shaft of the motor, and located within the upper portion of said boiler, substantially as set forth.

2. In a motor-engine, the combination, with a screw actuated in rotation by the pressure of gas or vapor, and a lateral drum secured thereto, of a chamber or casing, in which the latter rotates, together with suitable packing inserted between said drum and chamber, substantially as set forth.

3. In a motor-engine, the combination, with a chamber or casing having communication with the boiler, and a screw actuated in rotation within the former by the tension of the gas or vapor, of a condenser or dissolver, together with connections of the same, respectively, with said chamber and boiler, substantially as set forth.

4. In a motor-engine, the combination, with a screw actuated in rotation within a chamber or casing by the tension of gas or vapor, and a boiler, of a condenser or dissolver connecting with the education end of said chamber, and having communication also with the upper body of the boiler, substantially as set forth.

5. In a motor-engine, the combination, with a screw actuated in rotation within a chamber or casing by the tension of gas or vapor, a boiler, and a condenser or dissolver, of pipe-communications of the latter, respectively, with the upper and lower body of the boiler and the education end of said screw-chamber, substantially as set forth.

6. In a motor-engine, the combination, with a screw actuated in rotation by the tension of gas or vapor, and secured to a tubular axial shaft, of a condenser or dissolver having communication with the upper body of the boiler through said shaft, substantially as set forth.

7. In a motor-engine, the combination, with a chamber or casing provided with a screw,

which is actuated in rotation by gas or vapor, of a condenser or dissolver connecting with the education end of said chamber, and mechanism adapted to force the motive fluid therefrom into the boiler, substantially as set forth.

8. In a motor-engine provided with a screw which is rotated by gas or vapor in a state of tension, the combination, with a condenser or dissolver and pipe-connection of the same with a boiler, of an inverted screw located longitudinally within said pipe and free therefrom, the same being adapted, to force the motive fluid into said boiler, substantially as set forth.

9. In a motor-engine, the combination, with a screw actuated in rotation by the tension of gas or vapor and secured to a tubular axial shaft, which latter provides communication between the boiler and condenser or dissolver, of a screw located within said shaft and adapted to force the fluid from said condenser or dissolver into the boiler, substantially as set forth.

10. In a motor-engine, the combination, with a screw actuated in rotation by the tension of gas or vapor, and a tubular axial shaft, to which it is secured, and which provides communication between the boiler and the condenser or dissolver, of a fixed screw located longitudinally within said shaft and free therefrom, said screw having its thread formed the reverse of the thread of the rotating screw, substantially as set forth.

11. In a motor-engine actuated by the expansive force of certain gases or vapors against a screw, the combination, with the screw-chamber or space, of a perforated plate or diaphragm inclosing its fluid, induction end, and adjustable valve mechanism controlling said perforations or openings, the same being adapted to automatically govern the supply of motive fluid into said screw chamber or space, substantially as set forth.

12. In a motor-engine actuated by the expansive force of certain gases or vapors against a rotating screw, a governor, consisting in the combination, with the screw chamber or space, of adjustable devices adapted to control the passage of the motive fluid therein, together with governor-connecting mechanism, substantially as set forth.

13. In a motor-engine actuated by the expansion force of certain gases or vapors against a rotating screw, the combination, with the screw-chamber having communication at its education end with a condenser or dissolver, of a governor located at the opposite and induction end of said chamber, whereby the passage of motive fluid into the latter is controlled, substantially as set forth.

In testimony that we claim the foregoing we have hereunto set our hands this 21st day of October, 1878.

EUSEBIOS J. MOLERA.
JOHN C. CEBRIAN.

Witnesses:

F. O. WEGENER,
ANDRES MAURI.