

A. STONER.
Fire-Extinguisher.

No. 212,067.

Patented Feb. 4, 1879.

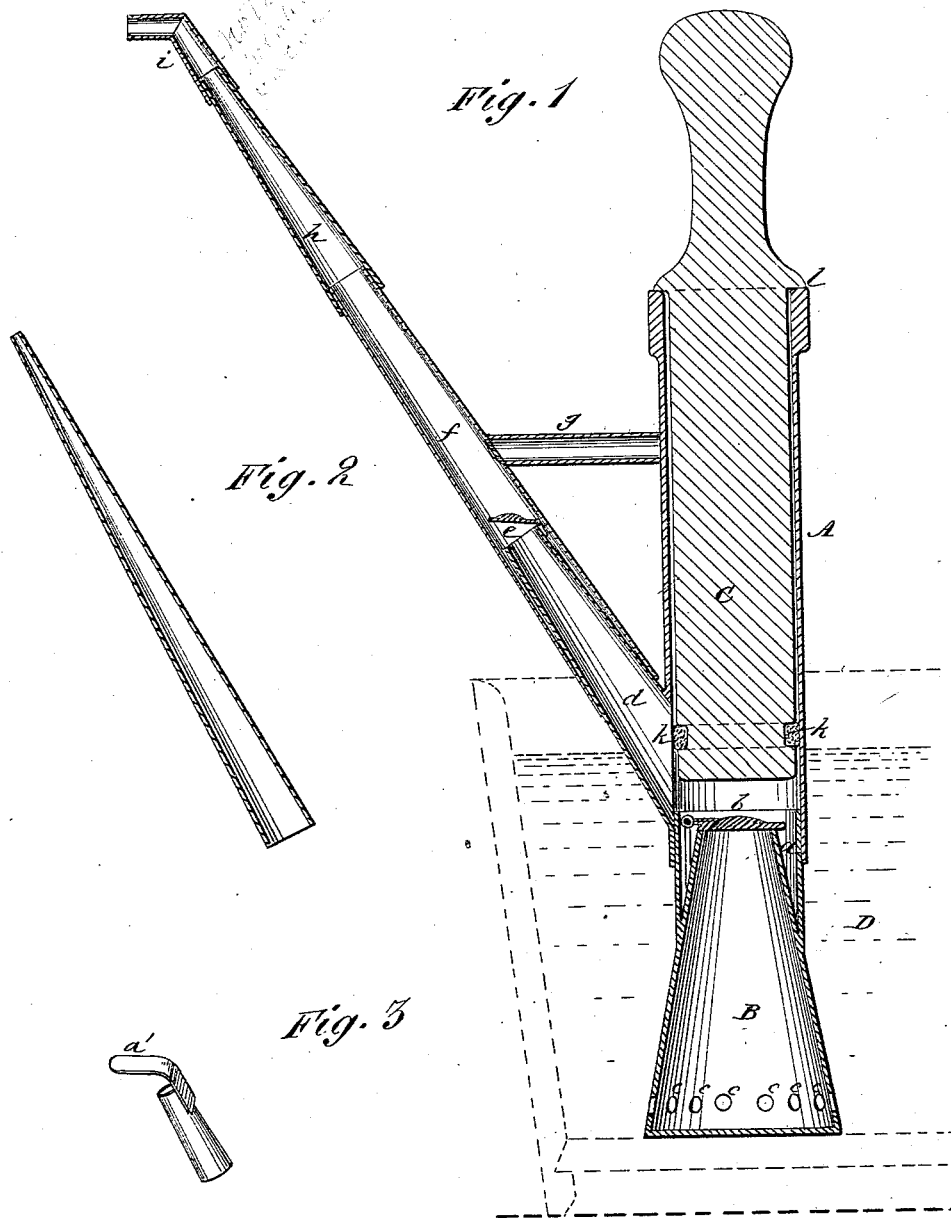

WITNESSES:
C. Neveu
C. Souquien

INVENTOR:
A. Stoner
BY *Munn & Co.*
ATTORNEYS.

UNITED STATES PATENT OFFICE.

ABRAHAM STONER; OF STONY POINT P. O., LOUISIANA.

IMPROVEMENT IN FIRE-EXTINGUISHERS.

Specification forming part of Letters Patent No. **212,067**, dated February 4, 1879; application filed November 9, 1878.

To all whom it may concern:

Be it known that I, ABRAHAM STONER, of Stony Point P. O., in the parish of East Baton Rouge and State of Louisiana, have invented a new and improved Fire-Extinguisher, of which the following is a specification:

The object of this invention is to furnish a simple, light, and easily-operated device for extinguishing fires, washing windows, sprinkling floors, &c.

The invention will first be described in connection with the drawings and all that is necessary to a full understanding thereof, and then be pointed out in the claim.

In the accompanying drawings, Figure 1 is a vertical longitudinal section of my improvement, and Figs. 2 and 3 represent different forms of nozzles used with the device.

Similar letters of reference indicate corresponding parts.

Referring to the drawings, A represents a cylinder, made of tin or other light sheet metal. The lower end of this cylinder is joined to a short tube, *a*, forming a neck, which connects it with the frustum of a conical tube, B, the end of which is covered by a valve, *b*, hinged on one side to the neck *a*. The bottom of the cone is covered, but in the sides is a row of perforations, designated by the letters *c c*, &c.

From the cylinder, just above the valve *b*, projects at an acute angle the conical tube *d*, one end opening into the cylinder, while the other is provided with a valve, *e*. Joined to this cone is another tube, *f*, which is connected with the cylinder A by a horizontal brace, *g*, soldered at its ends to the adjacent parts. On tube *f* is placed another tube, *h*, and to this is joined the nozzle *i*, elbow-shaped, so that its vent is at right angles to the cylinder A.

The tubes *d f h* and nozzle *i* are frustums of cones, so that there is a gradual decrease of diameter from the cylinder to the vent, and thus the body of water first entering the tube from the cylinder is compressed toward its end or nozzle, and thus, when subjected to pressure, is expelled with more or less force, according to the pressure exerted upon it.

In cylinder A is a piston, C, packed near its extremity with any suitable packing material, *k*. This piston extends out of the cylinder A, and is provided with a circular shoulder, *l*, that, striking against the top of the cylinder, limits the downward movement of the piston, and thus prevents it from coming in contact with the valve *b*. The upper end of this piston is turned to form a handle, for convenience in operating it.

The operation of this invention is as follows: The apparatus is placed in a bucket, D, filled with water, with the bottom of the cone resting on the bottom of the bucket, as clearly shown in the drawings. Now, by drawing up the piston a vacuum is made below it, and the water, under the pressure of the atmosphere, rushes through the apertures *c c*, filling the cone and the cylinder A below the end of the piston as high as the pressure of the atmosphere will force it. The piston is then forced down, the pressure of the water closes the valve *b*, and, there being no other exit for the water, it is forced up the conical tube *d* through the valve *e*, and then it is expelled from the nozzle with a violence proportionate to the amount of pressure exerted upon it by the piston. When the piston is driven down as far as it will go, if the conflagration is not yet extinguished, or (if the device is being used for washing windows, if they are not sufficiently washed) the piston is again drawn up, creating a vacuum as before, the pressure of the atmosphere closes the valve *e*, and the water, rushing in, fills the cone, forces open valve *b*, fills the cylinder, and, on the downward movement of the piston, is ejected as before. This is continued until the water in the bucket is exhausted, or there is nothing left to play the water on, when the apparatus is carried off and the bucket refilled if its further use is desirable; if not, it is stored away.

The nozzle fixed to the machine shown in the drawings, it will be observed, is of an elbow-like form, so that the water is projected at right angles to the cylinder; but I do not confine myself to the use of this nozzle exclusively. A straight nozzle, Fig. 2, may be applied instead of the one shown if it is desired to project the stream upward instead of straight out from the operator, as when the fire is in the roof or upper part of the house.

When used as a sprinkler, the nozzle shown in Fig. 3 is used. This is a straight nozzle like Fig. 2; but over it is bent a shield, *a'*, soldered

at one end to the nozzle. The water ejected from the nozzle strikes this shield, and the impact sprays it so that it is delivered in fine drops.

This device can be used for a variety of purposes, and is a valuable novelty. It is useful as a fire-extinguisher, as a window-washer, or as a sprinkler for floors, walks, &c.

I am aware that it is not new to draw up a liquid by means of a vacuum into one chamber, and then force it with a piston to pass

through an outlet-pipe, valves being employed substantially as in my invention; but

What I claim is—

A force-pump consisting of the cylinder A, short tube *a*, end-valved conical tube *d*, and top-valved conical frustum B, having water-inlets *c*, as shown and described.

ABRAHAM STONER.

Witnesses:

ALLEN CASTLE WATSON,
E. J. STILLMAN.