

S. L. STORY.  
Fluting-Iron.

No. 212,159.

Patented Feb. 11, 1879.

Fig. 1.

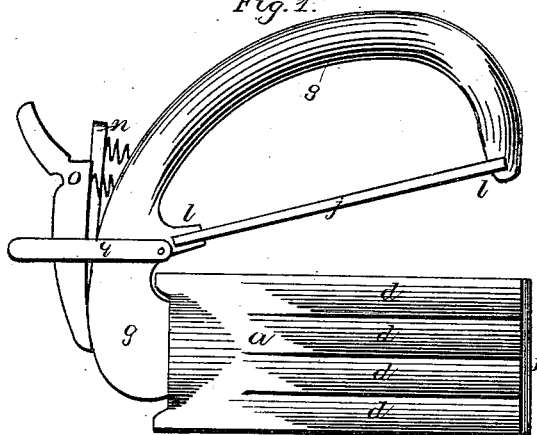

Fig. 2.

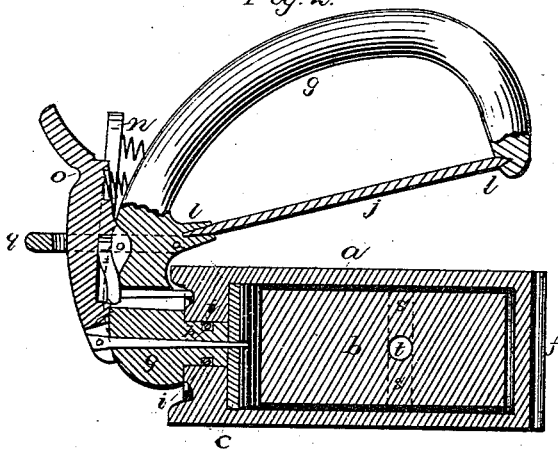

Fig. 3.

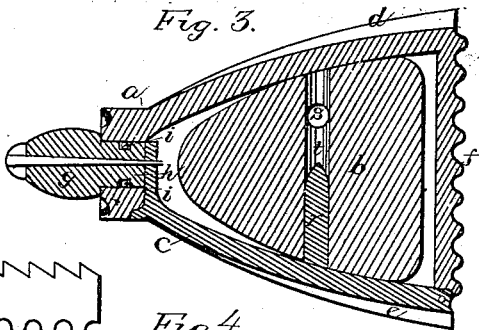

Fig. 5.

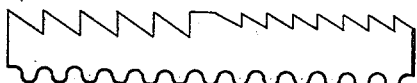
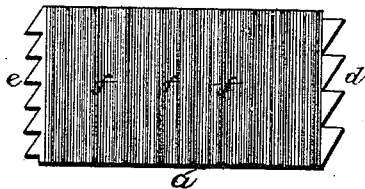

Fig. 4.



Witnesses:

*J. W. Garner*  
*W. S. O. Garner*

Inventor:

*S. L. Story,*  
per  
*J. A. Lehmann,*  
att'y

# UNITED STATES PATENT OFFICE.

SAMUEL L. STORY, OF HILLSBOROUGH, KENTUCKY.

## IMPROVEMENT IN FLUTING-IRONS.

Specification forming part of Letters Patent No. 212,159, dated February 11, 1879; application filed November 27, 1878.

*To all whom it may concern:*

Be it known that I, SAMUEL L. STORY, of Hillsborough, in the county of Fleming and State of Kentucky, have invented certain new and useful Improvements in Fluting-Irons; and I do hereby declare the following to be a full, clear, and exact description of the invention, such as will enable others skilled in the art to which it pertains to make and use it, reference being had to the accompanying drawings, which form part of this specification.

My invention relates to an improvement in fluting-irons; and it consists in the combination of an operating-lever, pivoted on the front end of the handle, for operating the rod which holds the weight in position and the door shut, with a pivoted loop, which holds the lower end of the lever pressed outward, so as to allow the weight and door to be freely moved.

It further consists in the peculiar construction and arrangement of parts, that will be more fully described hereinafter.

Figure 1 is a side elevation of my invention. Fig. 2 is a longitudinal vertical section of the same, and Fig. 3 is a longitudinal section. Fig. 4 is a rear-end view. Fig. 5 is an edge view of the ironing-board.

*a* represents the body of the iron, which is made hollow to receive the core *b*, and which is provided with the hinged door *c*. Upon one edge of the body are made the large inclined recesses *d*, on the opposite side the small inclined recesses *e*, and on the rear end the corrugations *f*, while its top and body are made flat and smooth for ironing. This body is connected to the ironing-handle *g* at its front end only, so that the rear end of the handle will not be in the way when the corrugations *f* are being used. The lower front end of this handle forms the projection *h*, which enters the front end of the body *a*, as shown, and which is grooved all around, so as to receive the two pins *i*, which serve to swivel the body upon the handle. By thus connecting the body and handle together the body can revolve freely around upon the projection without the slightest danger of coming off, and without a pivot at the rear end of the handle.

Between the handle and the body of the

iron is placed the guard *j*, which prevents the heat from rising up around the hand. Upon the handle are formed the two projections *l*, both of which are grooved, so as to receive the cut-away portions of the guard. By forcing the small end of the guard forward into its groove the rear end of the guard can be raised upward past its projection, and then, by moving the guard backward, it will be held supported between the two with sufficient security to require some little force to displace it.

Pivoted upon the front end of the handle are the two spring-levers *n o*, the one, *n*, having connected to its lower end the locking-rod, which holds the body in any one of the four positions while being used, while the outer lever, *o*, has the rod connected to its lower end for locking both the core in position and the door shut. These two levers are pivoted one upon the other, and have their upper ends so close together that either one can be operated by the thumb.

In order to hold the upper end of the outer lever, *o*, pressed back, and thus draw its locking-rod so far outward that it will not interfere with the replacement of the core or the closing of the door, the loop *q* is used. This loop is pivoted upon the handle, and catches in the notch in the upper end of the lever, and thus holds the upper end pressed back until it is desired to again lock the core and door in position.

Upon the inner side of the door, a little back of its center, is raised the projection *r*, which catches in the hole in the core, and thus holds the core in position, not only while the iron is being used, but while the door is being closed.

In the core is made a second hole, *s*, which runs at right angles to the one *t*, and which serves for the poker or lifter to catch in in carrying the core from the fire to the iron.

The iron is first set on its end after the core has become cold, the lever *o* pressed back, and the loop moved up to hold it in that position. The door is then pulled down, which brings the core with it, when it can be removed upon the end of the poker or lifter and replaced by another one.

The board to be used with this iron for plait-

ing and fluting will have the corrugations on one side and the two sizes of inclined recesses on the other.

Having thus described my invention, I claim—

The combination of the handle, the body swiveled thereon, and the two operating-levers, pivoted together on the same pivot on the front end of the lever, substantially as shown.

In testimony that I claim the foregoing I have hereunto set my hand this 18th day of November, 1878.

SAMUEL LEWIS STORY.

Witnesses:

WILLIAM MASON COLLINS,  
DAVID WILLSON.