

G. DAVIS.
 Straw-Band Attachment for Grain-Binders.
 No. 212,200. Patented Feb. 11, 1879.

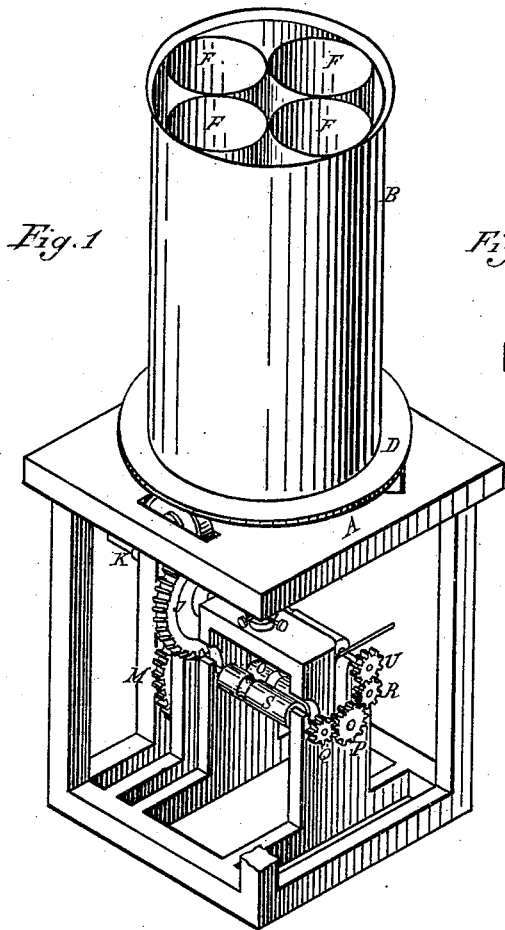

Fig. 1

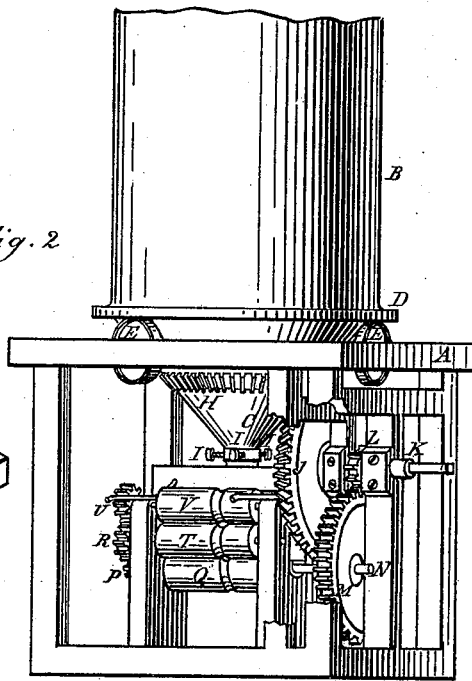

Fig. 2

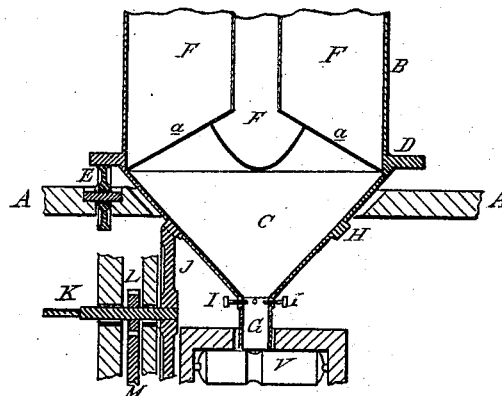

Fig. 3

Attest:
 A. Barthel
 H. Stanley.

Inventor
 G. Davis
 By Atty
 Thos. S. Sprague

UNITED STATES PATENT OFFICE.

GEORGE DAVIS, OF MILFORD, MICHIGAN.

IMPROVEMENT IN STRAW-BAND ATTACHMENTS FOR GRAIN-BINDERS.

Specification forming part of Letters Patent No. **212,200**, dated February 11, 1879; application filed July 17, 1878.

To all whom it may concern:

Be it known that I, GEORGE DAVIS, of Milford, in the county of Oakland and State of Michigan, have invented an Improvement in Straw-Band Attachments for Harvesters, of which the following is a specification:

The nature of my invention relates to certain new and useful improvements in devices designed to be attached to harvesters, which are provided with devices for binding the gavels or sheaves before being discharged from the harvester-table, so constructed as to spin or twist the straw bands as they may be required in the use of the harvester; and the invention consists in the novel construction and combination of the various parts, as more fully hereinafter described.

Figure 1 is a perspective view of my device, taken from the front. Fig. 2 is a rear elevation of the same. Fig. 3 is a vertical section through the center from side to side.

In the drawings, A represents a frame-work and table designed to support the operating parts of the device. B is a cylinder, terminating in an inverted cone, C, and is provided with a flange, D, which rests upon and rotates with friction-rollers E, suitably journaled at equal distances apart in the table-top of the frame A.

Within the cylinder B are secured the smaller cylinders F, their lower ends being beveled, as shown at *a*, and opening into the cone C, this being necessary to give more room within the cone to receive and handle the contents of the cylinders. This cone C projects downward through a suitable opening in the top of the frame A, and terminates in a short spinning-tube, G, through which, at equal distances apart, are adjustably inserted the spinning-teeth I. This adjustability may be secured in any desired manner which will allow the teeth to be projected within the tube G as much or as little as varying circumstances may require.

Secured to the outer face of the cone C are the teeth H, by means of which this part of the cone acts as a bevel or miter wheel engaging with the miter-wheel J, secured to the shaft K, by means of which and any suitable power the proper motion may be communicated to the cylinder B.

Upon this shaft K is also secured the pinion L, which engages with the geared wheel M, secured upon shaft N, in suitable bearings, and upon this shaft is also secured the drawing-roller O, the opposite end of the shaft being provided with a driving-pinion, P, which, engaging with the pinions Q R, gives motion to said pinions and to the drawing-rollers S T, which are suitably journaled in the frame for that purpose.

The pinion R engages with the pinion U and gives motion to the roller V, all said rollers and pinions being so arranged that O and S form one pair, and T and V form another, one of each pair only rotating in the same direction. Upon the same vertical line, and in line with the center of the spinning-tube, these rollers are grooved, as shown in the drawings, and for the purpose hereinafter described.

In practice the operation of this device is as follows: The small cylinders F are filled with straw, preferably the stubble end being presented downward, and a small quantity thereof forced downward through the spinning-tube, twisted by hand, and inserted through the grooves in the rollers T V, the former of which should have a slight vertical adjustability. This being done, motion should be given to the machine through the shaft K and the various gears connected therewith, and as hereinbefore described. This motion, by means of the teeth I, spins or twists the straw passing through the spinning-tube G, and the position of said teeth regulates the size of the band, as may be required, such band being drawn through the spinner by the operation of the rollers hereinbefore described, and a greater or lesser number of such rollers may be employed, as is necessary to perform the work.

If desired, the spaces between the small cylinders and between them and the cylinder B may also be filled with straw, and the number of the small cylinders may be increased or diminished from those shown in the drawings, so long as the spirit of this part of the invention, which is to preserve the straw in a straight and vertical position, is not departed from.

What I claim as my invention is—

1. In a device for making continuous straw bands, and in combination with a battery of cylinders, as described, the cone C, terminating in the spinning-tube G, the latter of which is provided with laterally-adjustable teeth I, substantially as and for the purposes set forth.
2. A machine for making straw bands, wherein are combined the cylinders B F, inverted cone C, spinning-tube G, with teeth I, and a system of drawing-rollers, constructed and arranged substantially as described and shown.

GEORGE DAVIS.

Witnesses:

H. S. SPRAGUE,
A. BARTHEL.